

DOI: <https://doi.org/10.33103/uot.ijccce.23.3.8>

Design of Ultra Dense WDM Optical Communication System to Reduce Signal Impairments Using DCF and Repeater Techniques

Dina S. Akram¹, Haydar M. AL-Tamimi²^{1,2}Department of Communication Engineering, University of Technology, Baghdad, Iraq
coe.21.02@grad.uotechnology.edu.iq¹, ²haydar.m.abdulahadi@uotechnology.edu.iq²

Abstract— Linear and non-linear impairments are the major problems that affected the dense wavelength division multiplexing (DWDM) system performance. In this simulation designs, two different compensation techniques have been proposed to eliminate signal impairments. The repeater technique was proposed to reduce non-linear effects like four-wave mixing (FWM) which cause transfer power from DWDM channels to another new channels. The dispersion compensation fiber (DCF) technique was used to reduce dispersion effects which cause signal pulse broadening over long transmission distances. Also, three different modulation formats and four frequency separations were used to determine which modulation scheme is more compatible with the compensation techniques. The results is calculated in term of quality factor against power and noetic that the carrier suppressed return to zero (CSRZ) format offers the best performance with the DCF technique with 32.1804 Q-factor at 15dBm threshold power then, the differential phase shift keying (DPSK) format is compatible with the repeater technique with 27.7959 quality factor and 14dBm threshold power.

Index Terms— Dense Wavelength Division Multiplexing (DWDM), Dispersion Compensation Fiber DCF, Repeater, and Non-linear Effects.

I. INTRODUCTION

Recently, optical communication systems have experienced massive growth in system capacity, transmission distance, and the number of users [1],[2]. The dense wavelength division multiplexing (DWDM) technique has been proposed for transmitting multiple optical signals over long distances and large bandwidth utilized with a narrow frequency separation between channels [3] [4]. The optical signal is degraded due to linear and non-linear effects. The linear impairment is classified as attenuation and dispersion. The signal is attenuated when the optical power is lost over a long transmission distance. Optical amplifiers were proposed for amplifying the distorted signal and processing the attenuation problems [5], [6]. The dispersion is caused by pulse broadening of the optical spectrum when the signals are transmitted over a long transmission distance at different speeds and this makes some signals arrive before others [7], [8]. The dispersion compensation fiber (DCF) is an essential technique to reduce the dispersion problem by inserting negative dispersion to make the mean value close to zero [9], [10]. The non-linear impairments are classified into two categorize the first is due to non-linear scattering effects such as stimulated Raman scattering (SRS) and stimulated Brillouin scattering (SBS) and the second is due to nonlinear refractive index which called the Kerr effects like four-wave mixing (FWM), self-phase modulation (SPM) and, cross-phase modulation (XPM) [11],[12]. There are different techniques were proposed to reduce non-linear problems like unequal channels spacing, the choice of modulation formats, and the repeater technique [13], [14].

DOI: <https://doi.org/10.33103/uot.ijccce.23.3.8>

In this paper, The Dense WDM technique was proposed with four channels spacing (25GHz, 50GHz, 100GHz, and 150GHz) and three different modulation formats (carrier suppressed return to zero (CSRZ), differential phase shift keying (DPSK), and intensity modulations) to reduce linear and nonlinear impairments using repeater and DCF techniques. Fig. 1 below shows the optical links proposed in the simulation designs.

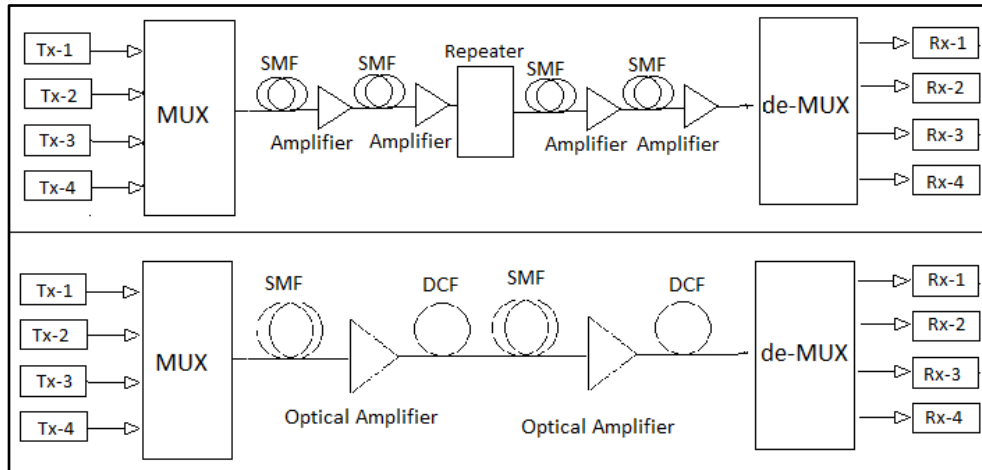

FIG. 1. BLOCK DIAGRAM OF NETWORK FRAME WORK USING REPEATER AND DCF TECHNIQUES.

II. SIMULATION SETUP

The simulation design uses optisystem15 for transmitting a 5Gbps bit rate over a 400Km distance. At the transmitter port, three different modulation formats (CSRZ, DPSK, and intensity modulations) were used for modulating the electrical signal with an optical pulse and directed to a 4:1 multiplexer for combining all optical channels. After that, the signal was directed to an optical path. There are two optical links proposed in the simulation design the first by using the DCF technique and the second by using the repeater technique.

A. Simulation design using the DCF technique

The signal is directed to the optical link which contains symmetric segments of optical fiber, optical amplifier, and DCF. The optical fiber with 25Km length and 0.2dB/Km attenuations directed to an optical amplifier with a 5dB gain. When the amplifier gain G is given by:

$$G = \frac{P_{out}}{P_{in}} \quad (1)$$

where P_{out} and P_{in} is output power and input power. Then, the signal was directed to the DCF with a 5Km length and $-83.75\text{ps.nm}^{-1}.\text{Km}^{-1}$ negative dispersion value to reduce the chromatic dispersion caused by propagation delay difference between spectral components. When the chromatic dispersion D_C of single mode fiber (SMF) is given by:

$$D_C = D_M + D_W \quad (2)$$

$$D_M = \frac{\lambda}{c} \left| \frac{d^2 n}{d\lambda^2} \right|$$

$$D_W = -\left(\frac{n_1 - n_2}{\lambda c}\right) V \frac{d^2 V b}{dV^2}$$

where D_M is material dispersion when $\frac{d^2 n}{d\lambda^2} \neq 0$, and D_W is waveguide dispersion when $\frac{d^2 \beta}{d\lambda^2} \neq 0$ and β is propagation constant, λ is wavelength, c is speed of light, n_1 and n_2 is core and cladding refractive index, V is normalized frequency for the SMF and b is

DOI: <https://doi.org/10.33103/uot.ijccce.23.3.8>

normalized propagation constant [15]. The negative dispersion value of DCF can calculate by:

$$D_{DCF} = -\frac{D_{SMF}L_{SMF}}{L_{DCF}} \quad (3)$$

where L_{SMF} and L_{DCF} is the length of SMF and DCF[16], [17] The descriptions of the main parameters value of the DCF simulation design are proposed in the Table I.

TABLE I. THE MAIN PARAMETER OF DCF SIMULATION DESIGN

Parameters	Values
Bit Rate	5Gbit/s
WDM	Number of Channels: 4 Channels
SMF	Length: 400Km Attenuation:0.2dB/Km Dispersion: 16.75ps/nm/Km Dispersion Slope: 0.075ps/nm ² /Km
DCF	Length: 5Km Attenuation: 0.2dB/Km Dispersion: -83.75ps/nm/km DispersionSlope: 16.75ps/nm ² /Km
Optical Amplifier	Gain: 5dB Noise Figure: 4dB

Fig. 2, shows the simulation design of CSRZ modulation formats with 4 DWDM channels using DCF technique.

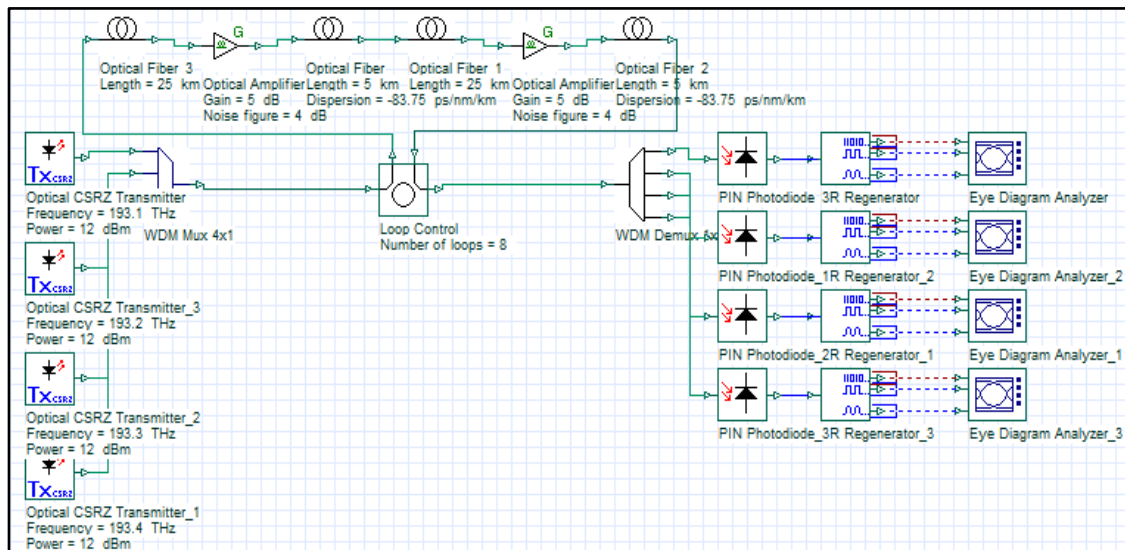

FIG. 2. BLOCK DIAGRAM OF CSRZ MODULATION FORMATS USING DCF TECHNIQUE.

B. Simulation design using the repeater technique

At the repeater technique, the optical path consists of four symmetric segments of SMF and an optical amplifier with a repeater in the middle. The signal is directed to an optical fiber with 100Km length and 0.2dB/Km attenuation and then, switched to the amplifier with 20dB gain. After that, the repeater is converted the optical signal to an electrical signal for processing and retransmitting through the optical path. Table II, below was describes the main parameters value of the repeater simulation design.

DOI: <https://doi.org/10.33103/uot.ijccce.23.3.8>

TABLE II. THE MAIN PARAMETER OF REPEATER SIMULATION DESIGN

Parameters	Values
Bit Rate	5Gbit/s
WDM	Number of Channels: 4 Channels
SMF	Length: 400Km Attenuation:0.2dB/Km Dispersion: 16.75ps/nm/Km Dispersion Slope: 0.075ps/nm ² /Km
Repeater	Modulation Format: NRZ Power: Variable
Optical Amplifier	Gain: 20dB Noise Figure: 4dB

Fig. 3, and Fig. 4 below describe the simulation design of the repeater technique with DPSK modulation format.

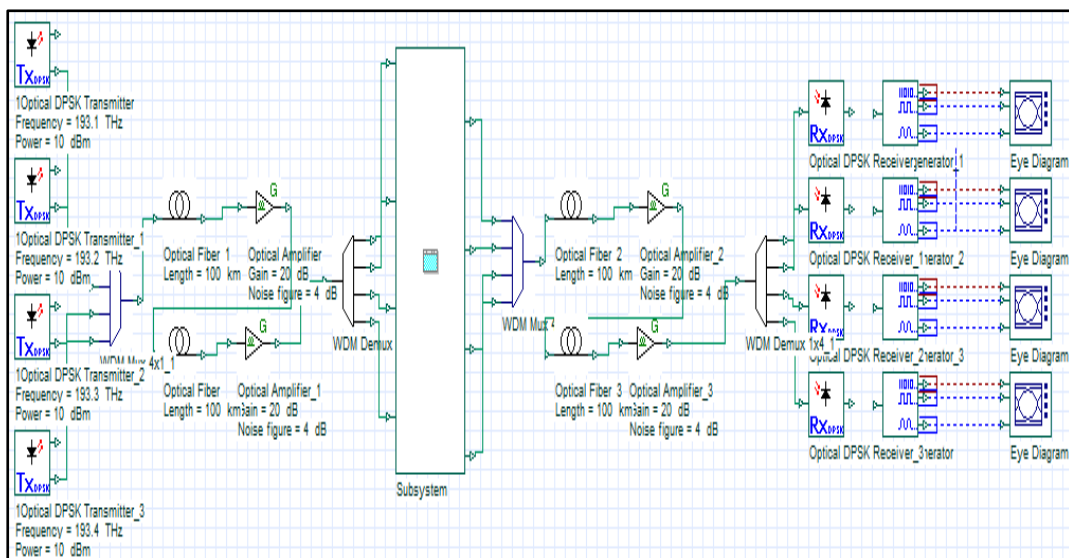

FIG. 3. BLOCK DIAGRAM OF DPSK MODULATION FORMATS USING REPEATER TECHNIQUE.

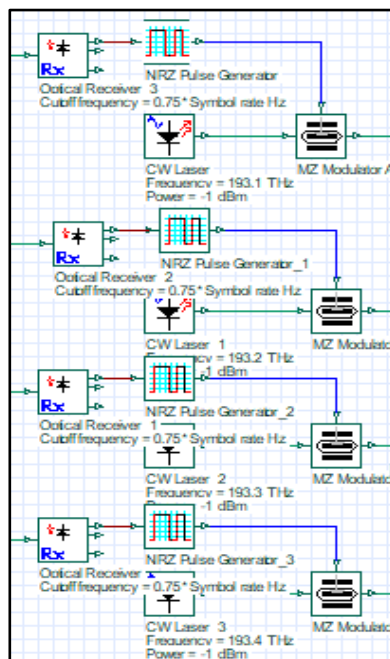

FIG. 4. MODULATION FORMAT OF REPEATER TECHNIQUE.

DOI: <https://doi.org/10.33103/uot.ijccce.23.3.8>

At the receiver port, the demultiplexer distributes the optical signal between 4 channels every channel accepts a specific wavelength and then, is directed to an optical receiver for conversion optical signal to an electrical pulse. There are two types of optical receivers proposed in these designs according to compatibility with modulation formats. The first is the DPSK receiver was proposed for receiving the DPSK transmitter signal, and the second is the PIN photodiode was proposed for receiving the signal of CSRZ and intensity modulation formats. Finally, the signal is directed to the 3R-regenerator and eye diagram analyzer for calculating the quality factor of the signal at the range value of input power.

III. RESULTS AND DISCUSSION

Two transmission techniques were proposed for transmitting data over 400Km distance with 4 channels DWDM and three different modulation formats (CSRZ, DPSK, and, intensity modulations) to evaluate the system's performance in terms of quality factor versus power. The DCF is an essential technique to reduce dispersion effects especially, chromatic dispersion (CD) by using optical fiber with a negative dispersion value. The DCF length and position play a key role in overcoming dispersion problems. A small amount of dispersion is required to reduce non-linear effects especially, the FWM effect [18]. The repeater technique was proposed to minimize the non-linear effects like FWM as much as possible by retransmitting the optical signal with a range of optical power values [19], [20].

A. The results of the DCF technique

Table III shows the maximum Q-factor for 4 DWDM channels with three different modulation formats and variable channels spacing (150, 100, 50, and 25GHz) using the DCF technique.

TABLE III. MAXIMUM QUALITY FACTOR VALUE OF DWDM USING DCF TECHNIQUE

Channels Spacing	CSRZ	Intensity Modulation	DPSK
150GHz	27.795	21.486	10.042
100GHz	22.407	17.721	9.7593
50GHz	19.017	12.238	9.2638
25GHz	32.180	7.8885	5.3629

Fig. 5, below shows the performance evaluation of 4 DWDM channels using CSRZ, NRZ-DPSK, and RZ-intensity modulations with 150GHz channel spacing in a term of quality factor versus power. The quality factor reaches the maximum point at a specific power value called threshold power. After that, the quality factor decreases with power due to non-linear effects. From this figure, the return to zero (RZ) modulation formats offer the best performance compared with the non-return to zero (NRZ) formats because the RZ operates at large input power, small intersymbol interference, and high sensitivity. For 4-WDM channels, CSRZ has the best performance with 27.795 Q-factor at 14dBm power this is because the CSRZ is not affected by non-linear impairments and operates at high threshold power which supports the increased distance between transmitter and receiver. For intensity modulation, the Q-factor value is 21.486 at 13dBm power, and the lowest value at DPSK modulation with 10.042 quality factor at 12dBm power this is because the NRZ-DPSK modulation format has affected by signal non-linear effects especially, non-linear phase noise. The DPSK performance degrades with increasing distance between transmitter and receiver.

DOI: <https://doi.org/10.33103/uot.ijccce.23.3.8>

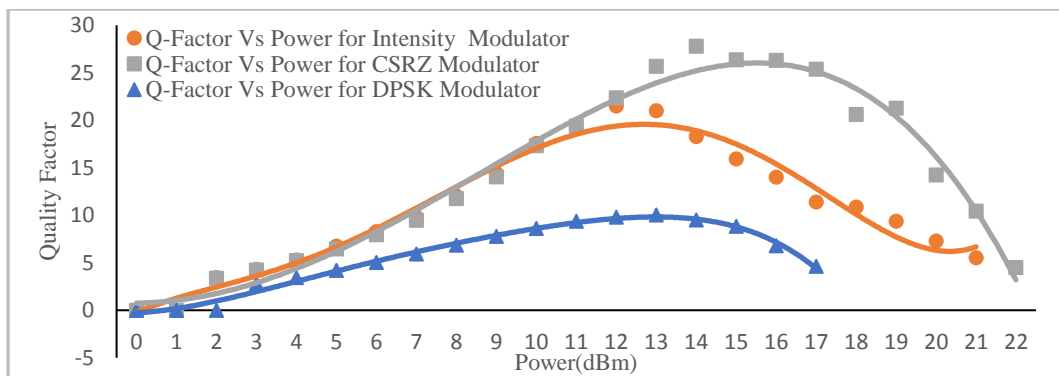

FIG. 5. Q-FACTOR VERSUS INPUT POWER FOR DIFFERENT MODULATION TYPE USING 150GHZ CHANNEL SPACING.

Fig. 6, shows the performance analysis of three modulation formats with 100GHz channels spacing. The system capacity and bandwidth utilization increase with reduced frequency separation between channels. The CSRZ corresponds with reducing channels spacing because it improved dispersion tolerance and minimized the non-linear effect by reducing spectral width [21]. The CSRZ offers the maximum value with 22.407 Q-factor at 15dBm, then the intensity modulation with 17.721 at 13dBm power, and the DPSK format has a lower value with 9.7593 at 12dBm power.

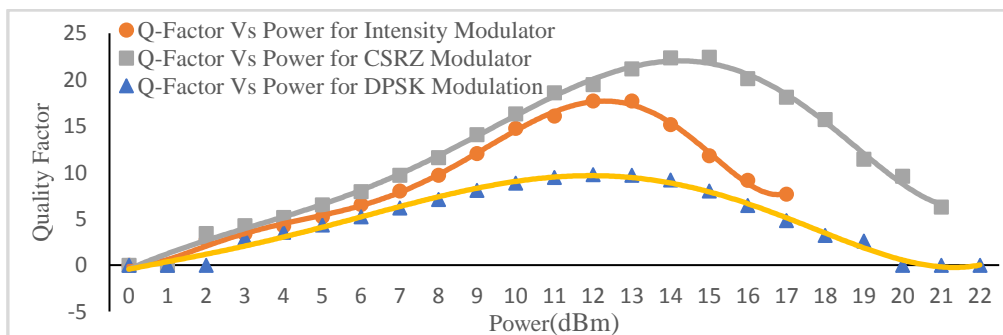

FIG. 6. Q-FACTOR VERSUS INPUT POWER FOR DIFFERENT MODULATION TYPE USING 100GHZ CHANNEL SPACING.

Fig. 7, describes the DWDM performance at 50GHz channels spacing. There are many advantages to reducing the separation between channels such as capacity increase, large bandwidth utilized, and saving cost. Although, system performance is degraded by reducing channels spacing due to interference between multiple optical signals. For the 4-DWDM simulation design, the CSRZ format has the best value of 19.017 Q-factor at 16dBm Q-factor then the intensity modulation with 12.238 Q-factor at 11dBm power, and the DPSK modulation has the worst performance with 9.2638 Q-factor at 9dBm power.

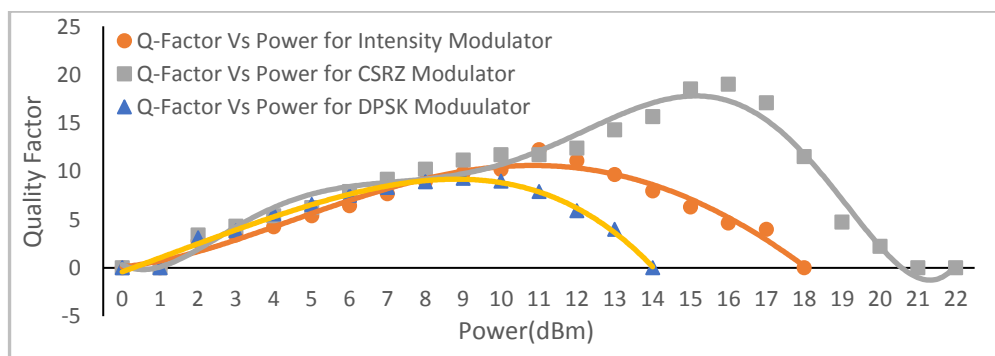

FIG. 7. Q-FACTOR VERSUS INPUT POWER FOR DIFFERENT MODULATION TYPE USING 50GHZ CHANNEL SPACING.

DOI: <https://doi.org/10.33103/uot.ijccce.23.3.8>

At Fig. 8, we reduced the separation between channels to 25GHz for three different modulation formats. In these designs, the CSRZ offers superior performance because CSRZ is compatible with the narrow optical spectrum and offers the best tolerance for chromatic dispersion, and minimizes the FWM effects. For 4-DWDM channels, CSRZ comes in the first level with 32.81 Q-factor with a high threshold power 17dBm then the intensity modulation with 7.8885 quality factor and 8dBm power. The DPSK format comes in last with a 5.3629 Q-factor and 8dBm threshold power. From these threshold power values find that the CSRZ format is compatible with increased power to a high level which leads to an increase in the distance between transmitter and receiver.

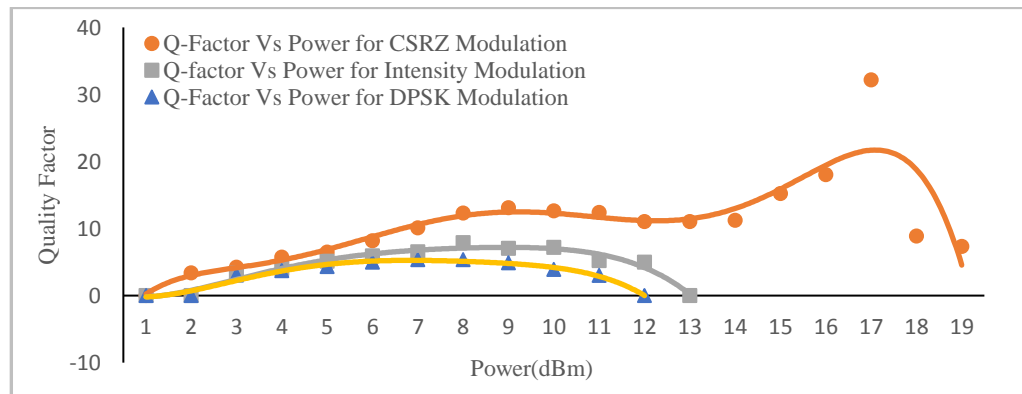

FIG. 8. Q-FACTOR VERSUS INPUT POWER FOR DIFFERENT MODULATION TYPE USING 25GHZ CHANNEL SPACING.

When a comparison between different frequency separations. I believe the 25GHz channels spacing offers maximum bandwidth utilization and high Q-factor with large threshold power for CSRZ format. However, it provides a small Q-factor with low threshold power for DPSK and intensity modulations. The 50GHz frequency separation provides high bandwidth utilization with the capacity upgrade but it has some drawbacks like interference between optical signals and non-linear effects. The 100GHz channel spacing provides acceptable performance for both CSRZ and intensity modulations. The 150GHz spacing has a maximum quality factor and large threshold power but, it experiences bandwidth loss between channels and small system capacity.

Table IV, provides a comparison between this simulation design and other previous designs for 4 DWDM channels and the DCF technique in terms of transmission length, modulation formats, and system performance.

TABLE IV. COMPARISON BETWEEN SIMULATION DESIGN WITH PREVIOUS DESIGNS USING DCF TECHNIQUE

Parameters	Our Design	Meena and Pramod Design [4]	Meena and Deepika Design [22]
Modulation Formats	CSRZ, DPSK, and Intensity Modulation	RZ and NRZ formats	RZ, NRZ, and Gaussian
Channels Spacing	150, 100, 50, 25GHz	100GHz	100GHz
Channels Number	4	4	4
Fiber Length	400Km	150Km	150Km
Bit Rate	5Gbps	10Gbps	8Gbps
Quality Factor	32.18 with CSRZ Format 21.18 with Intensity Modulation 10 with DPSK Format	9.16 with NRZ Format 16.3 with RZ Format	10.77 with NRZ Format 33.7 with RZ Format 21.12 with Gaussian

DOI: <https://doi.org/10.33103/uot.ijccce.23.3.8>

B. The results of repeater technique

The repeater and DCF techniques were proposed for transmitting 4 DWDM channels at three different modulation formats and four different channels spacing. *Fig. 9* below shows that the repeater technique offers a special performance for the DPSK modulation format with 20.7913 quality factor and 14dBm power this is because the repeater technique was proposed to reduce non-linear effects like non-linear phase noise of DPSK formats. The DCF has ten order lower performance than the repeater technique with a 10.0425 quality factor and 15dBm power.

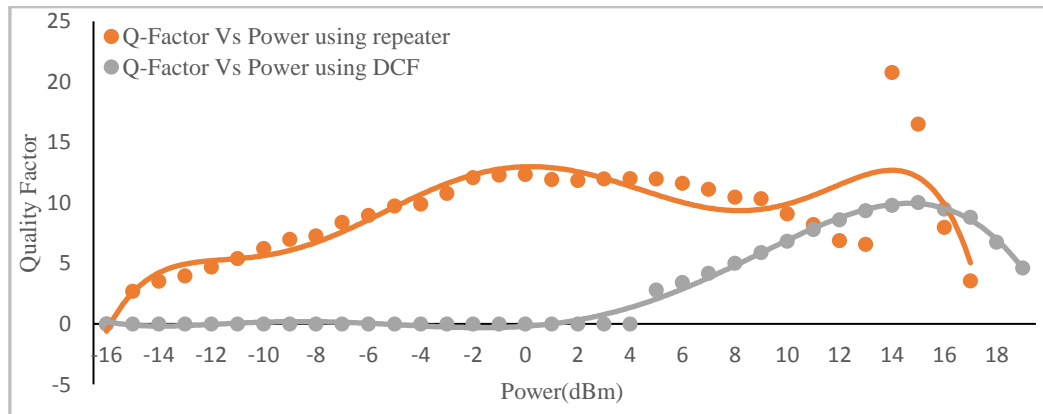

FIG. 9. PERFORMANCE ANALYSIS OF DPSK MODULATION WITH 150GHZ CHANNEL SPACING USING REPEATER AND DCF TECHNIQUES.

Fig. 10, shows the performance of CSRZ modulation formats with 150GHz channel spacing. For 4 channels, the DCF offer a best performance with 27.7959 quality factor at 14dBm power. The high-quality factor of DCF because there are 16 segments of DCF were used in system design. then the repeater offers a worst performance with 11.9095 quality factor and low (3dBm) threshold power. The poor performance of repeater technique is due to use only on repeater on the system design.

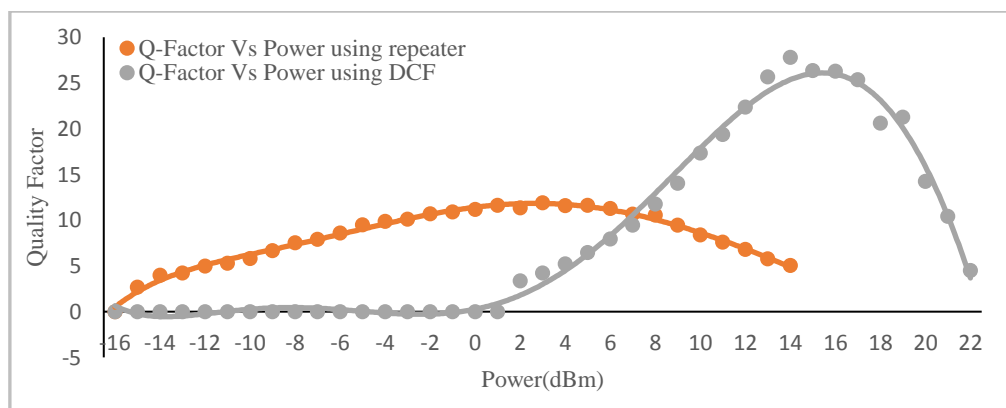

FIG. 10. PERFORMANCE ANALYSIS OF CSRZ MODULATION WITH 150GHZ CHANNEL SPACING USING REPEATER AND DCF TECHNIQUES.

Fig. 11, describes the performance of the intensity modulation format at 150GHz spacing. For simulation design, the DCF Q-factor was higher by 9 orders than the repeater with 21.4862 Q-factor for DCF at 14dBm power and 12.5623 for the repeater at 4dBm power. Although, the repeater technique operates over a wide range of optical power.

DOI: <https://doi.org/10.33103/uot.ijccce.23.3.8>

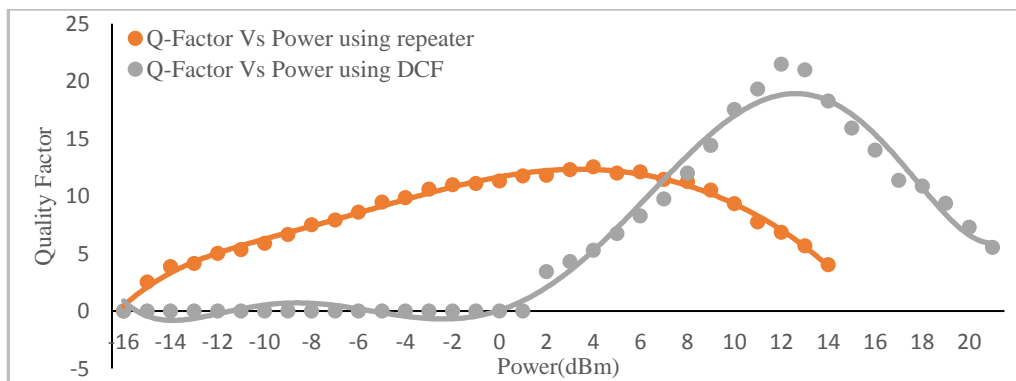

FIG. 11. PERFORMANCE ANALYSIS OF INTENSITY MODULATION WITH 150GHZ CHANNEL SPACING USING REPEATER AND DCF TECHNIQUES.

Fig. 12, shows the DPSK performance with reducing channels spacing to 100GHz. When a comparison between DCF and repeater performance we found the repeater technique has a 20.6517 quality factor at 12 dBm power then, the DCF has a low value of Q-factor (8.455), and the DCF power increase by two orders than the repeater technique. The NRZ-DPSK has a low-quality factor with the DCF technique because it affects by non-linear impairments.

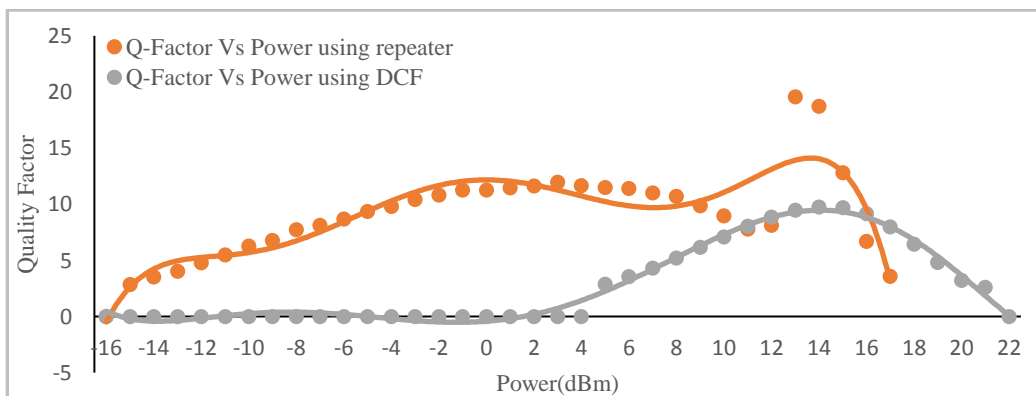

FIG. 12. PERFORMANCE ANALYSIS OF DPSK WITH 100GHZ CHANNEL SPACING USING REPEATER AND DCF TECHNIQUES.

The performance of the CSRZ modulation format was described in Fig. 13 with 100GHz channels spacing. The DCF has the best performance with a 22.4074 quality factor at 15dBm power then the repeater has the worst performance because only one repeater is used in the simulation design. The repeater has a 12.1323 quality factor with a threshold power low by 12 orders than the repeater technique.

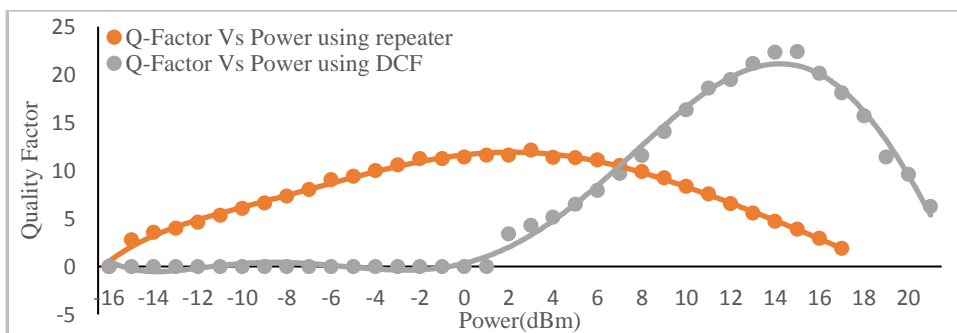

FIG. 13. PERFORMANCE ANALYSIS OF CSRZ WITH 100GHZ CHANNEL SPACING USING REPEATER AND DCF TECHNIQUES.

DOI: <https://doi.org/10.33103/uot.ijccce.23.3.8>

At Fig. 14, we describe the performance of intensity modulation at 100GHz frequency separation. For 4 channels the 17.721 quality factor of the DCF technique has a 5 orders higher value than the quality factor of the repeater when the threshold power of a DCF is 10dBm and 2dBm for the repeater.

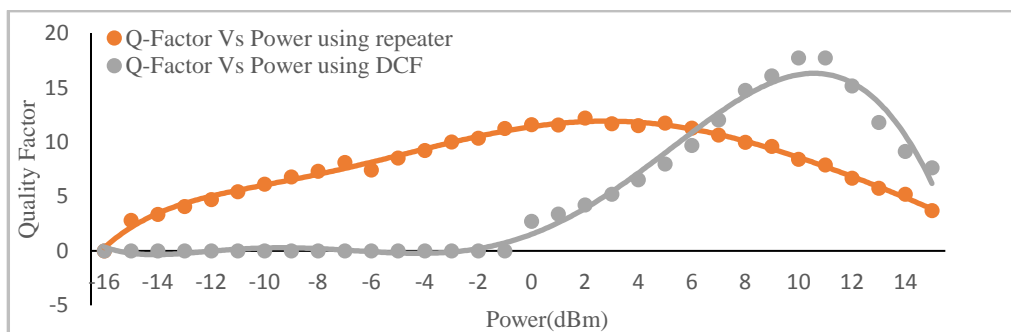

FIG. 14. PERFORMANCE ANALYSIS OF INTENSITY MODULATION WITH 100GHZ CHANNEL SPACING USING REPEATER AND DCF TECHNIQUES.

Fig. 15, describes the performance of DPSK formats at 50GHz spacing. After comparison between repeater and DCF technique in a term of quality factor against power we found that the repeater has large quality factor (11.7283) at 0dBm threshold power compare with DCF Q-factor (9.26388) at 12dBm threshold power. Typically, At DPSK modulation the Q-factor of repeater is higher than the DCF Q-factor because of that the repeater was used for minimize the non-linear phase noise caused by DPSK formats.

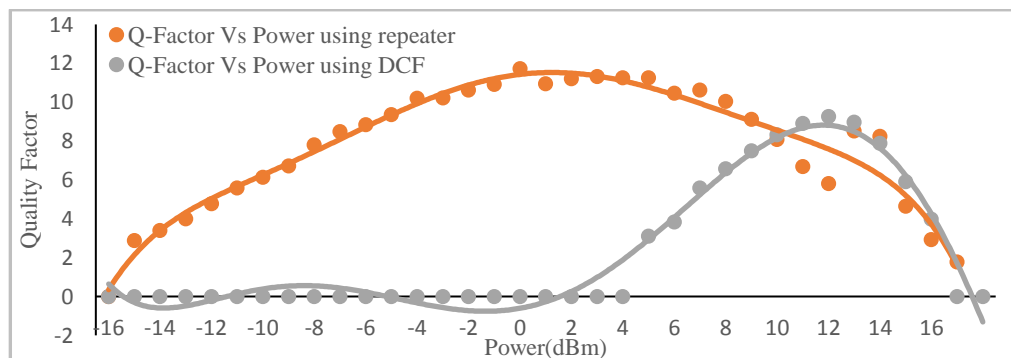

FIG. 15. PERFORMANCE ANALYSIS OF DPSK MODULATION WITH 50GHZ CHANNEL SPACING USING REPEATER AND DCF TECHNIQUES.

Fig. 16, shows the CSRZ performance with 4 DWDM channels and 50GHz frequency separation. The DCF has a 19.0171 quality factor when the DCF operates at a high threshold power 16dBm and small non-linear effects then, the repeater has an 11.4572 Q-factor at 4dBm power.

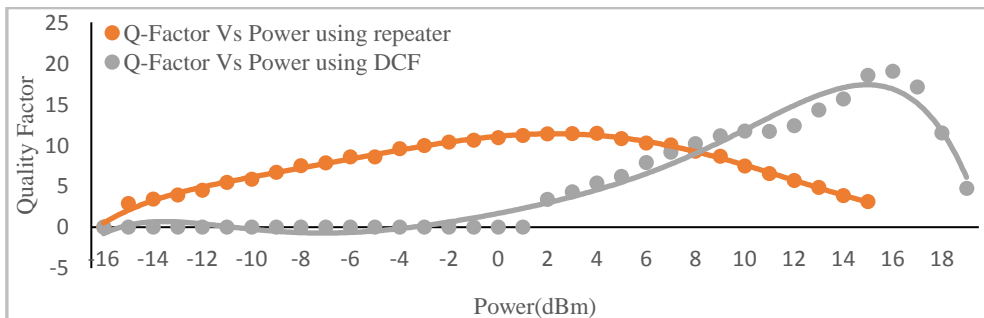

FIG. 16. PERFORMANCE ANALYSIS OF CSRZ MODULATION WITH 50GHZ CHANNEL SPACING USING REPEATER AND DCF TECHNIQUES.

DOI: <https://doi.org/10.33103/uot.ijccce.23.3.8>

At Fig. 17, we describe the performance of intensity modulation. The repeater and DCF techniques have the same quality factor (12) but at different threshold power (2dBm for the repeater and 9dBm for the DCF technique). The DCF has the best performance because it operates at high threshold power and makes it compatible with long transmission distances.

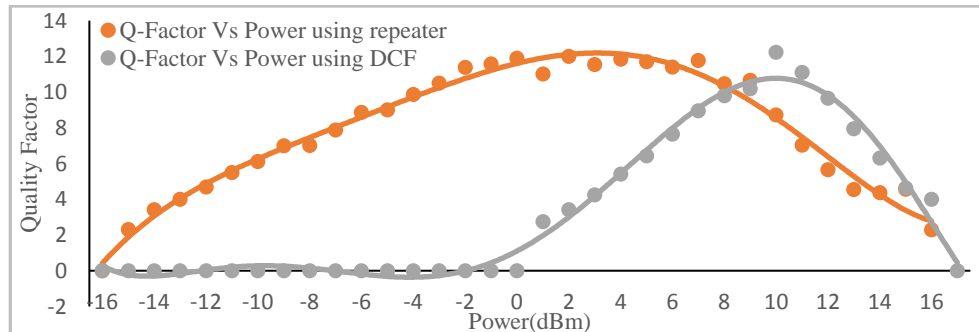

FIG. 17. PERFORMANCE ANALYSIS OF INTENSITY MODULATION WITH 50GHZ CHANNEL SPACING USING REPEATER AND DCF TECHNIQUES.

Fig. 18, shows the performance of the DPSK modulation format with reducing channel spacing to 25GHz. The repeater technique has a 7.80234 Q-factor value at 3dBm power then, the maximum Q-factor value of the DCF technique has 5.36295 at 9dBm power. These values show the DCF has a low Q-factor value but high threshold power by 6 orders than the repeater technique.

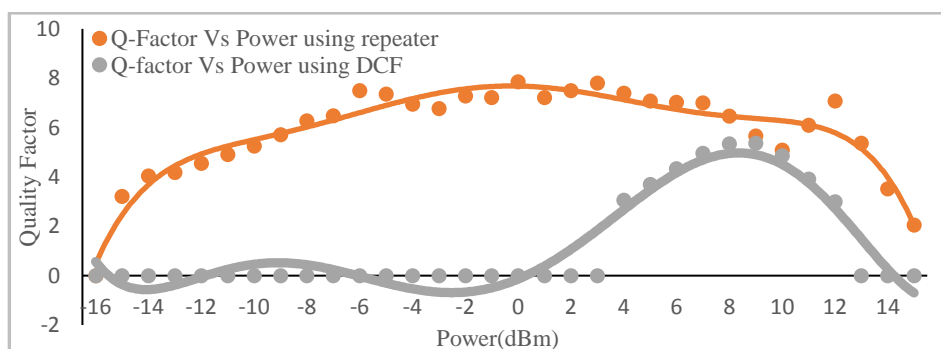

FIG. 18. PERFORMANCE ANALYSIS OF DPSK MODULATION WITH 25GHZ CHANNEL SPACING USING REPEATER AND DCF TECHNIQUES.

Fig. 19, proposes the CSRZ performance at 25GHz channels spacing using DCF and repeater. At 25GHZ the CSRZ offers superior performance with 32.1804 Q-factor at 15dBm power this is because the CSRZ is compatible with narrow optical spectrum then, the repeater technique has 8.6454 Q-Factor at low threshold power (-4dBm).

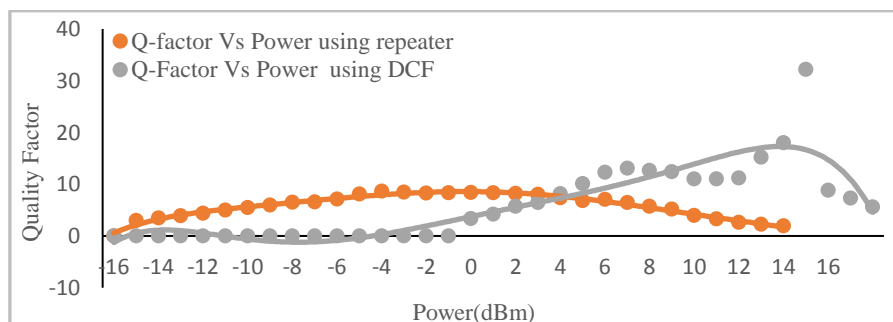

FIG. 19. PERFORMANCE ANALYSIS OF CSRZ MODULATION WITH 25GHZ CHANNEL SPACING USING REPEATER AND DCF TECHNIQUES.

DOI: <https://doi.org/10.33103/uot.ijccce.23.3.8>

At Fig. 20, we describe the performance of intensity modulation with 25GHz spacing. The maximum threshold power degrades with reduced separations between channels. For this design, the repeater has a 10.0383 Q-factor for -2dBm power, and the DCF has a 7.8885 Q-factor at 7dBm power.

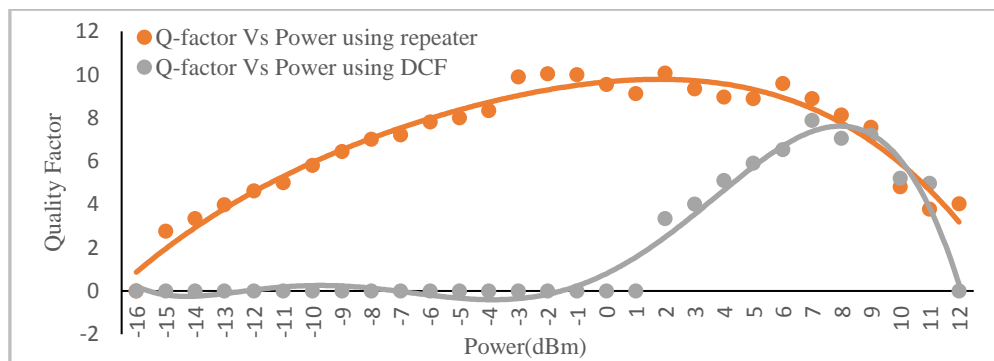

FIG. 20. PERFORMANCE ANALYSIS OF INTENSITY MODULATION WITH 25GHz CHANNEL SPACING USING REPEATER AND DCF TECHNIQUES.

When a comparison between multiple systems designs, I believe that the DPSK modulation formats are compatible with the repeater technique because the repeater technique was proposed to reduce the non-linear effects of the NRZ-DPSK format. The CSRZ formats offer maximum performance with the DCF technique and compatible with reducing frequency separation to 25GHz because the CSRZ improves the dispersion tolerance. The intensity modulation provides an acceptable performance with DCF and repeater techniques.

Table V below provides a comparison between this simulation design and the previous design for 4 DWDM channels and the repeater technique in terms of transmission length, modulation formats, and system performance.

TABLE V. COMPARISON BETWEEN SIMULATION DESIGN WITH PREVIOUS DESIGNS USING REPEATER TECHNIQUE

Parameters	Our Design	Yasseen, Saif. and Hayder design [13]
Modulation Formats	CSRZ, DPSK, and Intensity Modulation	NRZ formats
Channels Spacing	150, 100, 50, 25GHz	Unequal Spacing
Channels Number	4	8
Fiber Length	400Km	300Km
Bit Rate	5Gbps	2Gbps
Quality Factor	20.79 with 150GHz Spacing 20.65 with 100GHz Spacing 11.72 with 50GHz Spacing 7.80 with 25GHz Spacing	35 with Unequal Spacing

IV. CONCLUSIONS

The 4-DWDM system was proposed at three different modulation formats (CSRZ, DPSK, and Intensity modulations) and four different channels spacing (150, 100, 50, 25GHz) for transmitting 5Gbps over 400Km distance. Also, there are two optical links were used for reducing different linear and non-linear impairments. The repeater technique was used to reduce non-linear problems especially, FWM. The DPSK modulation format has the best performance when using the repeater technique with a 27.7959 quality factor and 14dBm threshold power. The DCF proposed to reduce dispersion problems

DOI: <https://doi.org/10.33103/uot.ijccce.23.3.8>

especially, chromatic dispersion. The CSRZ modulation format has the best performance at 25GHz channels spacing with 32.1804 Q-factor and 15dBm threshold power.

Declaration. The researchers report that no means, grants, or other support were received while preparing this article. The researchers have no financial or non-financial interest to proclaim. All researchers have read and agreed to the final article. The datasets and curves created during the existing study are available from the corresponding researcher upon reasonable request. Competing interests. The researchers have not exposed any competing interests.

REFERENCES

- [1] F. Ali, F. Muhammad, U. Habib, Y. Khan, and M. Usman, "Modeling and minimization of FWM effects in DWDM-based long-haul optical communication systems," *Photonic Network Communications*, vol. 41, no. 1, pp. 36–46, Feb. 2021, doi: 10.1007/s11107-020-00913-9.
- [2] H. Hassan, M. A. Munshid, and A. AL-Janabi, "Four-wave-mixing assisted multi-wavelength short pulse generation in an erbium-doped-fiber laser based tellurium nanorod saturable absorber," *Photonics Nanostruct*, vol. 43, Feb. 2021, doi: 10.1016/j.photonics.2020.100884.
- [3] M. H. Ali, A. K. Abass, and S. A. Abd Al-Hussein, "32 Channel \times 40 Gb/s WDM optical communication system utilizing different configurations of hybrid fiber amplifier," *Opt Quantum Electron*, vol. 51, no. 6, Jun. 2019, doi: 10.1007/s11082-019-1842-8.
- [4] M. Vikas Dikoliya and P. Sharma, "PERFORMANCE EVALUATION OF DWDM OPTICAL TRANSFORMATION SYSTEM USING DIFFERENT MODULATION FORMATS," 1258. [Online]. Available: www.irjmets.com
- [5] A. K. Abass, M. H. Ali, and S. A. A. Al-Hussein, "Optimization of Hybrid Fiber Amplifier Utilizing Combined Serial-Parallel Configuration," in *IOP Conference Series: Materials Science and Engineering*, Dec. 2018, vol. 454, no. 1. doi: 10.1088/1757-899X/454/1/012014.
- [6] A. A. Almkhtar, A. K. Abass, and M. H. Ali, "Optimization and Performance Evaluation of C+L Band Wavelength Division Multiplexing Based on Free Space Optical Communication," in *Journal of Physics: Conference Series*, Mar. 2021, vol. 1795, no. 1. doi: 10.1088/1742-6596/1795/1/012069.
- [7] S. Salam Radhi, J. K. Hmood, and S. W. Harun, "Performance analysis of WDM-SDM system with employing Phase-Conjugated twin waves technique," in *Materials Today: Proceedings*, 2021, vol. 42, pp. 2490–2496. doi: 10.1016/j.matpr.2020.12.568.
- [8] M. M. Abbood *et al.*, "Dispersion compression for different optic communication systems using DCF and FBG," in *AIP Conference Proceedings*, Oct. 2021, vol. 2404. doi: 10.1063/5.0070871.
- [9] S. R. Tahhan, M. H. Ali, and A. K. Abass, "Characteristics of Dispersion Compensation for 32 Channels at 40 Gb/s under Different Techniques," *Journal of Optical Communications*, vol. 41, no. 1, pp. 57–65, Jan. 2020, doi: 10.1515/joc-2017-0121.
- [10] M. L. Meena and R. Kumar Gupta, "Design and comparative performance evaluation of chirped FBG dispersion compensation with DCF technique for DWDM optical transmission systems," *Optik (Stuttg)*, vol. 188, pp. 212–224, Jul. 2019, doi: 10.1016/j.ijleo.2019.05.056.
- [11] J. M. Senior, "Optical Fiber Communications Principles and Practice Third Edition Optical Fiber Communications Principles and Practice Third Edition." [Online]. Available: www.pearson-books.com
- [12] H. R. Suresh, V. Vinitha, N. Girinath, and R. Karthick, "Suppression of four wave mixing effect in DWDM system," in *Materials Today: Proceedings*, 2021, vol. 45, pp. 2707–2712. doi: 10.1016/j.matpr.2020.11.545.
- [13] S. H. Abdulwahed, H. F. Abdulsada, Y. Sadoon Atiya, S. Hussam Abdulwahed, and H. Fadhil Abdulsada, "Compensation of 8x2 Bpbs Optic Non-Linear Effects using DCF and Repeater," 2019. [Online]. Available: <https://www.researchgate.net/publication/337440530>
- [14] I. S. Amiri *et al.*, "Optical communication transmission systems improvement based on chromatic and polarization Mode dispersion compensation simulation management," *Optik (Stuttg)*, vol. 207, Apr. 2020, doi: 10.1016/j.ijleo.2019.163853.
- [15] A. Gharat, P. Nawale, P. Waje, B. Borse, and D. Patel, "Performance Analysis of CFBG and DCF Based on Dispersion Compensation," in *2020 IEEE International Students' Conference on Electrical, Electronics and Computer Science, SCEECS 2020*, Feb. 2020. doi: 10.1109/SCEECS48394.2020.170.

DOI: <https://doi.org/10.33103/uot.ijccce.23.3.8>

- [16] Md. B. Hossain, A. Adhikary, and T. Z. Khan, "Performance Investigation of Different Dispersion Compensation Methods in Optical Fiber Communication," *Asian Journal of Research in Computer Science*, pp. 36–44, Apr. 2020, doi: 10.9734/ajrcos/2020/v5i230133.
- [17] R. Thummar, D. Dhadhal, and V. Mishra, "Performance Analysis of 64 Channel DWDM System Using Single Mode Fiber at Different Power Levels and Frequency Spacing," in *Journal of Physics: Conference Series*, Mar. 2021, vol. 1804, no. 1. doi: 10.1088/1742-6596/1804/1/012153.
- [18] Hamed, Esraa K., Mohammed A. Munshid, and Jassim K. Hmood. "Performance analysis of mode division multiplexing system in presence of nonlinear phase noise." *Optical Fiber Technology* 57 (2020): 102230.
- [19] A. Adhikary, M. B. Hossain, T. Zaman Khan, S. J. Soheli, and M. A. Rahman Khan, "Performance analysis of Q-factor on wavelengths and bit rates using optical solitons with dispersion management," *Journal of Optics (India)*, vol. 49, no. 4, pp. 533–542, Dec. 2020, doi: 10.1007/s12596-020-00646-y.
- [20] F. Ali, Y. Khan, and S. Shafique Qureshi, "Transmission Performance Comparison of 16*100 Gbps Dense Wavelength Division Multiplexed Long Haul Optical Networks at Different Advance Modulation Formats under the Influence of Nonlinear Impairments," *Journal of Optical Communications*, vol. 43, no. 1, pp. 63–72, Jan. 2022, doi: 10.1515/joc-2018-0185.
- [21] D. Akram and H. M. AL-Tamimi, "Design of DWDM Optical Communication Systems with Different Modulation Formats Using DCF and Repeater," *Appl Opt*, Nov. 2022, doi: 10.1364/AO.480016.
- [22] M. L. Meena and D. Meena, "PERFORMANCE ANALYSIS OF DWDM OPTICAL NETWORK WITH DISPERSION COMPENSATION TECHNIQUES FOR 4×8 GBPS TRANSMISSION SYSTEM," *ONLINE) ICTACT JOURNAL ON MICROELECTRONICS*, pp. 2395–1680, 2018, doi: 10.21917/ijme.2018.0106.