



Contents lists available at <http://qu.edu.iq>

Al-Qadisiyah Journal for Engineering Sciences

Journal homepage: <https://qjes.qu.edu.iq>



Improved performance of hybrid optical communications system

Hassan Hamed Naji

Electronics and Communications Engineering Department, College of Engineering, University of Al-Qadisiyah, Iraq

ARTICLE INFO

Article history:

Received 10 August 2021

Received in revised form 25 October 2021

Accepted 05 December 2021

Keywords:

WDM

DWDM

MIMO

SISO

FSO

ABSTRACT

Frees Space Optical (FSO) system employs space to transfer information between the transmitter and receiver using light. However, the single-beam Single Input Single Output (SISO) technology is well known for being subject to air attenuation induced by weather conditions, which decreases the performance link range and data quality. The proposed system in this research combines DWDM and MIMO approaches to address this issue. The research is based on Opti system simulations with various weather reductions in many FSO systems: the FSO-DWDM-SISO (FDS) scheme and the suggested FSO-Hybrid-DWDM-MIMO method (FHDM). FHDM technology has considerably enhanced connection distance, received power, scalability, and data speed. At a data rate of 500 Mb/s, an evaluation is made between the suggested method and the FDS concerning quality factors during varied weather reduction using different numbers of optical transmission beams. The results show that the FHDM system improves connection distance, received optical power, minimum bit error rate (BER), and highest quality factor significantly during various weather conditions.

© 2021 University of Al-Qadisiyah. All rights reserved.

1. Introduction

FSO schemes appeared as a technological revolution in wireless schemes. This sort of scheme transmits data fast, making it an ideal method of communication in recent years, and it relies on light for transmission [1]. It offers numerous advantages over RF communication systems, including a large bandwidth mainly employed in mobile communication [2]. The RF communication technology has several disadvantages, including the need for time to get a spectrum frequency license and less security than optical communication [2, 3]. FSO frequencies operate in the near-infrared IR range, indicating that a line of sight FSO system offers a viable explanation to the last-mile problem in various circumstances, with the bonus of elasticity and high data rates. A broadband system FSO sends a modified beam of perceptible or infrared-

light over the sky [3]. In wireless systems, FSO has the potential for improvements and optimization in channel usability and economics [4-6]. The notion of FSO, or modulated light information, is not a new technology; it has been studied for a long time but has yet to be put into practice due to the limits of the electronic devices available at the time [6, 7]. Several issues have hampered the performance of the (FSO) system, the most significant of which being atmospheric attenuation. Weather conditions like fog, rain, and snow are the primary causes of signal absorption and scattering [8, 9], [12-14]. As a result, we can mitigate these issues by lengthening the transmission path and improving the received signal quality [10, 11], [14, 15]. The performance of transmission link FSO systems that use a single-beam between transmitter and receiver

* Corresponding author.

E-mail address: hassan.naji@qu.edu.iq (Hassan Naji)

<https://doi.org/10.30772/qjes.v14i4.800>

2411-7773/© 2021 University of Al-Qadisiyah. All rights reserved.



This work is licensed under a Creative Commons Attribution 4.0 International License.

stations (SISO) technique is poor; to improve the link performance of the system, multiple beams between transmit and receiving stations can be used Multiple-Input Multiple-Output (MIMO) technique [6, 7] [12]. By employing laser beam mixture expertise in a multi-beam FSO method, problems caused by weather attenuations scattering, absorption, and losses in received power due to detector losses can be mitigated [8], [15, 16]. Multi-beam (MIMO) technology eliminates transmission path interruptions caused by obstacles such as birds, insects, and weather attenuation such as fog, rain, snow, and scintillation. For example, low visibility occurs in coastal regions due to coastal fog, and the ideal solution is to use multi-beam (MIMO) to maintain perfect transmission path availability [10], [12]. MIMO replaces a single-beam transceiver with a multiple-beam transceiver in transmitter and receiver stations. Multiple channels with various attenuations can be obtained by changing this.

The earlier articles' weaknesses were that they did not account for the expanding demand for system capacity and scalability and the impact of all weather conditions on the whole system [10], [16].

In this paper, a hybrid has been created between Wavelength Division Multiplexing (WDM) multiple beams (MIMO) to obtain a new procedure for overcoming atmospheric weakening due to weather parameters and meeting the increasing demands for wide bandwidth and scalability, limited energy at the receiver, and restricted distance that a single beam travels. WDM is a multiplexing method in which many optical signals with different wavelengths are delivered across a single carrier. The improved performance of the FSO system has been noted. This research looks at two types of FSO systems: single beam (SISO) and multiple beam (MIMO), as well as how to construct the ideal system that can overcome air turbulence while maintaining a high data rate and scalability. It is proposed that the hybrid WDM multiple input multiple output (MIMO) system improves received power, distance between transmitter and receiver, geometrical losses, and scalability. The hybrid DWDM (MIMO) technology is the greatest contender for solving the last-mile problem and dealing with rapid capacity increases without the need for additional FSO transmitters and receivers.

The following elements make up the structure of this paper: Following the outline in the main part about the effect of environments conditions on the FSO broadcast structure in section I, section II describes the WDM and MIMO procedure, section III discusses fog, rain, and snow attenuation, section IV describes the proposed methods and the comparison between (FSO-WDM-SISO) technique and (FSO-Hybrid-DWDM-MIMO) technique in transmission link distance and quality factor, section V describes the discussion and results, and lastly section VI denotes the deduction.

2. Necessary contextual

2.1. WDM

WDM is a technique for increasing the communication system's capacity and scalability. In the realm of optical fiber communication systems, it's gaining prominence. The fundamental distinction between WDM and frequency division multiplexing (FDM) is the range of spectral frequencies or wavelengths used in each approach. Multiple data streams are transmitted with WDM by using different optical carriers with different wavelengths. Modified and filtered using a standard optical media. WDM can be utilized to share a significant amount of FSO's data

optimization functionality. Multiplexers in a WDM system combine data streams from multiple optical sources and send them over a single visible channel across an optical channel medium. De-multiplexers are data recovery devices installed at the end of a WDM communication system. WDM communication systems enable independent information bitrates and access protocols to operate on the same system [8], which is a critical requirement for the development of communication systems, including FSO systems, because it eliminates the cost of switching between protocols. Each optical channel has a predetermined protocol that can be treated (multiplexed/demultiplexed) at the ends of the independent transmission system, allowing for different data rates and access protocols to be used.

2.2. MIMO Configuration

Wireless system ushered in a slew of technological advancements in the fields of data transfer and information exchange. Single antenna used for the transmitter and single antenna used for the receiver in the typical SISO wireless communication system. However, modern wireless communication systems employ several antennas at the transmitter side and receiver end, a technique known as (MIMO). This technology employs multipath signal transmission across an free external location, also known as communication channel. The MIMO system can be used in FOS communication systems, where the transmitters are determined by the configuration of light-emitting diodes (LEDs) or lasers.

3. Effect of weather conditions

3.1. Fog Attenuation

Weather attenuation, caused by scattering and absorption, is the greatest barrier in implementing optical wireless communication. Water particles and carbon dioxide are the primary causes of wireless optical signal absorption; instead, fog, snow, cloud, and rain are the primary causes of wireless optical signal scattering. This scattering causes a portion of the transmission beam sent from the optical source to turn around and arrive to the anticipated receiver. Fog is a cloud of tiny particles of water, ice-smoke, or a mixture of the two that forms near the earth's surface and is the primary cause of light diffraction, which reduces vision [9]. When the weather is foggy, the most common way for calculating attenuation is to use information about visibility to find particular attenuation. The distance to an object when the picture difference it should be less than 5%, if it is close to the original image, [10] is defined as atmospheric visibility. The visibility is estimated at a wavelength of 550 nm, which corresponds to the sun spectrum's greatest intensity. The transmissometer measures visibility in airports and meteorological stations using a wavelength center of 550 nm and a bandwidth of 250 nm. There are two models that are frequently utilized. According to Kim and Kruse's models, fog attenuation can be estimated using the following formula [11]:

$$A_{FOG} \left(\frac{db}{km} \right) = \frac{10 \log(V\%)}{V \text{ km}} \left(\frac{\lambda_0}{\lambda} \right)^q \cong \frac{13 \text{ db}}{V \text{ km}} \left(\frac{550 \text{ nm}}{\lambda_{nm}} \right)^q \quad (1)$$

where:

λ is wavelength, q is particle size, V is visibility.

q, is calculated according to Kim model by the following equation.

$$q = \begin{cases} 0 & \text{if } v < 0.5 \text{ km} \\ v - 0.5 & \text{if } 0.5\text{km} < v < 1\text{km} \\ 0.16v + 0.34 & \text{if } 1\text{km} < v < 6\text{km} \\ 1.3 & \text{if } 6\text{km} < v < 50\text{km} \\ 1.6 & \text{if } v > 50\text{km} \end{cases} \quad (2)$$

$$q = \begin{cases} 0.585v^{\frac{1}{3}} & \text{if } v < 6 \text{ km} \\ 1.3 & \text{if } 6\text{km} < v < 50 \text{ km} \\ 1.6 & \text{if } v > 50 \text{ km} \end{cases} \quad (3)$$

The important difference between the two models, the Kruse model suppose a wavelength dependency and the Kim model suppose wavelength does not depend on attenuation for thick fog conditions.

3.2. Snowfall Attenuation

Because snowflakes are larger than raindrops, signal attenuation is greater than the rain's effect.

Large pieces of snow are considered the main reason for path link failure [11]. 20 mm snow pieces have been reported.

The snowy weather that causes the signal reduction is a function of the snow intensity (S) in (mm/h) and the signal wavelength. The specific attenuation is given by the equation below, which is like the attenuation due to snowfall based on classification into dry and wet snow types.

$$A \text{ snow (db/km)} = a S^b \quad (4)$$

Where (a, b) indicate the snow type (wet or dry) snow as follow:

- (a = 5.42 * 10⁻⁵λ + 5.4958776, b = 1.38), for dry snow
- (a = 1.023 * 10⁻⁴λ + 3.7855466, b = 0.72), for wet snow :

3.3. Rainfall attenuation

Since the limit of raindrops (100–1000) μm is substantially greater than the wavelength of normal FSO structures, rainfall scattering is known as non-selective scattering. The raindrop particle has a lower scattering impact when passing through the laser [12]. The rain attenuation model is used to calculate rain attenuation and is based on rain rate. The amount of optical signal attenuation is affected by the size and number of rain droplets that interrupt the route of the radiation, as well as the rainfall rate. The optical attenuation increases linearly with the rate of rainfall, but the regular size of raindrops decreases. The visual reduction because of rain duo to the rain amount or dens rate can be considered using Equation (5).

$$A \text{ rain} = 1.07 R^{\frac{2}{3}} \left(\frac{db}{km} \right) \quad (5)$$

where the rain rate is R (mm/h)

4. Proposed Methods

The graph representation of two alternative schematics proposed was addressed in detail in this section. FSO schematic mechanisms have been suggested and simulated with the help of Opti system simulator. The research was carried out on two different models, (FDS) and (FHDM) respectfully. The study compares the above models by considering the turbulent of the atmosphere, the transmission system is affected by weather conditions such as fog, rain, and snow, and taking into account the effect of each condition by calculating the quality factor at different weather conditions by varying the path length between the transmitter and receiver and attenuation that corresponds to each weather condition.

4.1. FDS Model:

The transmitter, channel, and receiver are the three components of the design employed in this study. As illustrated in figure, 16 WDM transmitters consist of a CW Laser power source, NRZ as a coder, a MZ-Modulator, and a Pseudo-random-generator. The optical source has a power of 20 dBm, a frequency of 193.1THZ, a channel spacing of 100 GHz, and an operational wavelength of 1550 nm. The channel is made up of an FSO-SISO system with different attenuations for different weather conditions. This diagram depicts the impact of fog, rain, and snow on the transmission system's performance. The transmitter's and receiver's apertures are (5 cm and 15 cm) respectively, and 500 Mbps bit rate.

4.2. FHDM Model:

This diagram represents the mutual effect of a DWDM-transmitter and a MIMO 4x4 channel-link. WDM-transmitter and channel features are comparable to previous models. The Graph representation of this schematic is shown in Figure (2). This schematic includes a 16 WDM, CW laser transmitter, and a 4x4 FSO-MIMO channel with a bit rate of 500 Mbps, a power supply of 20 dBm, and an NRZ encoder.

5. Result and discussion

The results obtained were used to compare performance of the FDS Model and proposed schematic FHDM model improved operating range under different weather conditions, as well as to choose which schematic should be adopted to take advantage of the channel properties to the maximum in this section.

- First point
- Second point

5.1 Behavior of FDS model for different environments

This section investigates the impact of clear and fog weather conditions on the performance of the WDM-SISO in clear weather with visibility greater than 10 km, as well as in various fog conditions such as light fog (0.5 > V > 10) km, regular fog (0.05 > V > 0.5) km, and thick fog (V > 0.05) km, using the Kim mathematical model previously mentioned in equation (1). The system is put to the test in different weather conditions, with attenuation values of (260 dB/km), (26 dB/km), (7.743 dB/km), (0.338 dB/km) in clear weather, light fog, regular fog, and deep fog, respectively. The simulation's outcomes are depicted in Figure (3).

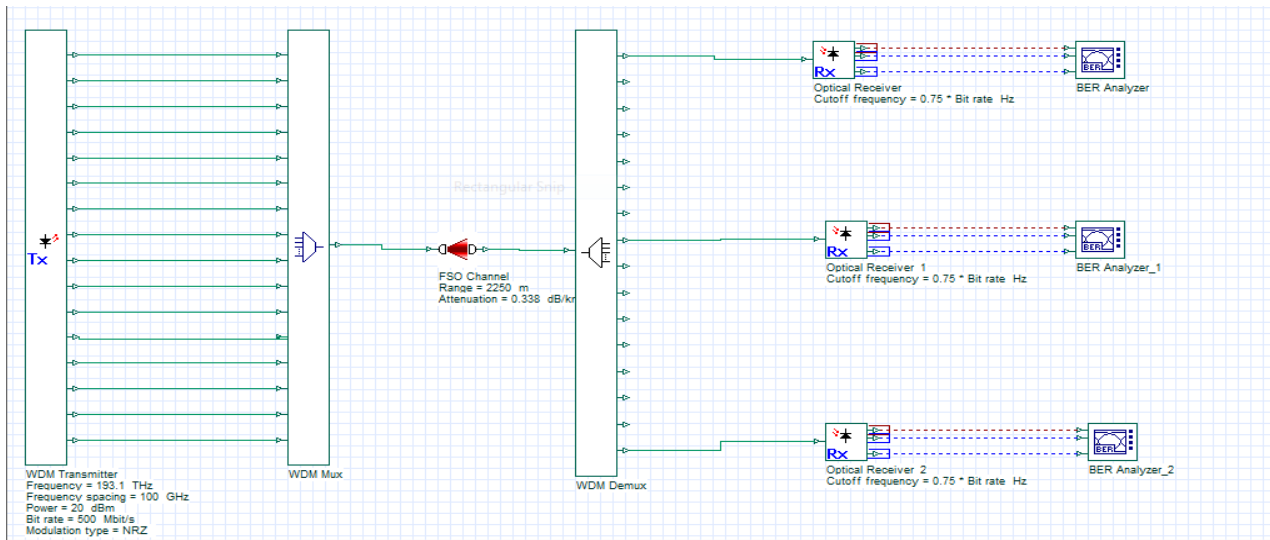

Figure 1. FDS Model

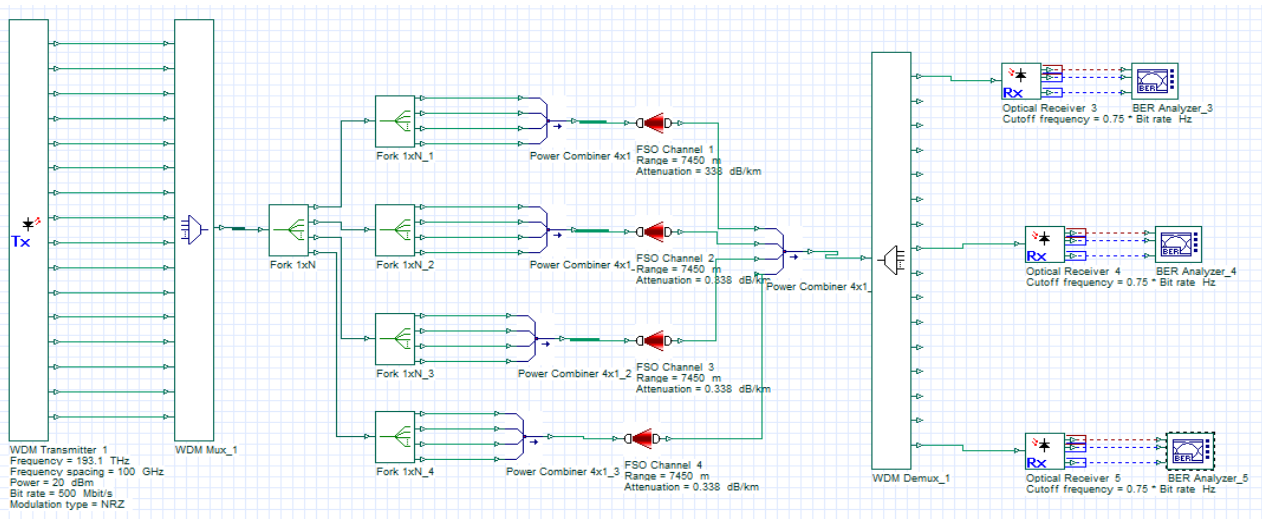

Figure 2. FHDM Model

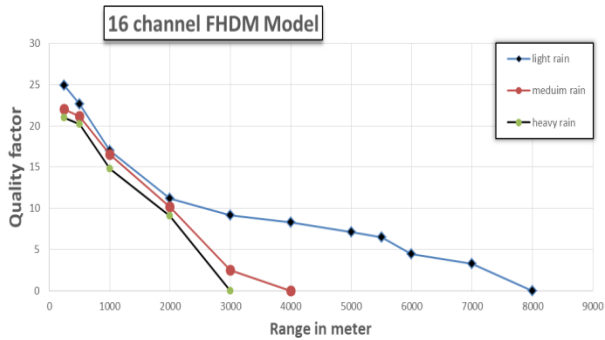

Figure 3. The Q factor with the variable system path length in clear weather, light fog, moderate fog, and dense fog weather conditions, respectively.

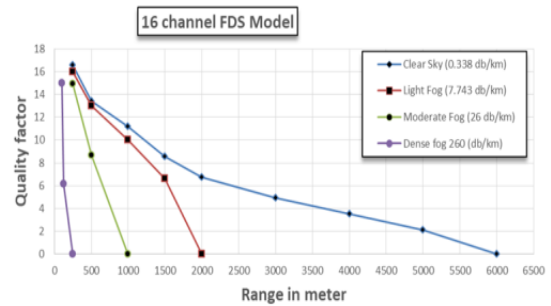

Figure 4. The Q factor with the variable system path length in, light rain, medium rain, and Heavy rain, respectively.

And, as shown in Figure 5, this study investigates the performance of DWMD-SISO in three scenarios of dry snow weather. The specific attenuation due to a dry snow weather condition can be calculated using the equation (3), which is dependent on the snow rate (s). The following are examples of simulated snow conditions: Dry, light, medium, and heavy snow are defined by average snow rates of 2.5 mm per hour, 5 mm per hour, and 10 mm per hour, respectively, for dry, medium, and heavy snow (s). The three types of snow that are simulated in this simulation are light, medium, and heavy. Each stage of dry snow has a specific attenuation of 19.356dB/km, 50.654dB/km, and 131.835dB/km for light, medium, and heavy wet snow, respectively.

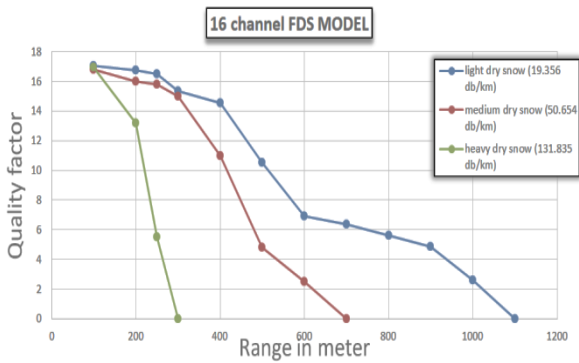

Figure 5. The Q factor with the variable system path length in, light rain, medium rain, and Heavy rain.

5.1. FHDM model under several weather conditions

In clear weather, light fog, moderate fog, and dense fog, the attenuation is equal to (260 dB/km), (26 dB/km), (7.743 dB/km), (0.338 dB/km). This model aspects the performance of the proposed FHDM system in three different rainy weather scenarios (light, medium, and heavy rain), with specific attenuation values of 1.988 dB/km, 5.8444 dB/km, and 9.2989 dB/km for light, medium, and heavy rain.

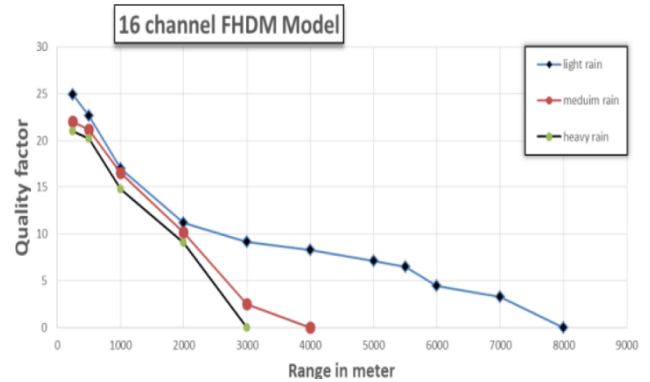

Figure 7. The Q factor with the variable system path length in, light rain, medium rain, and Heavy rain.

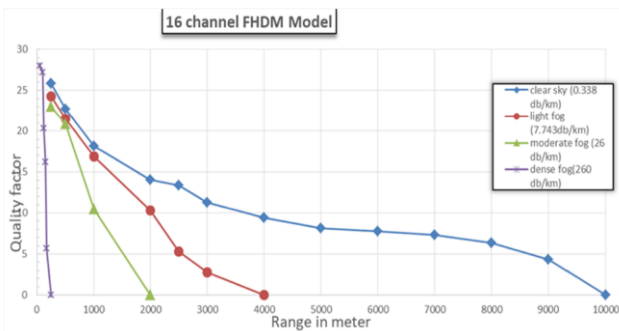

Figure 6. The Q factor with the variable path length in clear weather, light fog, moderate fog, and dense fog weather conditions.

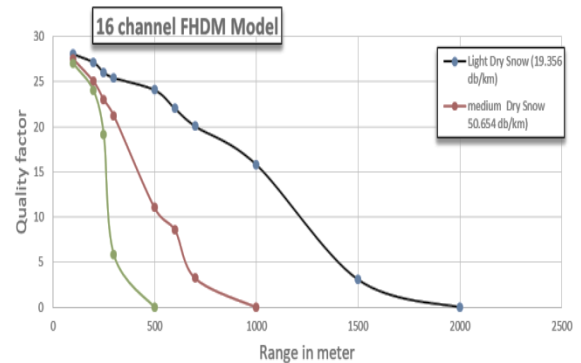

Figure 8. The Q factor with the variable system path length in, light Dry snow, medium dry snow, and Heavy dry snow.

Table 1. An example of a table.

Number of channel	Clear sky	Light fog	Regular fog	Thick fog	Light rain	Regular rain	Thick rain	Light dry snow	Regular dry snow	Heavy dry snow
	0.388	7.743	26	260	1.988	5.8444	9.29	19.356	50.54	131.835
	dB/km	dB/km	dB/km	dB/km	dB/km	dB/km	dB/km	dB/km	dB/km	dB/km
16 channel										
FSO-WDM-SISO	2250	1510	600	115	2150	1625	1350	775	450	210
16-channel										
FSO-hybrid	7450	2430	1055	150	5140	2900	2100	1265	600	265

According to the results from the preceding section for FDS performance, because the attenuation (absorption, scattering) increases. The results obtained from the FHDM showed a difference in the quality factor to the best in comparison to the results obtained from FWS as shown in Table (1). The results also showed in the maximum transmission path length for each case under different environments because using multiple input multiple output technique (MIMO) it produced redundancy transmission path length that overcomes the problem of obstacles and makes a more reliable transmission path length.

6. Conclusions

FSO is the most viable alternative among other connection technologies when a high data rate link is required for a specific application of terrestrial and space communication. Despite its main benefits, such as high data rate and capacity, this approach has obstacles, mostly due to various weather conditions in the Earth's atmosphere, such as snow, clouds, fog, and rain. The results of our system's implementation and modeling demonstrated that the FSO-WDM-SISO and FHDM of a 16-channel DWDM FSO system performed well in a variety of weather circumstances, including clear and foggy conditions, rain, and dry snow. The 10-Gb/s16PSK-OFDM-FSO system is suggested and investigated using a practical implementation scheme. A short-range communication link simulation is run under various weather conditions. Optical spectrum diagrams, constellation diagrams, and BER performance of received signals are all measured at the receiver. When the weather changes from cloudy to wet to foggy, the receiver's sensitivity degrades. The constellation's divergence degree is extreme on foggy days, and phase information is obscure. The 16PSK-OFDM-FSO system offers good transceiver performance and is user-accessible, according to simulation results. As a result, the FSO system is a good long-distance, high-capacity, and flexible access solution plan. This paper shown that when the TX/RX of the system is increased, the maximum transmission path length and quality factor rise. The suggested method improves the performance of the system by combining WDM and MIMO techniques.

Declaration of competing interest

The authors declare no conflicts of interest.

Funding source

This study didn't receive any specific funds.

REFERENCES

- [1] A. B. Mohammad, "Optimization of FSO system in tropical weather using multiple beams," in *2014 IEEE 5th International Conference on Photonics (ICP)*, 2014, pp. 109–112.
- [2] S. Kaur and A. Kakati, "Analysis of free space optics link performance considering the effect of different weather conditions and modulation formats for terrestrial communication," *J. Opt. Commun.*, 2018.
- [3] S. Kaur, "Analysis of inter-satellite free-space optical link performance considering different system parameters," *Opto-Electronics Rev.*, vol. 27, no. 1, pp. 10–13, 2019.
- [4] A. Ahmed, A. Singh, A. Singh, and S. Kaur, "Performance Analysis of WDM-MIMO Free Space Optical System Under Atmospheric Turbulence," in *2019 6th International Conference on Signal Processing and Integrated Networks (SPIN)*, 2019, pp. 820–825.
- [5] N. H. M. Noor, A. W. Naji, and W. Al-Khateeb, "Performance analysis of a free space optics link with multiple transmitters/receivers," *IJUM Eng. J.*, vol. 13, no. 1, 2012.
- [6] F. D. Kashani, M. R. Mahzoun, and B. Ghafary, "Beam propagation analysis of a multi beam FSO system with partially flat-topped laser beams in turbulent atmosphere," *Optik (Stuttg.)*, vol. 123, no. 10, pp. 879–886, 2012.
- [7] N. H. M. Noor, W. Al-Khateeb, and A. W. Naji, "Experimental evaluation of multiple transmitters/receivers on free space optics link," in *2011 IEEE Student Conference on Research and Development*, 2011, pp. 128–133.
- [8] V. Manea, M. Petre, S. Puşcoci, and D. A. Stoichescu, "The approach of wavelength dense multiplexing using free space optical systems," in *2016 8th International Conference on Electronics, Computers and Artificial Intelligence (ECAI)*, 2016, pp. 1–6.
- [9] M. S. Awan, E. Leitgeb, S. S. Muhammad, F. Nadeem, M. S. Khan, and C. Capsoni, "Distribution function for continental and maritime fog environments for optical wireless communication," in *2008 6th International Symposium on Communication Systems, Networks and Digital Signal Processing*, 2008, pp. 260–264.
- [10] F. Nadeem, V. Kvicera, M. S. Awan, E. Leitgeb, S. S. Muhammad, and G. Kandus, "Weather effects on hybrid FSO/RF communication link," *IEEE J. Sel. areas Commun.*, vol. 27, no. 9, 2009.
- [11] F. Nadeem, E. Leitgeb, M. S. Awan, and G. Kandus, "Optical wavelengths comparison for different weather conditions," in *2009 International Workshop on Satellite and Space Communications*, 2009, pp. 279–283.
- [12] Wali, Musa H., Ali Khalid Jassim, and Hasan Ma Almgotir. "Design and analysis 5G mobile network model to enhancement high-density subscribers." *Bulletin of Electrical Engineering and Informatics* 10.3 (2021), pp. 1464-1474.
- [13] A. Alkholidi and K. Altowij, "Effect of clear atmospheric turbulence on quality of free space optical communications in Western Asia," *Opt. Commun. Syst.*, pp. 41, 2012.
- [14] Abdullah, Abdulkareem S., Ramzy S. Ali, and Musa H. Wali. "Design and analysis of compact H-like element microstrip reflectarray antenna for X-band applications." *British Journal of Applied Science & Technology* 4.34 (2014), pp. 4807.
- [15] L. W. Abdullah, A. H. Sallomi and M. H. Wali, "A Sixteen Mode Frequency Reconfigurable Antenna for Underlay Cognitive Radio," *2021 IEEE 19th Student Conference on Research and Development (SCORED)*, 2021, pp. 146-151.
- [16] L. W. Abdullah, A. H. Sallomi and M. H. Wali, "Twelfth mode on-demand band notch UWB antenna for underlay cognitive radio," *Indonesian Journal of Electrical Engineering and Computer Science*, 2021, pp. 1446~1456.