

## SELF COMPACTING CONCRETE INCORPORATING RICE HUSK ASH AND METAKAOLIN

Jinan Jawad Hassan Alwash  
Lecturer  
Babylon University  
College of Engineering  
E-mail:genan\_gwad@yahoo.com

### ABSTRACTE

This research deals with the effect of rice husk ash (RHA) and Metakaolin (MK) as a partial replacement for ordinary Portland cement (OPC) on properties of self – compacting concrete (SCC). Three different replacements of RHA ( 5% , 10% and 15%) and one replacement of Metakaolin (15%) were used for SCC.

To determine the workability, three test methods were adopted, slump\_flow, L.box and V\_funnel.

The experimental results showed that (RHA) improved the strength and modulus of elasticity of SCC at age after 60 days . The optimum strength was at 15% replacement . Specimens with 15 % replacement of ( MK) showed a better strength and modulus of elasticity at all ages . Also the use of ( RHA and MK) caused reduction in water absorption and increase the ultrasonic pulse velocity.

**Keywords:** rice hush ask(RHA ), pozzolan; metakaolin(MK), self compacting concrete( SCC)

### الخرسانة ذاتية الرص الحاوية على رماد قشور الرز والميتاكاولين

جنان جواد حسن علوش  
جامعة بابل / كلية الهندسة / قسم الهندسة المدنية

### الخلاصة

يتناول هذا البحث دراسة تأثير رماد قشور الرز والميتاكاولين (كاد دال ست جزء من وزن السمنت البورتلاندي الاعتيادي) على خواص الخرسانة ذاتية الرص. ثلاث نسب ( استبدال) من رماد قشور الرز ( 5% ، 10% و 15% ) ونسبة ( استبدال ) واحدة من الميتاكاولين ( 15%) استخدمت لعمل خرسانة ذاتية الرص. استخدمت ثلاث طرق لقياس قابلية التشغيل للخرسانة الطرية ،فحص الانسياب والصندوق على شكل حرف L والقمع على شكل حرف V.

أشارت النتائج إلى إن رماد قشور الرز تحسن من مقاومة ومعامل مرونة الخرسانة ذاتية الرص بعد عمر 60 يوم ، والمقاومة المثلى كانت عند استبدال ( 15%) رماد قشور الرز من وزن السمنت . إن النماذج الحاوية على ( 15%) ميتاكاولين من وزن السمنت أظهرت أفضل مقاومة ومعامل مرونة لكافة الأعمار ، كذلك استخدام رماد قشور الرز والميتاكاولين تسبب انخفاض في امتصاص الماء . وزيادة في سرعة الأمواج فوق الصوتية .

#### NOMENCLATURE

<b>Ec</b>	<b>Static Modulus of Elasticity</b>
<b>F</b>	<b>Fineness Modulus</b>
<b>F<sub>t</sub></b>	<b>Flexural Strength</b>
<b>G</b>	<b>Specific Gravity</b>
<b>L</b>	<b>Span Length</b>
<b>MK</b>	<b>Metakaolin</b>
<b>OPC</b>	<b>Ordinary Portland Cement</b>
<b>P</b>	<b>Maximum resisted Load</b>
<b>RHA</b>	<b>Rice Husk Ash</b>
<b>SCC</b>	<b>Self Compacting Concrete</b>

#### INTRODUCTION

SCC was first developed in Japan 1980 in order to reach durable concrete structures [Campion et al, 2000] . In recent years , a lot of study was done on how to improve the performance of concrete , especially on topics regarding how to increase the strength , durability and flow ability of concrete .

SCC has been described as "the most revolutionary development in concrete construction for several decades ' [ Colaco et al, 1981] . SCC describes a concrete with the ability to compact it self only by means of its own weight without the requirement of vibration . It fills all voids, even in highly reinforced concrete members and flows free of segregation nearly to level balance [ Tilo et al, 2002]. Due to its specific properties , SCC may contribute to significant improvement of the quality of concrete structures and open up new fields for the application of concrete. It can be used in repair applications, hard to reach areas , areas with congested reinforcement such as columns and walls, durable concrete , fair face concrete pumped concrete for long distances besides all other normal concrete applications. SCC is different from the conventional concrete in that it has a lower viscosity and , thus , a greater flow rate even when pumped [ Celic et al, 2003]

SCC mixes generally have a much higher content of fine fillers, including cement and produce excessively high compressive strength concrete, which restricts its field of application to special concrete only. To use SCC mixes in general concrete construction practice , requires low cost materials to make inexpensive concrete.

Rice husk is an agro – waste material which is produced in about millions of tons. Approximately, 20 kg of rice husk are obtained for 100 kg of rice . Rice husk contain organic substances and 20% of inorganic material. (RHA) is obtained by the combustion of rice husk . The most important property of RHA that determines pozzolanic activity is the amorphous phase content . RHA is a highly reactive pozzolanic material for use in lime – pozzolana mixes and for Portland cement replacement. RHA contains a high amount of silicon dioxide, and its reactivity related to lime depends on a combination of two factors, namely the non -crystalline silica content and its specific surface [Akindahunsi and Alade , 2010] .

[ **Mahmud et al, 2004** ] studied the use of RHA to produce high strength concrete and the effect of the addition or replacement of RHA compared to silica fume on fresh and hardened mechanical properties .In this investigation ordinary Portland cement (OPC), RHA, silica fume (SF) and sulphonated naphthalene formaldehyde based super plasticizer was used as chemical admixture with varying amounts to maintain workability . The results showed that the addition of RHA up to 15% leads to increase the compressive strength , increasing the amount above these values decreases the strength of the concrete . The optimum addition level of RHA to produce HSC approximately 10% and the optimum cement replacement with RHA is about 5%.

[**AL–Abdaly, 2007**] studied the effect of the addition of Rice Husk Ash (RHA) in two percentages (5, 7.5)% by weight of cement on the mechanical properties and drying shrinkage of high strength concrete . She found that the addition of RHA to concrete causing a deficiency by about (16-34) % for compressive strength , (11-16)% for splitting tensile strength , (4-11) % for modulus of elasticity and (7-43) % for drying shrinkage. This reduction was observed for two percentages of RHA (5, 7.5)% .

Metakaolin differs from other supplementary cementitious materials (SCMs) , such as fly ash , silica fume , and slag , in that it is not a by – product of an industrial process ; it is manufactured for a specific purposes under carefully controlled condition . Metakaolin is produced by heating kaolin , one of the most abundant natural clay minerals, to temperatures of (650 -900) C° . This heat treatment or calcination , serves to break down the structure of kaolin . Bond hydroxyl ions are removed and resulting disorder among alumina and silica layer yields a highly reactive , amorphous material with pozzolanic and latent hydraulic reactivity , suitable used as partial replacement for Portland cement , Metakaolin may improve both the mechanical properties and the durability of concrete [**Bai J and Gailivs A , 2009** ]

## **EXPERIMENTAL WORK**

### **Materials and mixes**

#### **Cement**

Ordinary Portland cement (OPC) manufactured by united cement company , commercially known (TASLUJA – BAZIAN) was used throughout this investigation .This cement complied with the Iraqi specification No.5:1984 .The chemical composition and physical properties are presented in Tables (1) and (2).

#### **Fine Aggregate (Sand):**

Kerbala sand brought from AL-Akhaidher region was used as fine aggregate in the present study .Sieve analysis and other properties of this sand are listed in Table (3).

#### **Coarse Aggregate (Gravel)**

Rounded river gravel from Al-Nebae region was used as coarse aggregate in the present work Its gradation and other properties are listed in Table (4). The maximum size of gravel was 14 mm which preferred for SCC [**Ali 2006**]

#### **Super plasticizer**

To a chive high workability needed to produce SCC, super plasticizer known as Flocrete SP33 was used. According to ASTM C 494-92, this sp is classified as type A and F .The technical description of super-plasticizer is given in Table (5).

#### **Rice Husk Ash(RHA)**

Burning of rice husks according to [**Habeeb, 2000 and Hana, 1984**]was carried out in a furnace with controlled temperature in order to establish the optimum burning temperature and burning time. The produced ash was burnt at a temperature of 500 C° for two hours. The ash was grounded by Los Angeles Machine ,and to produce finer ash it will be grounded by small mill. The chemical composition of the RHA is given in Table (6) .

## Metakaolin

Metakaolin is a highly pozzolanic material produced by calcining the clay using an oven at temperature of (750) C° for 1 hour.. The particle passing sieve size (0.0015 mm). The chemical composition of metakaolin is shown in Table (7).

## Mix Design and proportions

The Japanes mix design procedure (cited by EFNARC2002) was followed to design the mix proportion of SCC. For the experiments, five series of self compacting concrete were mixed : Three different replacement percentages of cement by RHA,5%, z10% and 15% : one mix with partial replacement (15%) Of MK as cement with mix have no (RHA or MK) . The mixture proportions are reported in Table (8).

## Fresh Concrete Testing

The fresh concrete tests below are specially devised to assess filling ability (flowability), passing ability (passibility) and segregation resistance (stability) of SCC. But, there is no unique test so far devised to measure the three properties together. It is important to mention that none of the fresh SCC test methods has yet been standardized, and the tests described below are not yet perfected to definitive (EFNARC, 2002). These testes are:

### 1. Slump Flow Test.

It is the most commonly used test and gives a good assessment of filling ability. The apparatus is shown in Fig (1). At first, the inside of slump cone and the smooth leveled surface of floor on which the slump cone is to be placed were moistened. The slump cone was held down firmly. The cone is then filled with concrete. No tamping is done. Any surplus concrete was removed from around the base of the concrete. After this, the cone was raised vertically and the concrete was allowed to flow out freely. The diameter of the concrete in two perpendicular directions was measured. The average of the two measured diameters was calculated. This was the slump flow in mm. The higher the slump flow value, the greater its ability to fill formwork under its own weight.

### 2. L.box test method.

It assesses filling and passing ability of SCC. The apparatus is shown in Fig (2). The vertical section was filled with concrete, and then gate lifted to let the concrete flow into the horizontal section. When the flow has stopped, the heights ( $H_1$ ) and ( $H_2$ ) were measured. Closer to unity value of ratio(  $H_2/H_1$ ) indicates better flow of concrete.

### 3- V- Funnel Test

The test measures flowability of concrete. The apparatus is shown in Fig (3). At first, the test assembly was set firmly on the ground and the inside surfaces were moistened. The trap door was closed and a bucket was placed underneath. Then the apparatus was completely filled with concrete without compacting. After filling the concrete, the trap door was opened and the time for the discharge was recorded.

## Hardened Concrete Testing. Compressive Strength.

Concrete cubes of (150 mm) were used to measure the compressive strength of SCC at the ages of (7, 28, 60 and 90) days. This test was performed according to "BS 1881: part 116: 1989" The cubes were moist cured until the age of testing.

## Flexural Strength

SCC prisms of dimensions (100×100×400)mm were cast and tested for flexural strength determination. This test was performed according to "BS 5328: Part 4 :1990" specification. The

concrete prisms were moist cured until the age of testing (28, 60, 90) days. This test was performed using two-point load. Flexural strength ( $f_t$ ) is calculated from the following equation:

$$F_t = \frac{PL}{bd^2} \quad \dots(1)$$

Where:

P = maximum resisted load, N.

L = span length, mm.

b = specimen width, mm.

d = specimen depth, mm.

### Modulus of Elasticity.

Concrete cylinder of dimensions (150×300)mm were used to determine modulus of elasticity. This test was performed according to "ASTM C469-2002" specification . The cylinders were moist cured until the age of testing (28 and 60) days. The test was conducted by subjecting the cylinder to a compression load until failure. Two steel proving rings clamped to the cylinder leaving 200 mm gauge length between each other. A dial gauge (0.01 mm/div) accuracy was fixed between the proving rings to measure contraction strain in the concrete cylinders due to the applied compression. The modulus of elasticity  $E_c$  is calculated using the following equation:

$$E_c = \frac{(S_2 - S_1)}{(\varepsilon_2 - \varepsilon_1)} \quad \dots(2)$$

Where:

$E_c$  = static modulus of elasticity, GPa

$S_2$  = stress corresponding to 40% of ultimate load, GPa

$S_1$  = stress corresponding to a longitudinal strain of  $50 \times 10^{-6}$ , GPa

$\varepsilon_2$  = longitudinal strain produced by  $S_2$

$\varepsilon_1 = 50 \times 10^{-6}$

### Water Absorption

Cube specimens with 100 mm were used for the water absorption test. This test was conducted according to BS. 1881. part 122-1989 after (28 days) of moist curing. These specimens were dried in an oven at ( $105 \pm 5^\circ\text{C}$ ) for (72 hours), then the specimens were immersed in water for (24 hours). The percentage of total absorption was calculated with the following equation:

$$\text{Absorption}(\%) = (W_2 - W_1) / (W_1) \times 100 \quad \dots(3)$$

Where:

$W_1$  = The average weight of dry specimens (gm).

$W_2$  = The average weight of wet specimens (gm).

### Ultrasonic Pulse Velocity Test

The UPV method can be considered as one of the most promising methods for evaluation concrete structures. This method basically depends on the propagation of high frequency sound wave, which passes through the material by using portable equipment (PUNDIT), composed of the source / detector unit and the surface transducers, which work in the frequency range of 25 to 60

KHz. The ultrasonic pulses depend on the density and elastic properties of material [Lorenzi et al, 2007].

150 mm cubes were used to measure the propagation velocity of longitudinal stress wave pluses through concrete. The test was performed according to [ASTM C597, 2002]. Pulses of longitudinal stress wave are generated by electro-acoustical transducer that is held in contact with one surface of the concrete under test. After traversing through the concrete, the pulses are received and converted into electrical energy by a second transducer. The pulse velocity is given by the following equation:

$$V = \frac{L}{T} \quad \dots(4)$$

Where:

V : Pulses velocity, (km/sec)

L : Distance between center of transducer faces, (mm)

T : Transit time, ( $\mu$  sec)

\* All test were conducted in the constructional and materials laboratory in University of Babylon .

## RESULTS AND DISCUSSION

### A – Fresh concrete properties

Table (9) gives the experimental results obtained from slump flow, L.box and V-funnel tests that were conducted throughout the present work. It can be seen that the test results are within the limits of self-compacting concrete results established in (EFNARC 2002). The results of slump flow test show that the flow decreased with increase quantity of RHA , by addition of ( 5%) RHA the flow decreased by ( 1.26%) , at ( 10%) the flow decreased by ( 4.43%) and at ( 15%) the flow decreased by ( 6.96%). The results of L.box test show that the ratio of L.box decreased with increase quantity of (RHA). On the other hand ,it can be seen from Table (9) that the mix containing 15% MK showed lower slump value when compared with mix have no (RHA and MK) and the amount of reduction was ( 6.32%) . The reason for this behaviour is attributed to increasing of the surface area of the fine materials content which increases the inter- particles friction .

### B- Hardened concrete properties

For compressive strength the specimens were tested at different ages from 7 to 90 days. The results are shown in Table (10) and Fig (4). According to the results, SCC mixes containing RHA indicate lower compressive strength until 60 days rather than samples with no replacement, but by increasing the rate of pozzolanic reactions of RHA in the matrix, strength of composite mixes goes up. The SCC mixes containing 15 % RHA have the highest compressive strength among the others. According to [Rodriguez, 2006] the RHA concrete had higher compressive strength at 91 days in comparison to that of the concrete without RAH. The increase in compressive strength of concretes with residual RAH may also be justified by the filler (physical) effect. It is concluded that RAH can provide a positive effect on the compressive strength of concrete at early ages, besides, in the long term, the compressive strength of RAH blended concrete produced by controlled incineration shows better performance. [Mahmud et al ,1996 ] reported 15% cement replacement by RHA as an optimal level for achieving maximum strength . On the other hand, it can be seen from Table (10) and Fig (4) that ( 15%) of (MK) by weight of cement enhances compressive strength at all ages . The addition of(MK) into the matrix improves the bond between the cement paste and the aggregate particles as well as increasing the density of the cement paste , which in turn significantly improves the compressive strength of the concrete .According to the literature , the main factors that affect the contribution of (MK) in the strength are a- The filling effect , b – The dilution effect and c – The pozzolanic reaction of ( MK) with CH [ Wild S et al, 1996 ] .

For flexural strength the specimens were tested at 28, 60 and 90 days age and test results have been shown in Table (11) and Fig (5) . In flexural strength like compressive one, mixes containing RHA indicate lower flexural strength until 60 days compared to samples with no replacement , at 28 days the flexural strength decreased by ( 3.44% , 6.89 % and 12.06%) when RHA was used (5% , 10% and 15%)respectively, and by increasing the rate of pozzolanic reactions of RHA in the matrix, strength of the composite mixes goes up. Also, the SCC mixes containing 15 % rice husk ash have the highest flexural strength in all cases. [Habeeb et al, 2009] investigated the effects of concrete incorporating 20 % RAH as a partial replacement of cement at three different particle sizes in their study the tensile strength and flexural strength of concrete increased systematically with increasing RAH replacement. On the other hand it can be observed in inclusion of (15%MK) as partial replacement of cement cause increase in flexural strength of SCC by about (8.6% , 16.9% and 16.5% ) for ages ( 28 , 60 and 90 ) days respectively .

Table (12) and Fig (6) demonstrates the experimental values of modulus of elasticity at 28 and 60 days age for SCC of specimens .It can be seen that the influence of ( RHA and MK) on the modulus of elasticity is similar to that of strength .The general trend of increasing the compressive strength leading to increase modulus of elasticity [ Neville,1995].

The water absorption at 28 day is shown in Table (13) and Fig (7) .The results reveal that higher substitution amounts results in lower water absorption values, it occurs due to the fact that (RHA and MK) is finer than cement . Adding 15% RHA to SCC, a reduction of (24.2) % in water absorption is observed when compared to mix has no replacement. Also adding 15% MK to SCC , a reduction of (21.2) % in water absorption when compared to mix has no replacement .

Table (14) present the values of U.P.V at 28 and 60 days age. It can be seen that inclusion of (RHA) as partial replacement of cement enhances the U.P.V of SCC. Increase in pulse velocity was (1.1%, 2.3% , 3.2 %) at 28 days age and (1.5 % , 2.4 % , 3.3%) at 60 days age for corresponding RHA ( 5 % , 10 % and 15 % ) respectively . As well as the inclusion of ( 15 % MK ) as partial replacement of cement enhances the U.P.V OF SCC .

## CONCLUSION

- 1- Results indicate pozzolanic reactions of rice husk as in the matrix composite were low in early ages, but by aging the specimens to more than 60 days considerable effect has been seen in strength.
- 2- When ( 15%MK) replaces cement its positive effect on the concrete strength generally start at early ages and also noticeable increase in the strength was observed at later ages .
- 3- The inclusion of (RHA and MK) as partial replacement of cement leads to decrease the absorption of self compacting concrete.
- 4- Inclusion of (RHA and MK) as partial replacement of cement enhances the U.PV of SCC.

## REFERENCES

1. AL- Abdaly , N.M., 2007, " Drying Shrinkage Cracking of High Strength Concrete", M.Sc thesis , University of Babylon .
2. Ali, Esam, M, 2006, "Effect of Type of Filler and Water to Powder Ratio on Some Mechanical Properties of Self-Compacting Concrete", M.Sc Thesis, Babylon University.
3. Akindahunsi , A .A and Alade .O , June 2010, "Exploiting The Potentials of Rice Husk Ash as Supplement in cement for Construction in Nigeria " , International Journal of Concrete Structures and Materials .Vol 4 , No 1.
4. BS. 1881. Part 122. 1989, "Method for Determination of Water Absorption British Standards".

5. BS 1881: Part 117: 1989, "Method for Determination of Compressive Strength of Concrete Cubes", British Standards Institution, 2 Park Street. London.
6. BS 1881: Part 121: 1983, "Method for Determination of The Static Modulus of Elasticity in Compression", British Standards Institution, 2 Park Street, London.
7. Bai j . and Gailivs A., 2009, " Consistency of Fly ash and Metakaolin Concrete ", Journal of Civil Engineering and Management , pp.131 – 135.
8. Campion M . and Jost P., April 2000, " SCC: Expanding The Possibilities of Concrete Design and placement ", Concrete International , No .4, pp. (31-34).
9. Celik O . and Stephen L., June 2003, "Final Report; Evaluation of Self – Consolidating Concrete ", VTRC O3 –R 13 , Virginia , pp( 1-15).
10. Colaco J ., Ames B . and Dubinsky E. 1981," Concrete Shear Walls and Soandrel Beam Moment Frame Brace New Yourk Office Tower ", Concrete International, pp (23-28).
11. EFNARC, 2002, "Specifications and Guidelines for SCC", 99 Waste
12. Street, Farnham, Feb. ([www.efnarc.org](http://www.efnarc.org)).
13. Habeeb, G. M., 2000, "Residual Mechanical Properties of High Strength Concrete Subjected to Elevated Temperatures", ph. D, Thesis, University of Al-Mustansiriyah, College of Engineering, November.
14. Habeeb, G. A., and Fayyadh, M. M. 2009, "Rice Husk Ash Concrete: The Effect of RHA Average Particle Size on Mechanical Properties and Drying Shrinkage". Australian Journal of Basic and Applied Sciences 3(3).
15. Hana. A. Y., Moayad N. K., 1984, "Use of Rice Husk Ash in Concrete," The International of Cement Composites and Light Weight Concrete. Volume 6. Number 4. Degussa, Chemicals, pp.241-248.
16. " Iraqi Organization of Standards , IQS ' , 5: 1984 , for Portland Cement .
17. " Iraqi Organization of Standards , IQS ' , 5: 1984 , for Aggregate .
18. Lorenzi, A., Tisbierek, F., and Filho, L., 2007, "Ultrasonic Pulse Velocity Analysis in Concrete Specimens", Published by: IV Conference Panamericana de End, Brazil.
19. Mahmud , H. B , Hamid, N.B.A.A., and Chia, B.S ,1996, " High Strength Rice Husk Ash- A Preliminary Investigation, "
20. 3rd Asia Pacific Conferences on Structural Engineering and Construction.
21. Mahmud , H. B., Koay , Y.C.N. Hamid , B.A.A., and Zain , M.F.M., 2004." Use of Rice Husk Ash to produce High Strength / High Performance Concrete ," . National University of Malaysia
22. -Nevile , A.M.,1995."properties of concrete ," Four and Final Edition , Wiley , New York and long man , London .



23. Methe, P. K., 1992, "Rice Husk Ash- a Unique Supplementary Cementing Material, "in: V. M. Malhotra (Ed). Proceedings of the International Symposium on Advances in Concrete Technology. CANMET/ACI, Athens, Greece, May.
24. Rodriguez, G. S. 2006, "Strength Development of Concrete with Rice-Husk Ash", Cement and Concrete Composites. 28(2).
25. -Tilo P . and Carl A. 2002, " Pressure of Formwork and Ability to Deaerate ", Concrete Journal , No.17
26. -Wild S , Khatib JM , Jones A, 1996, " Relative Strength , Pozzolanic Activity and Cement hydration in superplasticized Metakaolin Concrete ", Cement Concrete Research 26 : 1537 – 1544.

**Table (1): Chemical composition of the cement**

<b>Oxides</b>	<b>% by weight</b>	<b>Limits of Iraqi specification IQS No.5/1984</b>
CaO	62.05	-----
SiO <sub>2</sub>	21.36	-----
Al <sub>2</sub> O <sub>3</sub>	5.68	-----
Fe <sub>2</sub> O <sub>3</sub>	3.52	-----
MgO	3.25	< =5%
SO <sub>3</sub>	2.51	< = 2.5 if C <sub>3</sub> A < 5% < = 2.8 if C <sub>3</sub> A > 5%
Free lime	1.12	—
L.O.I	1.22	≤ 4%
<b>Compound Composition</b>	<b>% by weight</b>	<b>Limits of Iraqi specification IQS No.5/1984</b>
C <sub>3</sub> S	35.36	----
C <sub>2</sub> S	34.56	----
C <sub>3</sub> A	9.1	----
C <sub>4</sub> AF	10.71	----
L.S.F	0.86	0.66 – 1.02

**Table (2) Physical properties of cement**

<b>Physical properties</b>	<b>Test Results</b>	<b>Limits of Iraqi specification IQS No.5/1984</b>
Fineness, Blaine, cm <sup>2</sup> /gm	3000	≥ 2300
Setting time, vicat's method		
Initial hrs: min	2:20	≥ 00:45
Final hrs: min	3:55	≤ 10:00
Compressive strength Mpa		
3days	19.0	≥ 15:00
7days	27.0	≥ 23:00

**Table (3):Grading and other properties of fine aggregate .**

Sieve size	Cumulative passing%	Limits of Iraqi specification IQS No.45/1984 for zone(2)
9.5 mm	100	100
4.75 mm	97	90-100
2.36 mm	82	75-100
1.18 mm	71	55-90
0.6 mm	55	35-59
0.3 mm	27	8-30
0.15mm	4.0	0-10
Physical properties	Test results	Limits of Iraqi specification IQS No.45/1984.
Specific gravity G	2.55	----
Sulfate contents as SO <sub>3</sub>	0.35%	≤ 0.5%
Absorption	1.5%	---
Fine materials ( passing No 200)	0.9%	≤ 5%
Fineness modulus Fm	2.64	----

**Table ( 4 ) : Grading and other properties of coarse aggregate.**

Sieve size	Cumulative passing %	Limits of Iraqi specification No.45/1984
20	100	100
14	100	90 – 100
10	51	50 – 85
5	9	0 – 10
2.36	0	—
Physical properties	Test results	Limits of Iraqi specification No.45/1984.
Specific gravity G	2.65	—
Sulfate content as SO <sub>3</sub>	0.07	≤ 0.1%
Absorption	0.5%	—
Fine materials	0.0%	≤ 3%

**Table (5 ):Technical description of the super plasticizer**

Color	Brown liquid
Freezing point	-2C° approximate
Specific gravity	1.18kg/l @ 25 C°
Air entrainment	Less than 2%
Chloride content	Nil

**Table(6 ) : Chemical properties of RHA**

Oxides	CaO	SiO <sub>2</sub>	Al <sub>2</sub> O <sub>3</sub>	Fe <sub>2</sub> O <sub>3</sub>	K <sub>2</sub> O	Na <sub>2</sub> O	MgO	SO <sub>3</sub>	MnO	Cl	L.O.I
Percentage	1.31	87.5	0.5	0.24	3.3	1.2	0.4	1.7	0.07	0.53	3.05

**Table ( 7 ) : Chemical composition of Metakaolin**

Oxide	Metakaolin %
SiO <sub>2</sub>	69.56
Al <sub>2</sub> O <sub>3</sub>	13.80
Fe <sub>2</sub> O <sub>3</sub>	1.95
CaO	2.52
MgO	1.2
SO <sub>3</sub>	0.05
L.O.I	5.1

**Table( 8 ) : Mix Design**

Mix designation	Cement Kg/ M <sup>3</sup>	Sand Kg/ M <sup>3</sup>	Gravel Kg / M <sup>3</sup>	RHA Kg / M <sup>3</sup>	MK Kg/ M <sup>3</sup>	SP (Liter /100 Kg cement)	Water / powder
SCC( 0% RHA)	450	750	770	0	0	2	0.45
SCC(5%RHA)	427.5	750	770	22.5	0	2	0.45
SCC(10%RHA)	405	750	770	45	0	2	0.45
SCC(15%RHA)	328.5	750	770	67.5	0	2	0.45
SCC (15%MK)	328.5	750	770	0	67.5	2	0.45

**Table ( 9 ) : Results of workability tests of SCC mixes**

Workability test	Unit	Mix designation					EFNAR C SCC limits
		SCC(0% RHA)	SCC(5 %RH A)	SCC(10 %RHA)	SCC(15 %RHA)	SCC(1 5%M K)	
Slump - fiow	mm	790	780	755	735	740	600 - 900
L . box	(H <sub>2</sub> / H <sub>1</sub> )	0.97	0.97	0.94	0.92	0.92	0.8 - 1
V- funal	Sec	6	6.5	7	7.5	7.5	6 - 12

**Table (10 ) : Results of compressive strength of SCC mixes**

Mix designation	Compressive strength MPa			
	7 days	28 days	60 days	90 days
SCC ( 0% RHA)	29.5	42	49	52
SCC ( 5% RHA)	27.5	41	50	54
SCC ( 10% RHA)	25.5	40	51	55.5
SCC ( 15% RHA)	24.0	39	52.5	57
SCC( 15% MK)	32.0	46	55	59

**Table ( 11 ) : Results of flexural strength of SCC mixes**

Mix designation	Flexural strength MPa		
	28 days	60 days	90 days
SCC( 0% RHA)	5.8	6.5	6.95
SCC( 5% RHA)	5.6	6.6	7.25
SCC( 10% RHA)	5.4	6.7	7.45
SCC( 15% RHA)	5.1	6.8	7.8
SCC ( 15% MK)	6.3	7.6	8.1

**Table (12 ) : Modulus of elasticity of SCC mixes**

Mix designation	Modulus of elasticity GPa	
	28 days	60 days
SCC ( 0% RHA)	33.5	34.75
SCC ( 5% RHA)	33.3	34.85
SCC ( 10% RHA)	33.12	35
SCC ( 15% RHA)	33.0	35.1
SCC ( 15%MK)	34.2	36.2

**Table ( 13 ) : Results of water absorption of SCC mixes**

Mix designation	Water Absorption( %) at 28 days
SCC(0% RHA)	3.3
SCC ( 5% RHA)	2.9
SCC ( 10% RHA)	2.7
SCC ( 15%RHA)	2.5
SCC ( 15 % MK)	2.6

**Table( 14 ) : Results of U.P.V of SCC mixes**

Mix designation	U .P .V ( km / sec)	
	28 days	60 days
SCC ( 0%RHA)	4.33	4.48
SCC ( 5% RHA)	4.38	4.55
SCC(10% RHA)	4.43	4.59
SCC( 15%RHA)	4.47	4.63
SCC ( 15 % MK)	4.49	4.70

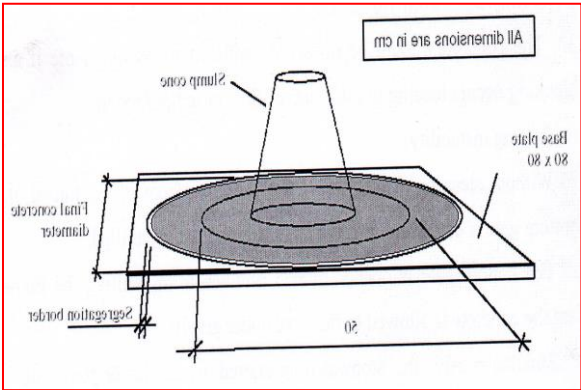
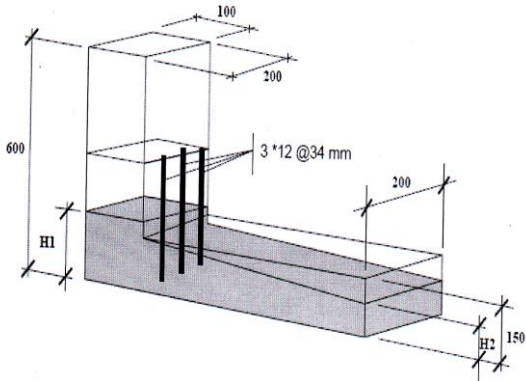

Fig ( 1 ) : Slump – flow



Fig( 2 ) : L – box test

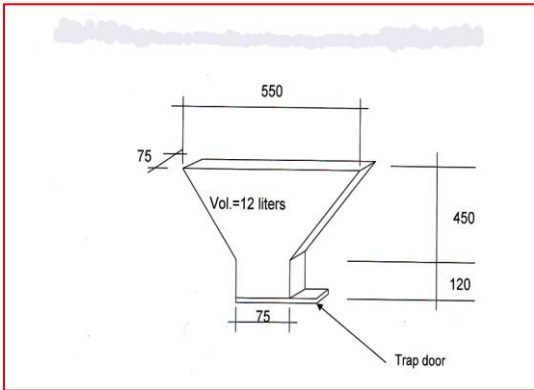

Fig ( 3 ): V- funnel test

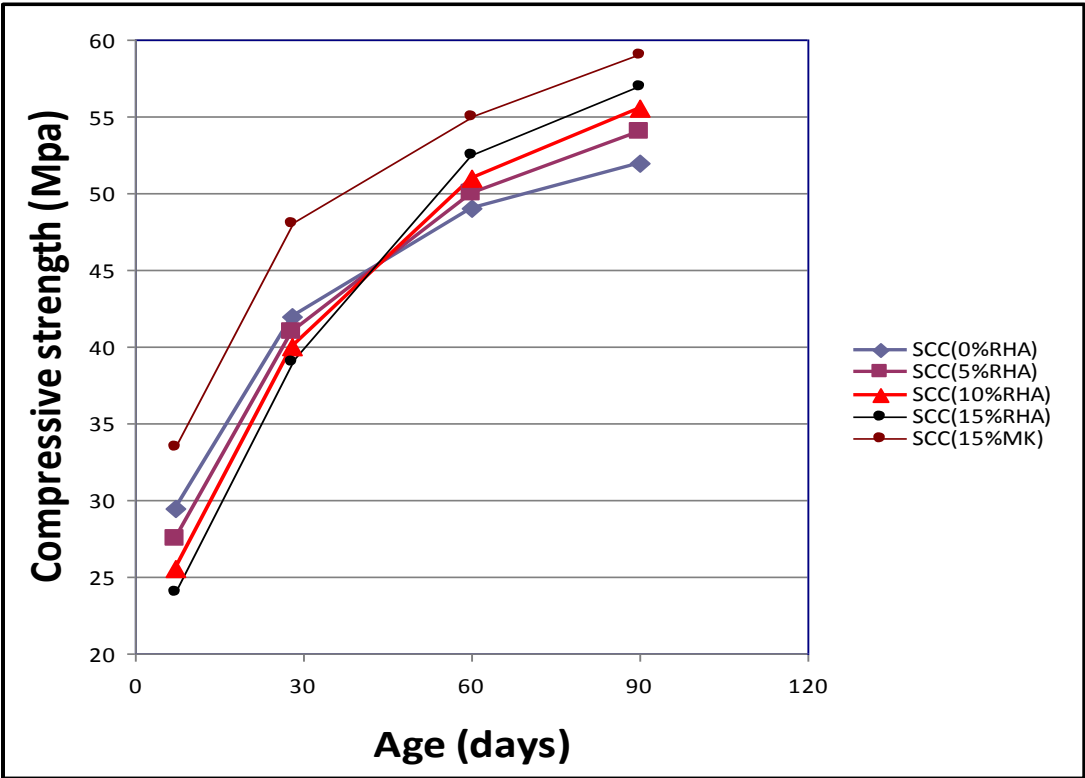

Fig ( 4 ) : Compressive strength development of SCC mixes

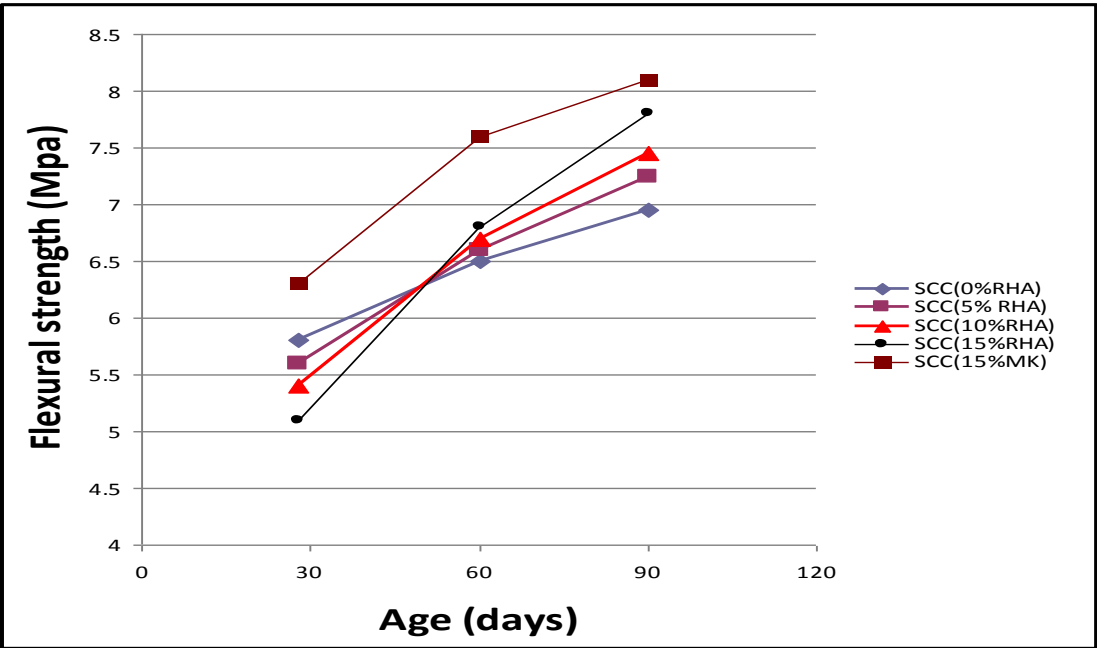
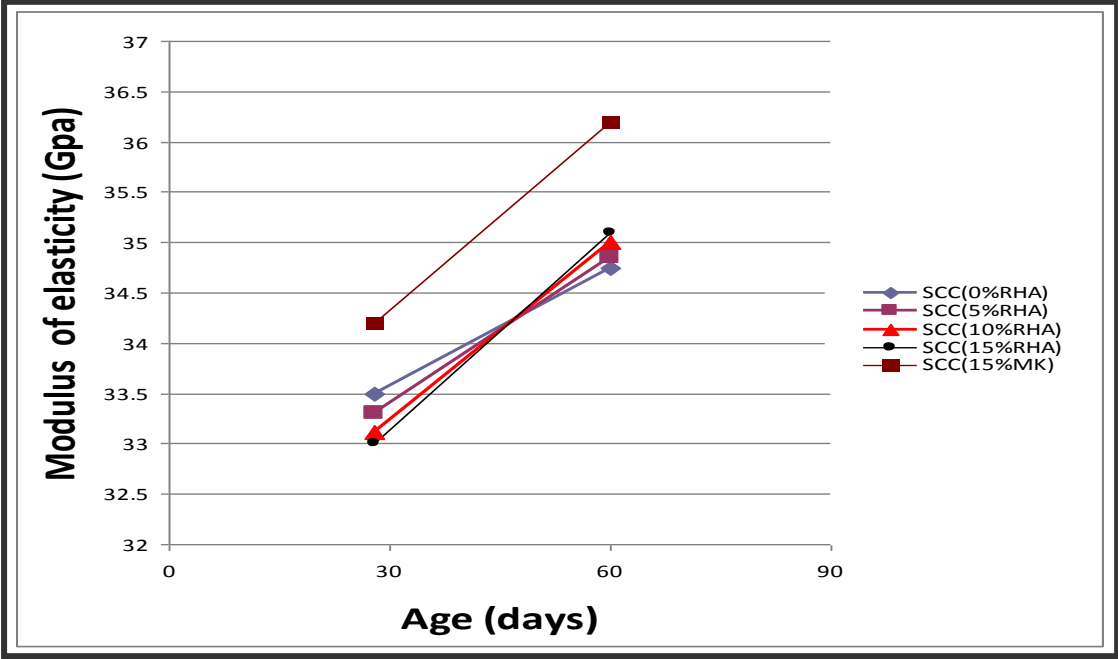

Fig ( 5 ):Flexural strength development of SCC mixes



Fig(6 ):Modulus of elasticity development of SCC mixes