



Comparative study of electrochemical oxidation system hybrid with photocatalytic system for the treatment of Al-Najaf petroleum refinery wastewater

¹Husham M. Al-Tameemi *, ² Khalid A. Sukkar, ³ Ali H. Abbar

¹Chemical Engineering Department, University of Al-Qadissiyah, Iraq

²Chemical Engineering Department, University of Technology- Iraq, Baghdad, Iraq

³Department of Biochemical Engineering, Al-Khwarizmi College of Engineering, University of Baghdad, Baghdad, 10071, Iraq

Article information

Article history:

Received: January, 23, 2024

Accepted: March, 17, 2024

Available online: April, 08, 2024

Keywords:

Petroleum refinery;

Wastewater;

Photocatalytic reaction;

Nanocatalysts;

COD removal

Abstract

In this work, the efficiencies of two combined anodic oxidation with photocatalytic processes (AO + UV/SnO₂ and AO + UV/TiO₂) for treating petroleum refinery wastewater were evaluated and compared based on the COD removal efficiency and energy consumption. Results revealed that increasing the pH and dosage of catalyst has an adverse effect on the removal of COD regarding to AO + UV/SnO₂. The combined process using TiO₂ was better than the combined process using SnO₂ or the process of photocatalytic using SnO₂ alone. At pH 3, a dosage of SnO₂ catalyst of 0.1g/L was needed to achieve a significant removal of COD (80.16%) during 150 min in which a specific energy consumption of 36.54kWh/m³ was required regarding to AO + UV/SnO₂ while using AO + UV/TiO₂ gave better result in terms of removal (89.03%) at lower energy consumption (27.38 kWh/m³). This is an indication that TiO₂ has better photocatalytic efficiency than SnO₂. However, SnO₂ considered as a more environment ecofriendly catalyst with possibility of reaching 90% removal in two cycle process

*Corresponding Author:

Husham M. Al-Tameemi

hmmt_2005@yahoo.com

1. Introduction

Treatment of petroleum refinery wastewaters (PRWs) is the main issue that cause developing many technologies to reduce hazardous contaminants in the wastewater. Petroleum refineries are major consumers of water because the refining process composed of many treatment steps categorized as separation and conversion stages. The size and contaminant composition of the refinery wastewater depends on the size of the refinery and configuration of the process [1]. Wastewater from oil refineries is classified as dangerous industrial waste because it contains toxic components such as phenols, hydrocarbons, and heavy metals [2]. These toxic materials have negative impacts on the aquatic life and plant in addition to sources of surface and groundwater [3]. Petroleum refineries have put great effort into treating wastewater, which can be a hard work due to the complexity of its chemical composition, poor biodegradability, and high toxicity [4]. Many processes can be used to treat wastewater in oil refineries such as treatment by biological approach [5], using membrane filtration systems [6], and application of coagulation/flocculation [7]. Biological processes are the most of them that widely used as a result of their low cost and good efficiency [5]. However, this approach is universally ineffective to remove recalcitrant and persistent pollutants which go through traditional treatment units without being satisfactorily eliminated [8]. Accordingly, the treated effluents from biological systems do not occasionally match the standard limits for reusing or discharging into the environment. Therefore, upgrading and developing new advanced approaches are mandatory to protect the environment. In this context, electrochemical systems such as electrocoagulation (EC) and electrooxidation (EO) were studied extensively and succeeded in treatment of PRWs [9-12]

During the EO process, removal of contaminants is a complex rout and can be involved two mechanisms: direct and indirect oxidation routs. The first consists of direct oxidation of contaminants by adsorbed $\text{OH}\cdot$ while, indirect oxidation is proceeded by chloride ions, which are inhibitory agents in other methods such as biological systems [13]. Boron-doped diamond (BDD) electrodes are applied extensively at in the EO process in spite of its high cost and are considered the strongest electrodes for processing PRWs [14]. Meanwhile, Tin oxide (SnO_2) is one of potential anodic materials that has been used successfully in Li-ion battery [15] as well as in other applications such as solar cells [16], catalysts [17], and gas sensor [18]. In the field of wastewater applications, different SnO_2 -based anodes have been used in the anodic oxidation of numerous kinds of wastewaters and organic materials such as textile, landfill leachate, phenol, nitrophenols, and glucose [19]. However, the consumption of electrical energy as the main part of the overall cost were very high if EO is utilized as a single treatment technology [20]

Photocatalysis is one of the clean technologies that holds a lot of promise in treatment of wastewater. Papers in the field of photocatalytic processes have been increased markedly since the first publication on using titanium dioxide (TiO_2) at 1971[21]. Photocatalysis is one of advanced oxidation processes that uses semiconducting elements or compounds as reusable catalysts have capability to mineralize contaminants using light energy as a main source. Therefore, photocatalysis offers an attractive approach for municipal and industrial wastewaters treatment [22,23]. The most adaptable semiconductor for using as a photocatalyst is TiO_2 due to its non-toxicity property, good photostability, and low cost as well as its exclusive non-selective properties for redox reactions. It has a chemical stability, mechanical strength, high redox potentials (about +3.2 V), and high-energy UV radiation that make it a good photocatalyst applied for numerous reaction media [24-28]. Among the other metal oxide semiconductors that used on photocatalytic process in addition to TiO_2 , SnO_2 has been widely used in many applications as a result of its outstanding optical properties, good chemical stability and excellent electrical properties. It has been used as electrode materials for Li/ SnO_2 batteries in addition to manufacturing dye-sensitized solar cells, optoelectronic devices, and gas sensors. Besides it was used as a photocatalyst for degrading dyes and organic compounds, [29-31]. The SnO_2 structure is classified as a semiconducting material with a wide band gap (e.g. + 3.6 eV) and shows good photocatalytic activity in the presence of ultraviolet light irradiation [32,33]. Compared with TiO_2 , SnO_2 has a similar structure, chemical stability, and band gap. Furthermore, SnO_2 has no opposing health impacts and its absorption by the human body is poor in the case of inhalation or injection [34,35]. SnO_2 nanoparticles are anticipated to show large photocatalytic activity as a result of their large surface areas [36].

Hybrid electrochemical methods are composed from a combination of processes such as electrocoagulation (EC), electrooxidation (EO), and electroflotation along with other treat systems such as ozonation, photocatalysis, ultrasonication, and other advanced oxidation processes [9,10]. However, using a combined process composed from photocatalytic oxidation with anodic oxidation for treating petroleum refinery wastewater was not investigated thoroughly and few papers regarding this combined process for treating other wastewaters were published [37, 38]. Specifically, combining anodic with SnO₂ anode and photocatalytic with SnO₂ nanoparticles has not investigated previously.

The aim of present work is to use a combined process composed of anodic oxidation with SnO₂ anode and photocatalytic process with SnO₂ nano-catalyst for treating petroleum refinery wastewater where effect of pH and SnO₂ dosage on the removal of COD was investigated then a comparison between the combined process using SnO₂ nano-catalyst with the single process (UV/SnO₂) as well as with the corresponding combined process using TiO₂ nano-catalyst to know which process gives the best performance at a low cost.

2. Materials and methods

2.1. Characteristics of petroleum refinery effluents

The case study in this work was an effluent water generated from Najaf refinery plant located in Iraq, where 40 liters were pulled from the feeding vessel before entering the unit of the biological treatment and kept at 4°C during the experimental program. To reduce the suspended solids, present in the effluent, a filtration step was performed using Puchner filter with Whatman filter paper (grade 1) having a pore size of 11 µm. Table 1 displays the features of the treated water by the biological unit in comparison with the untreated wastewater as provided by the plant administration.

Table 1: Characterization of wastewater discharged from Al-Najaf refinery plant.

Characteristic	Inlet	Outlet
pH	7.2	7
Temperature, °C	12	10
BOD, mg/L	180	20
COD, mg/L	857	94
TDS, mg/L	5560	4897
Phenol, mg/L	18.5	0.08
Oil content, mg/L	74.8	57.5
Turbidity, NTU	113	2.47
PO ₄ ³⁻ , mg/L	0.12	0.8
Cl ⁻ , mg/L	900	450

2.2 .Chemicals

Tin oxide (SnO₂) Nano-particles (purity 99.5%, APS 35-55 nm) was utilized as a catalyst for photodegradation which supplied from (NANOSHELL LLC, USA), Nano-particles of Titanium Dioxide (TiO₂) having particle sizes in the range of 10-30 nm (Anatase type, purity 99.5%,) was utilized as a photocatalyst. It was obtained from (SkySpring Nanomaterials Inc, Houston, USA), Tin (II) Chloride dihydrate (Sn Cl₂.2H₂O) with a purity of 98 % purchase from Sigma - Aldrich, USA was used as a source of stannous ions. Nitric Acid with a concentration of (69– 71 %) purchased from FINE CHEM LIMITED, India was used as a source of OH⁻. Ethanol, and acetone were purchased from Aldrich and used for cleaning of copper cathode. Sodium hydroxide (NaOH) (97.5 % Thomas Baker, India) was utilized to regulate pH value to base effect, Hydrochloric Acid (HCl)

(37– 38 % , TEDIA COMPANY, INC) was used to adjust the pH value to an acid effect , Sodium chloride (NaCl) (99.5%, THOMAS BAKER, India) was used to increase the conductivity of solution.

2.3 .The photo-electrochemical system

The experimental work was composed of two stages, the first is preparation of SnO₂ anode based on the method in work of Chang, et al.,2002 [39]. While in the second stage, treatment of wastewater in a combine process was performed. In the first stage, Copper rode with an outside diameter of 20 mm and a length of 80 mm was used as a substrate. It was cleaned sequentially by immersing it in a diluted hydrochloric acid solution (0.1M) for 10 min followed by acetone to remove oxides layer then cleaned by a distilled water before starting the SnO₂ electrodeposition. 750 mL of a plating solution containing 25 mM of Sn Cl₂.2H₂O and 125mM HNO₃ was put inside 1L beaker and agitated at 300 rpm with heating up to 85°C via a hot plate magnetic stirrer (MTOP MS300HS). Air was then blown into the solution for a period of 60 min for oxidizing Sn²⁺ to Sn⁴⁺. In the SnO₂ electrodeposition, copper rode was used as a cathode and a hollow cylindrical graphite (100 mm outside diameter and 80 mm inside diameter with 100 mm length) was used as an anode. A current density of 10 mA/cm² was applied for a period of 30 min via a digital power supply type UNI-T (UTP1305, Hong Kong). At the end of the cathodic deposition, SnO₂ - copper rode was rinsed with water to remove remaining chloride impurity and finely dried at room temperature.

The application of the combined process was based on using a photo-electrochemical system. It was composed from mainly an electrochemical reactor which is tubular in its configuration and operated in a batch-recycling mode with a photocatalytic reactor as depicted in Figure 1. The electrochemical cell was composed of a cell body having dimensions (130 mm outside diameter and 90 mm length) with a cover having dimensions (130 mm outside diameter and 10 mm thickness) both of them made from Perspex. The cell body has an inlet located at the lateral surface with a diameter of 5 mm. A flange provided with four holes was attached to the top of cell body for fixing the body with the cover. The cover was provided with two holes the first was located at the center with a diameter of 10 mm used for fixing the anode while the second was located on the cover away from the center with a distance of 40 mm has a diameter of 10 mm and used as an outlet. The cover has four holes for fixing it with the cell body via four bolts and nuts. The electrochemical cell used in this work is based on concentric electrodes arrangement which gives uniform current and potential distributions. The cathode was 316L stainless steel hallow cylinder. It has dimensions (70 mm outside diameter and 80 mm length) and was fixed inside the cell body by bolt and nut positioned at the center of its length. The anode was the prepared SnO₂ /Cu rode. A suitable current density was applied across the electrodes via a digital power supply type UNI-T (UTP1305, Hong Kong). The photoreactor was 1.5 liters Perspex glass tank with dimensions (150 mm × 110 mm) provided with cover from the same material. It has two outlets located at the bottom; the first is for discharging the treated water having a diameter of 10 mm while the second has diameter of 10 mm and used for circulating the treated water with the electrochemical cell via a recirculation pump type: GRANDFAR: X15GR-10. The cover of photoreactor has dimensions (140 mm outside diameter and 10 mm thickness) and contains four holes. Two holes with a diameter of 10 mm used for inserting the house of UV lumps. The third has a diameter of 30 mm and used for receiving the wastewater from the electrochemical reactor while the last one used for inserting the air provided from an air compressor (HAILEAACO-318). The flow of wastewater was fixed at 4 L/min using a flow meter type: Z-3001T, YYZX Co., China.

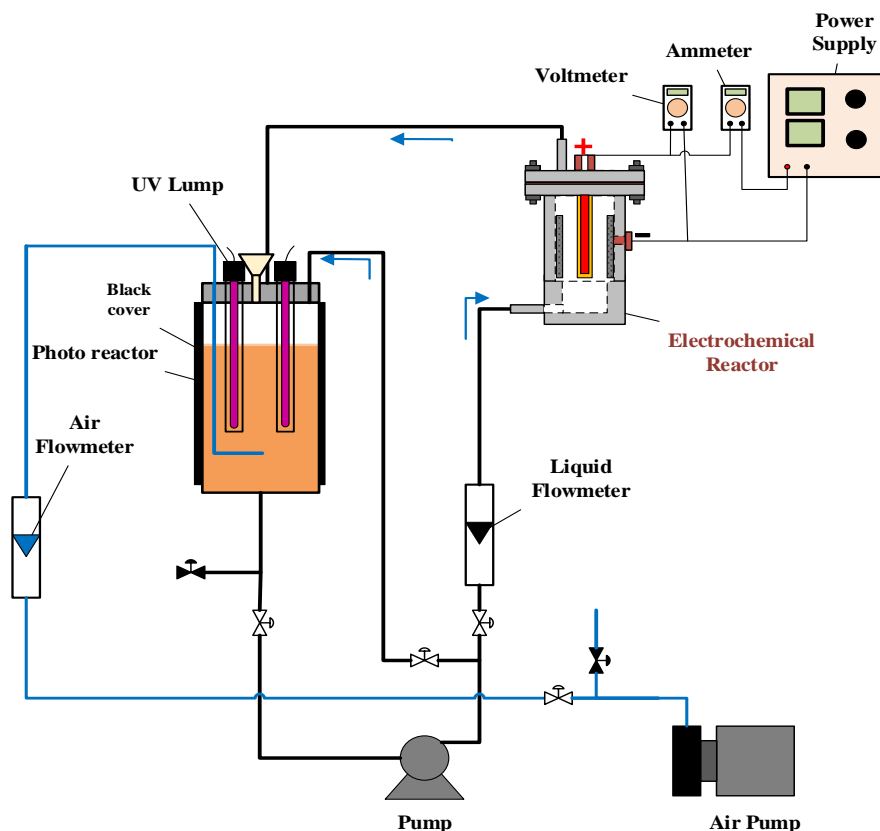

Figure 1: The wastewater treatment system of photocatalysis-anodic oxidation process.

The experimental procedure is started with preparation the solution by taken 1.5 liter of wastewater and adding the required amount of NaCl and catalyst then mixing the solution for 30 min at dark condition to insure dissolving the salt adsorption the contaminants on the surface of catalyst then the solution was transferred to the photoreactor and starting the circulation of the solution between the electrochemical cell and photoreactor using a centrifugal pump. air was provided to the photoreactor at a flow rate of 3L/min via the air compressor. A current density of 12 mA/cm² was applied for a period of 150 min. In this study, the values of pH and dose of catalyst of SnO₂ was varied between two limits based on the previous studies in this field [9-12].

2.4. Analytical Methods

In wastewater treatment, COD was used as an accurate method for determining the constituents of wastewater (organic and inorganic compounds). This test has the ability to measure the level of these compounds according to the quantity of oxygen that totally needed for oxidizing them and converting them to CO₂ and H₂O. In the present work, removal of COD was taken as a response for validating the hybrid process and its capability for incinerating organic pollutants in wastewater from petroleum refineries. The test is based on taking 2 ml of effluent and digesting it with an oxidizing agent (K₂Cr₂O₇) after putting it in a thermal reactor (RD125, Lovibond) for 120 min at 150 °C. The sample was cooled to ambient temperature and test by a spectrophotometer (MD200, Lovibond) to find the COD value. A conductivity tester (HANNA Instrument Inc. Romania) was used for measuring the solution conductivity while a digital pH meter (HANNA Instrument Inc. Romania) was used for measuring the pH of solution.

2.5 Performance evaluation

The performance of the combined process was identified by calculating the efficiency of COD removing based on Eq.1 [40]:

$$RE\% = \frac{COD_i - COD_f}{COD_i} \times 100 \tag{1}$$

In this equation, COD_i , COD_f are the initial and final values of COD in (mg/L) respectively, while RE% denotes the COD removal efficiency

At the advanced oxidation processes such as EO and photo-catalyst process, electrical energy consumption is the major economic factor that indicates the successful of a process. In the present work, calculating the electrical energy consumption in the process of photo-catalyst is based on the proposal of the Photochemistry Commission of the International Union of Pure and Applied Chemistry (IUPAC). It was termed as EEC_1 based on Eq.2 [41]:

$$EEC_1 = \frac{P \times t \times 1000}{V \times \log\left(\frac{COD_0}{COD_f}\right)} \tag{2}$$

In Eq.2 , P represents the UV lump rated power in kW, V denotes solution volume in liter, and time of reaction denotes by (t) in hour. Hence, the required electrical energy consumption for the photo-catalyst process would be in kWh/m³.

For the EO process, Eq.3 could be adopted for calculating the electrical energy consumption [42]:

$$EEC_2 = \frac{U \times I \times t}{V} \tag{3}$$

In Eq. 3, (U) is the voltage of cell in volt and (I) denotes the applied current in ampere while EEC_2 is the consumed electrical energy at EO (kWh/m³).

As a consequence, the energy consumed for the combined system would be the sum of EEC_2 and EEC_1 termed as a total electrical energy (EEC_T).

3. Results and Discussion

3.1 Effect of pH

Figure 2 displays the impact of pH on the COD removal while Table 2 presents the efficiency of COD removal and electrical energy consumption at various pH.

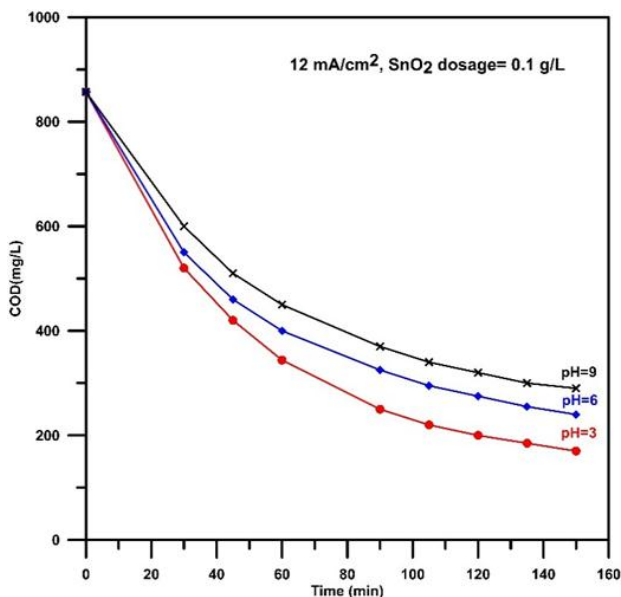

Figure 2: The impact of pH on the removal of COD using AO + UV/SnO₂. 12 mA/cm², 0.1 g/L, 150 min.

Table 2: Impact of pH on the removal of COD using the combined process (AO + UV/SnO₂). 12 mA/cm², 0.1 g/L, 150 min.

pH	COD _f (ppm)	RE%	EEC _T (kWh/m ³)
3	170	80.16	36.54
6	240	71.99	45.7
9	290	66.16	53.3

It was cleared that an increase in pH leads to a decrease in the removal efficiency of COD with an increase in the specific energy consumption. It was stated that the efficiency of contaminants removal by EO would be maximum at certain optimal values of pH that could be acidic. Specifically, this depends on the contaminants chemical structure (i.e., protonated or not protonated, according to pH, consequently enhancing or not enhancing its oxidation) [11]. Besides, OH• concentration and other stable oxidants in the solution are controlled by pH of solution. Ghanim and Hamza, 2018 [43] demonstrated that the initial pH significantly effects on the efficiency of the oxidation process. The authors highlighted that the acidity condition promote the (OH•) activity, leading to the adsorption of organic compounds with a high oxidation rate at the electrode. Moreover, the authors found that a final concentration of COD were 120, 190, and 99 ppm at pH values of 10, 7, and 4, correspondingly. Same results were noted by Duan et al. [44] and Li et al. [45].

Regarding to the effect of pH, SnO₂ may be acidic in nature hence its impact should be taken into account because pH could have impact on the photocatalyst surface by increasing the OH• leading to improve its adsorption [46]. This behavior can be explained as the acidic conditions enhanced the production of H₂O₂ leading to increasing OH⁻ and OH• radicles that react with contaminant leading to increase the degradation of COD, while in basic condition, formation of carbonate ions increases which are scavengers of OH⁻ ions leading to lowering RE% [47]. In petroleum refinery wastewater treatment, Topare et al. [48] found that pH=3 is the best value to get high removal efficiency of COD using TiO₂.

3.2 .Effect of SnO₂ dosage

Figure 3 displays the impact of SnO₂ dosage on COD removal while Table 3 presents the removal efficiency and electrical energy consumption at various SnO₂ dosage.

It was cleared that increasing SnO₂ dosage leads to a decrease in removal efficiency of COD with an increase in the electrical energy consumption. The lowering in RE% beyond 0.1 g/L could be interpreting by the dissipating more UV light from reaching the organics in the solution to the surface of catalyst for oxidizing them [49]. Similarly, Al-Hamdi et al. [46] used three values of catalyst dosage (65,75,100mg/50ml) of SnO₂ or doped SnO₂ and found that 65 mg/50 ml gives better removal for phenol. Same trend was also noted in case of using composite SnO₂-TiO₂ catalyst for degrading phenol [50,51] or TiO₂ in degrading the COD of petroleum refinery wastewater [2,48].

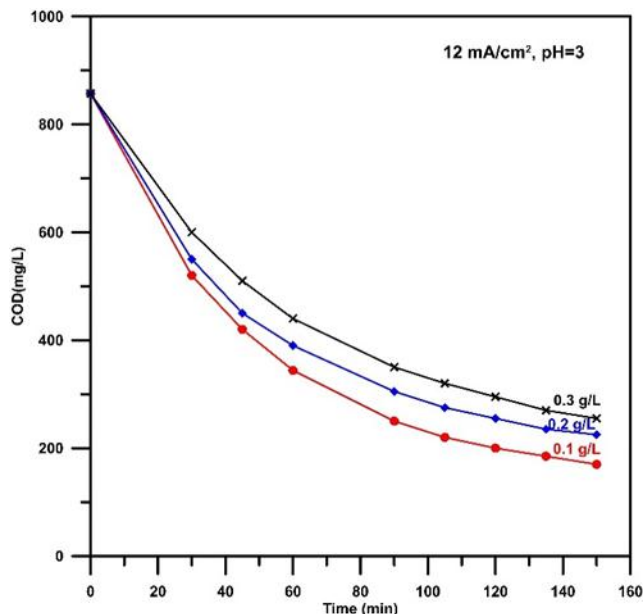

Figure 3: Impact of SnO2 dosage on the removal of COD using AO + UV/SnO2. 12 mA/cm²,pH=3,150 min

Table 3: The impact of SnO2 dosage on the removal of COD using the combined process (AO + UV/SnO2). 12 mA/cm²,pH=3,150 min.

Catalyst dosage (g/L)	COD _f (ppm)	RE%	EEC _T (kWh/m ³)
0.1	170	80.16	36.54
0.2	225	73.74	43.7
0.3	255	70.245	47.97

3.3. Comparison with combined process (AO + UV/TiO2).

Table 4 displays a comparison among AO + UV/SnO2, AO + UV/TiO2, and UV/SnO2 processes. It was cleared that AO + UV/TiO2 has better performance confirming the findings of previous studies. In comparison with UV/SnO2, the combined process gave an enhancement in COD removal from 75.5% to 80.16% with lowering in the energy consumption hence anodic oxidation has a synergetic effect on the photocatalytic process. These are new findings that confirm the possibility of application of AO + UV/SnO2 for treating petroleum refinery wastewater as an ecofriendly process with lower energy consumption in comparison with application this approach for textile wastewater industry [52]. The results of the present work give good removal of COD at a short time. Topare et al. [48] investigated the removal of COD from PRW using TiO2/UV with a maximum removal of 60% from an initial COD of 8200 ppm to a final of 3280 ppm.

Table 4: Comparison between two combined processes (AO + UV/SnO₂) and (AO + UV/TiO₂).

Process	Current density (mA/cm ²)	Catalyst dosage (g/l)	pH	Time (min)	COD _f (ppm)	RE%	EEC _T (kWh/m ³)
UV/SnO ₂	----	0.1	3	150	210	75.5	39.29
Combined process/TiO ₂	12	0.1	3	150	94	89.03	27.38
Combined process/SnO ₂	12	0.1	3	150	170	80.16	36.54

4. Conclusions

A combine photocatalytic with anodic oxidation approach was applied successfully to treat petroleum refinery wastewater. Impact of operating factors such as SnO₂ dosage and pH was studied based on AO + UV/SnO₂. Both pH and SnO₂ dosage has agnostic effect on the removal of COD. An optimal and relatively low dosage of SnO₂ catalyst (0.1g/ L) was needed with initially adjusting the solution pH to 3 for getting a significant removal of COD (80.16%) during 150 min in which a specific energy consumption of 36.54kWh/m³ was required. While using TiO₂ gave better result of 89.03% at lower energy consumption. This is an indication that TiO₂ has better photocatalytic efficiency than SnO₂. However, using SnO₂ has a lower environmental impact in spite of a little increase in the energy consumption.

Acknowledgement: The authors are thankful to the Chemical Engineering Department, University of Technology, Iraq for the scientific support..

References

- [1] Majhool, A. K., Sukkar, K. A., & Alsaffar, M. A., "Combining α -Al₂O₃ packing material and a ZnO nanocatalyst in an ozonized bubble column reactor to increase the phenol degradation from wastewater." *Processes*, 11(8), 2416, 2023.
- [2] Hamied, R. S., Sukkar, K. A., & Raouf, S. R., "Modeling, Kinetic and Experimental optimization of Reforming Unit for Al-Doura Heavy Naphtha over bi and Tri-metallic Catalysts." *Iraqi Journal of Oil and Gas Research (IJOGR)*, 2(1), 108-121., 2022.
- [3] Wake, H., "Oil refineries: a review of their ecological impacts on the aquatic environment." *Estuarine, Coastal and Shelf Science*, 62(1-2), 131-140, 2005.
- [4] Karray, F., "Pilot-scale petroleum refinery wastewaters treatment systems: Performance and microbial communities' analysis." *Process Safety and Environmental Protection*, 141, 73-82, 2020.
- [5] Ebrahimi, M., et al., "An optimized biological approach for treatment of petroleum refinery wastewater." *Journal of environmental chemical engineering*, 4(3), 3401-3408, 2016.
- [6] Santos, B., "Oil refinery hazardous effluents minimization by membrane filtration: An on-site pilot plant study." *Journal of Environmental Management*, 181, 762-769.
- [7] Singh, B., & Kumar, P., "Pre-treatment of petroleum refinery wastewater by coagulation and flocculation using mixed coagulant: Optimization of process parameters using response surface methodology (RSM)." *Journal of water process engineering*, 36, 101317, 2020.
- [8] Vasileva, E., Parvanova-Mancheva, T., & Beschkov, V., "Biological approaches in wastewater treatment." *Journal of Chemical Technology & Metallurgy*, 56(6), 2021.
- [9] Jiad, M. M., & Abbar, A. H., "Efficient Wastewater Treatment in Petroleum Refineries: Hybrid Electro-Fenton and Photocatalysis (UV/ZnO)." *Chemical Engineering Research and Design*.200,431-444, 2023.
- [10] Jiad, M. M., & Abbar, A. H., "Petroleum refinery wastewater treatment using a novel combined electro-Fenton and photocatalytic process." *Journal of Industrial and Engineering Chemistry*,129, 634-655, 2024.

- [1¹] Jawad, S., & Abbar, A. H., "Treatment of petroleum refinery wastewater by electrochemical oxidation using graphite anodes." *Al-Qadisiyah Journal for Engineering Sciences*, 12(3), 144-150, 2019.
- [1²] Abbar, A.H. and Alkurdi, S.S., "February. Performance evaluation of a combined electrocoagulation–electrooxidation process for the treatment of petroleum refinery wastewater". In *IOP Conference Series: Materials Science and Engineering*, 1076, 1, 012027, 2021.
- [1³] Huang, Y. K., Li, S., Wang, C., & Min, J., "Simultaneous removal of COD and NH₃- N in secondary effluent of high- salinity industrial waste- water by electrochemical oxidation." *Journal of Chemical Technology & Biotechnology*, 87(1), 130-136, 2012.
- [1⁴] Souza, R. B. A., & Ruotolo, L. A. M., "Electrochemical treatment of oil refinery effluent using boron-doped diamond anodes." *Journal of Environmental Chemical Engineering*, 1(3), 544-551, 2013.
- [1⁵] Mousa, N. E., et al., "Catalytic photodegradation of cyclic sulfur compounds in a model fuel using a bench-scale falling-film reactor irradiated by a visible light." *Bulletin of Chemical Reaction Engineering & Catalysis*, 17(4), 755-767, 2022.
- [1⁶] Ayllon, J. A., & Lira-Cantu, M., "Application of MEH-PPV/SnO₂ bilayer as hybrid solar cell." *Applied Physics A*, 95, 249-255, 2009.
- [17] Kowal, A., "Synthesis, characterization and electrocatalytic activity for ethanol oxidation of carbon supported Pt, Pt–Rh, Pt–SnO₂ and Pt–Rh–SnO₂ nanoclusters." *Electrochemistry Communications*, 11(4), 724-727, 2009.
- [18] Zhang, T. et al., "Development of microstructure In/Pd-doped SnO₂ sensor for low-level CO detection. *Sensors and Actuators B*", *Chemical*, 139(2), 287-291, 2009.
- [19] Ho, et al., "SnO₂-Mixed Oxide Electrodes for Water Treatment: Role of the Low-Cost Active Anode. In *Cost-efficient Wastewater Treatment Technologies: Engineered Systems Cham*" Springer International Publishing., 255-284, 2022.
- [20] Anglada, A., Ortiz, D., Urtiaga, A. M., & Ortiz, I., "Electrochemical oxidation of landfill leachates at pilot scale: evaluation of energy needs." *Water Science and Technology*, 61(9), 2211-2217, 2010.
- [21] Fujishima, A., & Honda, K., "Electrochemical evidence for the mechanism of the primary stage of photosynthesis." *Bulletin of the chemical society of Japan*, 44(4), 1148-1150, 1971.
- [22] Mondal, K., "Recent advances in the synthesis of metal oxide nanofibers and their environmental remediation applications." *Inventions*, 2(2), 9, 2017.
- [23] Xu, N., et al., "Recent developments in photocatalytic water treatment technology with MXene material: A review." *Chemical Engineering Journal Advances*, 100418, 2022.
- [24] Zhang, B., "Titanium dioxide (TiO₂) mesocrystals: Synthesis, growth mechanisms and photocatalytic properties." *Catalysts*, 9(1), 91, 2019.
- [25] Augugliaro, V., et al., "Overview on oxidation mechanisms of organic compounds by TiO₂ in heterogeneous photocatalysis." *Journal of Photochemistry and Photobiology C: Photochemistry Reviews*, 13(3), 224-245, 2012.
- [26] Lavand, A. B., & Malghe, Y. S., "Visible light photocatalytic degradation of 4-chlorophenol using C/ZnO/CdS nanocomposite." *Journal of Saudi Chemical Society*, 19(5), 471-478, 2015.
- [27] Huang, Z. F., "Tungsten oxides for photocatalysis, electrochemistry, and phototherapy. *Advanced Materials*." 27(36), 5309-5327, 2015.
- [28] Heydari, G., Hollman, J., Achari, G., & Langford, C. H., "Comparative study of four TiO₂-based photocatalysts to degrade 2, 4-D in a semi-passive system." *Water*, 11(3), 621, 2019.
- [29] Sudrajat, H., "Superior photocatalytic activity of polyester fabrics coated with zinc oxide from waste hot dipping zinc." *Journal of Cleaner Production*, 172, 1722-1729, 2018.
- [30] Bhattacharjee, A., Ahmaruzzaman, M., & Sinha, T., "A novel approach for the synthesis of SnO₂ nanoparticles and its application as a catalyst in the reduction and photodegradation of organic compounds." *Spectrochimica Acta Part A: Molecular and Biomolecular Spectroscopy*, 136, 751-760, 2015.
- [31] Shalan, A. E., et al., "An investigation on the properties of SnO₂ nanoparticles synthesized using two different methods." *Journal of Materials Science: Materials in Electronics*, 25, 303-310, 2014.
- [32] Shanian, Z. Y., Abid, M. F., & Sukkar, K. A., "Photodegradation of mefenamic acid from wastewater in a continuous flow solar falling film reactor." *Desalination and Water Treatment*, 210, 22-30, 2021.
- [33] Mendoza-Damián, G., et al., "Photocatalytic properties of boehmite–SnO₂ composites for the degradation of phenol." *Catalysis Today*, 266, 82-89, 2016.

- [34] Sundar, K. P., & Kanmani, S., "Progression of Photocatalytic reactors and it's comparison: A Review." *Chemical Engineering Research and Design*, 154, 135-150, 2020.
- [35] Ani, I. J., et al., "Photocatalytic degradation of pollutants in petroleum refinery wastewater by TiO₂-and ZnO-based photocatalysts: recent development". *Journal of cleaner production*, 205, 930-954, 2018.
- [36] Mousa, N. E., et al., "Catalytic photodegradation of cyclic sulfur compounds in a model fuel using a bench-scale falling-film reactor irradiated by a visible light." *Bulletin of Chemical Reaction Engineering & Catalysis*, 17(4), 755-767, 2022.
- [37] Peralta-Hernández, et al., "Synergism between anodic oxidation with diamond anodes and heterogeneous catalytic photolysis for the treatment of pharmaceutical pollutants." *Sustainable Environment Research*, 26(2), 70-75, 2016.
- [38] Du, T., Zhang, G., & Zou, J., "Coupling photocatalytic and electrocatalytic oxidation towards simultaneous removal of humic acid and ammonia– nitrogen in landscape water." *Chemosphere*, 286, 131717, 2022.
- [39] Chang, S. T., Leu, I. C., & Hon, M. H., "Preparation and characterization of nanostructured tin oxide films by electrochemical deposition." *Electrochemical and solid-state letters*, 5(8), C71, 2002.
- [40] Jiad, M. M., & Abbar, A. H., "Treatment of petroleum refinery wastewater by an innovative electro-Fenton system: Performance and specific energy consumption evaluation." *Case Studies in Chemical and Environmental Engineering*, 8, 100431, 2023.
- [41] Raj, D. V., Ponpandian, N., Mangalaraj, D., & Viswanathan, "Electrodeposition of macroporous SnO₂ thin films and its electrochemical applications." *Materials Focus*, 4(3), 245-251, 2015.
- [42] Baqur, M. S., Hamied, R. S., & Sukkar, K. A., "An Eco-friendly process to produce high-purity nano- γ -Al₂O₃ from aluminum scrap using a novel electrolysis technique for petroleum industry applications." *Arabian Journal for Science and Engineering*, 1-11, 2023.
- [43] Ghanim, A.N. and Hamza, A.S., "Evaluation of direct anodic oxidation process for the treatment of petroleum refinery wastewater." *Journal of Environmental Engineering*, 144(7), 04018047. 2018.
- [44] Duan, X., "Fabrication of a hydrophobic SDBS-PbO₂ anode for electrochemical degradation of nitrobenzene in aqueous solution". *Electrochimica Acta*, 282, 662-671, 2018.
- [45] Li, B., et al., "Selective and nonselective removal of hydrophobic compounds by coupling engineered FeOCl in a cathode-anode synergistic electrochemical platform." *Journal of Hazardous Materials*, p.132148, 2023.
- [46] Al-Hamdi, A., & Sillanpää, M. "Photocatalytic activities of antimony, iodide, and rare earth metals on SnO₂ for the photodegradation of phenol under UV, solar, and visible light irradiations." In *Advanced Water Treatment Elsevier*, 129-288, 2020.
- [47] Kashif, N., & Ouyang, F. "Parameters effect on heterogeneous photocatalysed degradation of phenol in aqueous dispersion of TiO₂." *Journal of Environmental Sciences*, 21(4), 527-533, 2009.
- [48] Topare, N. S., et al., "Treatment of petroleum industry wastewater using TiO₂/UV photocatalytic process". *J. Indian Chem. Soc*, 92, 219-222, 2015.
- [49] Inamdar, A. K., et al., "A review on environmental applications of metal oxide nanoparticles through waste water treatment." *Materials Today: Proceedings*, 2023.
- [50] Cheng, et al., "Photocatalytic restoration of liquid effluent from oil palm agroindustry in Malaysia using tungsten oxides catalyst." *Journal of cleaner production*, 162, 205-219, 2019.
- [51] Zhang, L., et al., "Palygorskite and SnO₂-TiO₂ for the photodegradation of phenol." *Applied clay science*, 51(1-2), 68-73, 2011.
- [52] Santos, L., et al., "Dye degradation enhanced by coupling electrochemical process and heterogeneous photocatalysis." *Journal of the Brazilian Chemical Society*, 26, 1817-1823, 2015.