



Al-Furat Journal of Innovation in Electronics and Computer Engineering (FJIECE) is an international, open access, interdisciplinary, quarterly, and double blind peer-reviewed journal published by Al-Furat Al-Awsat Technical University/Iraq. It is dedicated to the latest advancement in Electronic Engineering, Computer engineering, and their related and subfields.



Dual Bands Microstrip Substrate Integrated Waveguide (SIW) Antenna for K-band Applications

Rand Muwafaq Hadi^{1,2}, Faris Mohammed Ali², Ghufuran M. Hatem²

¹ Najaf Technical Institute, Al-Furat Al-Awsat Technical University, Al-Najaf 31001, Iraq.
E-mail: rand.muaffaq@gmail.com

^{1,2} Communications Eng. Dept., Najaf Technical College, Al-Furat Al-Awsat Technical University, Al-Najaf 31001, Iraq.

E-mail: ghufuranmahdi@etcn.edu.iq

<https://dx.doi.org/10.46649/300320-01>

Abstract— A dual bands circular slot based on a substrate integrated waveguide (SIW) antenna is presented in this paper for K-band applications. The proposed antenna structure is consisting of a microstrip antenna with two circular-shape slots etched on the top of radiation plane and located one on top of the other for bandwidth enhancement. This antenna has been printed on an FR-4 substrate with a dielectric constant 4.3 of and thickness of 1.5 mm. The optimized antenna resonates at 22.45 GHZ and 25GHZ with a fractional bandwidth of 1.20 GHZ about (5.353 %) and 1.50 GHZ about (5.994 %), respectively. The achieved peak gain is about 6.14 dB and 4.72 dB over the operating frequencies, respectively, this makes it suitable for K applications with good matching and return loss characteristics. Design model and performance evaluation of a proposed antenna has been executed by EM simulator, CST Microwave Studio.

Keywords— dual bands, Microstrip, substrate integrated waveguide SIW, K-band.

I. INTRODUCTION

since 1980 the wireless communications rapidly developing as with the first development of the 1G network. To date, Wireless communications have reached a level of the 4G network, which it has been designed to apply the requirements of wireless standards such as LTE-Advanced requirements and IEEE 802.16m [1]. Today, wireless networks and mobile phones could be found anywhere. The speed of transfer data in modern communication has been in a tremendous demand in wireless networks. Because of that, the basic challenges for the developers in developing the future wireless system are the increasing need for higher transmission rates and the growing number of users. For example, the uncompressed high-definition video and image requirement a very high data transmission rate (more than 1Gbps) in wireless transmission.

Due to limited bandwidth, it is difficult to achieve transmission data rate like that because of the traditional wireless systems using frequencies up to 10 GHz [2]. The higher frequencies need conventional waveguide that have very good properties in transmission, the (first generation 1G) of the microwave transmission directorial (guiding) structures is the conventional waveguides, There were advantages of high power handling capacity and high Q factor, but also big that is the drawback of it.

Printed transmission lines are the next generation of microwave guiding elements it is used in Microwave Integrated Circuits (MICs). the advantages of (MICs) is low profile structures but the disadvantage is missing the high capacity to transport power and high Q factor of the traditional waveguides. to overcome these issues between (MIC) structures and traditional waveguides, Substrate Integrated Circuits (SICs) developed that have the advantages of planar low profile structures such as MIC structures, even with high power carrying capacity and high Q factor, such as waveguides [3]. The substrate integrated waveguide (SIW) is one of the techniques of SIC. The SIW technology has been well-applied on the microwave components, include antennas , active circuits and passive components [4]. For microstrip transitions Feasibility of the concept has been proved in [5]. Coplanar waveguide transition also designed in [6][7], Simple waveguide filter and slot antennas have been presented in [8],[9],[10]. The radiation loss generated between gaps of the vias was defined in [11]. Incorporating rectangular waveguide into a microstrip of the substrate reduces the Q-factor of the waveguide because of volume reduction and dielectric filling [6]. SIW proposed good result when it used in antenna structure as we will see next.

In this paper, the substrate integrated waveguide(SIW) technology has been applied to the conservative microstrip

to formed a circular SIW distributions and on the top metallic surface of the antenna two circular slot are etched. The antenna presented two resonates frequencies at 22.4 GHZ and 25.1 GHZ to satisfy the requirement of 5G mobile communication and radar system .

II. MICROSTRIP DESIGN PROCEDURE

To evaluate, the dimensions of microstrip patch antenna as shown in Fig.1.by considering the patch's length is (L_p) and the patch's width is (W_p) [12].

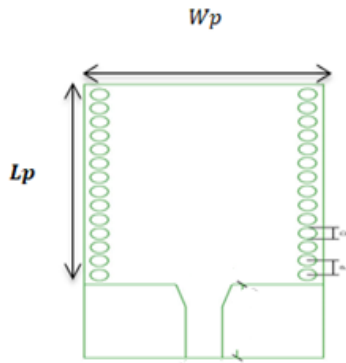

Fig. (1) General design of microstrip patch

Where

$$wp = \frac{c}{2f_o \sqrt{\frac{\epsilon_r + 1}{2}}} \quad (1)$$

$$Lp = L - 2\Delta L \quad (2)$$

Where

$$L = \frac{c}{2f_o \sqrt{\epsilon_{reff}}} \quad (3)$$

C: light velocity in free space.

f_o : the resonates frequency.

ϵ_r : substrate's dielectric constant .

ϵ_{reff} : the efficient permeability.

ΔL : the extended incremental patch's length .

The effective dielectric constant can be calculated as:

$$\epsilon_{reff} = \frac{\epsilon_r + 1}{2} + \frac{\epsilon_r - 1}{2} \left[1 + 12 \frac{h}{wp} \right]^{-\frac{1}{2}} \quad (4)$$

h: thickness of dielectric substrate.

W_p : the width of the patch.

III. SIW CONFIGURATION and DESIGN PROCEDURE

The substrate integrated waveguide (SIW) antenna can be described by row of metallic rods inserted in dielectric substrate between two metallic plates and excited with inset feed as shown in Fig.2.

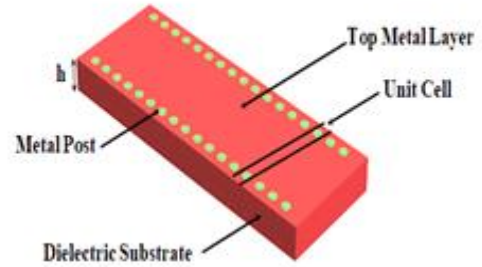

Fig. (2) substrate integrated waveguide

To ensure a minimum leakage between vias gap ($d < \lambda g/5$) and ($p \leq 2d$) the p (pitch: the distance between two vias) and d (the diameter of hole) and (λg : waveguide wavelength) were studied on those issues [14]. The SIW designed by using these conditions to ensure a minimum leakage between the vias gap [13].

In the design of the SIW antenna there are two important parameters must be calculated its (equivalent width a_{eq}) and (equivalent length l_{eff}) as in equations bellow :

$$a_{eq} = asiw - \frac{d^2}{0.95 p} \quad (5)$$

$$l_{eff} = l_{siw} - \frac{d^2}{0.95 p} \quad (6)$$

Where

$asiw$: width between two rows of vias.

l_{siw} : length between two rows of vias.

IV. PROPOSED ANTENNA CONFIGURATION

The proposed SIW antenna structure with total dimensions (15 mmx20 mm) has been designed on FR-4 substrate as a single layer having a relative permittivity of $\epsilon_r = 4.3$, loss tangent of $\delta = 0.025$ and a thickness of $h = 1.5$ mm and it is fed by a microstrip line with impedance of 50Ω . The diameter of metallic via is set to 0.6mm and the pitch between two vias is 1.2mm. The geometry of proposed SIW antenna is shown in Fig. 3 while the overall antenna dimensions are summarized in Table (1).

Fig. (4): The proposed antenna without SIW

The s11 parameter shown in figure below:

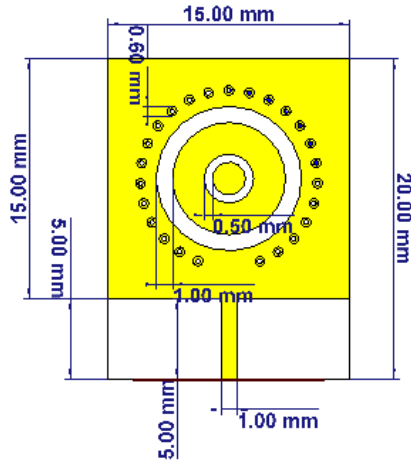

Fig. 3: The geometry of proposed SIW antenna

TABLE I: PARAMETER AND DIMENSION OF SIW ANTENNAS (IN MM).

Symbol	Value	Description
L	20	Total length
W	15	Total width
D	0.6	Via diameter
P	1.2	Pitch between vias
Lms	5	Length of microstrip feed
Wms	1	Width of microstrip feed
Lp	15	Patch length
Wp	15	Patch width
h	1.5	Thickness of substrate
S1	1	outer slot
S2	0.5	Inner slot

V. RESULTS AND DISCUSSION

The first proposed antenna has designed without (SIW) as shown in Fig. (4) to calculate and compare our results. The Simulation results show that it has single band within the sweep frequency of (18-27) GHz with resonant frequency at about 23 GHz as shown in Fig. (5).

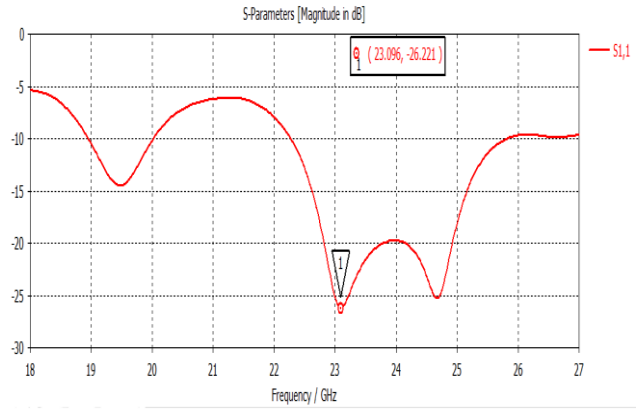
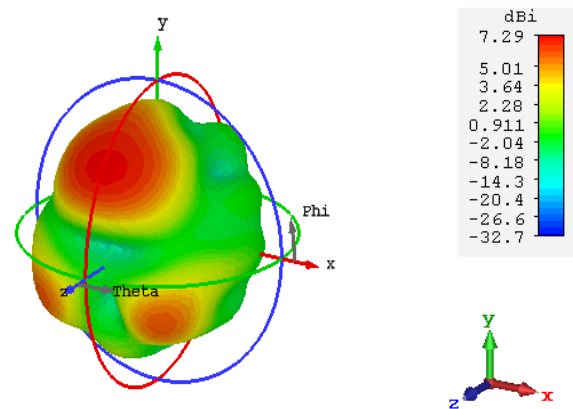
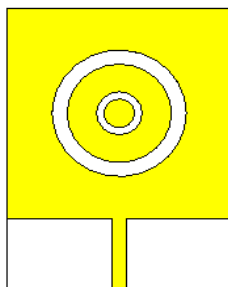

Fig. (5): s11 parameter for the proposed antenna without SIW.

The directivity and peak gain value of the single band have been calculated. In this frequency band, the directivity of the antenna is (7.29 dB) with the peak gain is (3.62 dBi) and the band width is (3.62 GHz) the antenna has low efficiency, The CST simulation of radiation pattern plots for the horizontal plane and the vertical planes respectively, the results show that the antenna almost offers semi-omnidirectional directivity. Fig. (6-a) shows the directivity in 3D and polar form and Fig.(6-b) shows the peak gain 3D and polar.



(a) at F=23 GHz



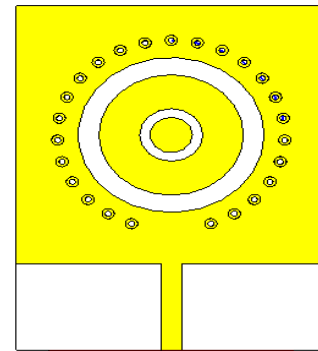
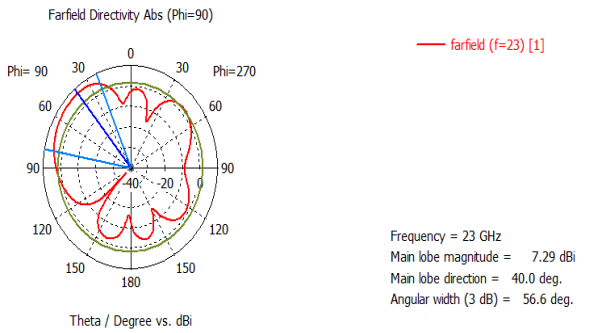
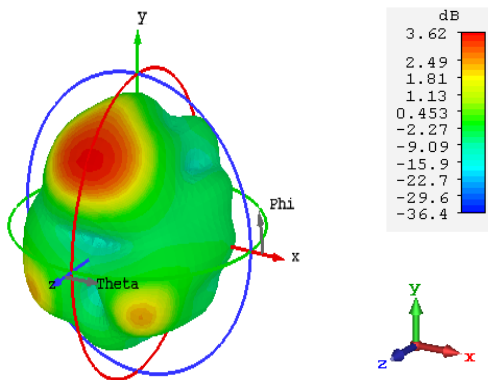

Fig. (7): Proposed antenna with SIW .



(a) at F=23 GHz

The result of S11 response has been presented in Fig. (8). The antenna has dual-band resonant behaviour at 22.45 GHz and 25 GHz with bandwidth (1.20 GHz) for the lower band, and 1.50 GHz for the upper band for return loss ≤ -10 dB respectively. This makes the proposed SIW antenna suitable for the requirement of 5G mobile communication, radar and satellite systems.

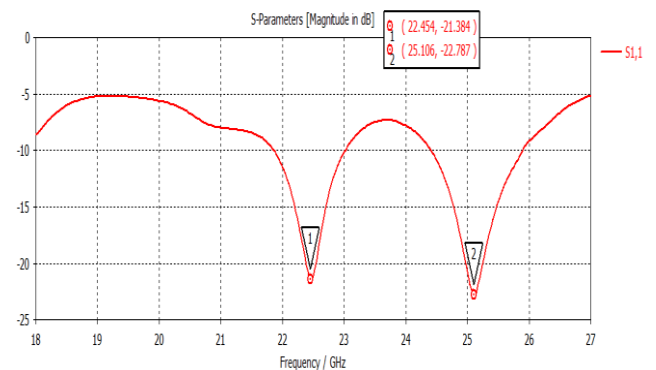

Fig. (8) : The s11 parameter of the SIW antenna

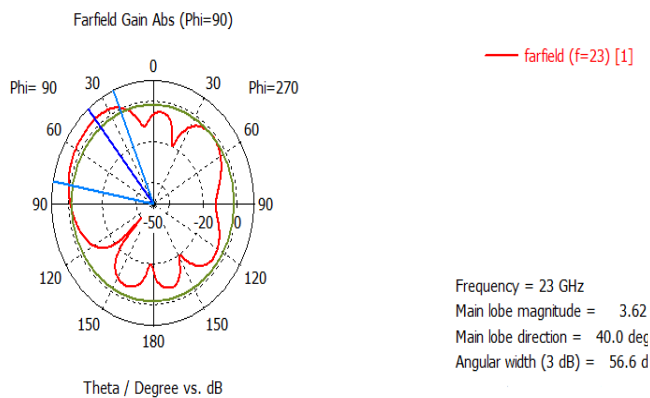
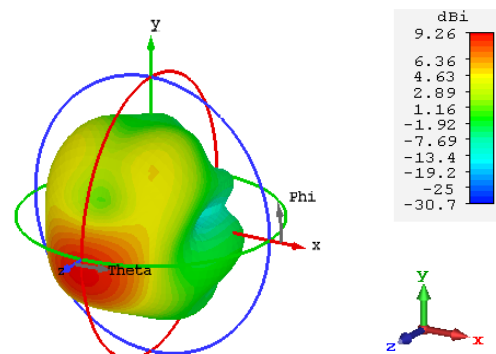

Fig. (6): (a) The directivity (b) gain for the proposed antenna

When SIW technology add to the antenna the result enhanced and give the required that need .The antenna with SIW shown in fig. (7).

The directivity and gain of the first resonant frequency is (9.26 dB and 6.14 dBi), receptivity. As shown in fig. (9) below:



(a) F=22.45 GHz

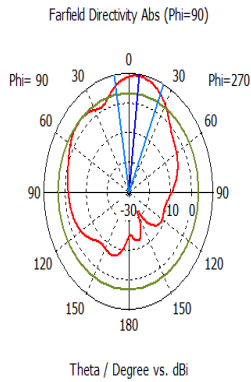

— farfield (f=22.454) [1]

Frequency = 22.454 GHz
 Main lobe magnitude = 9.28 dBi
 Main lobe direction = 7.0 deg.
 Angular width (3 dB) = 34.2 deg.

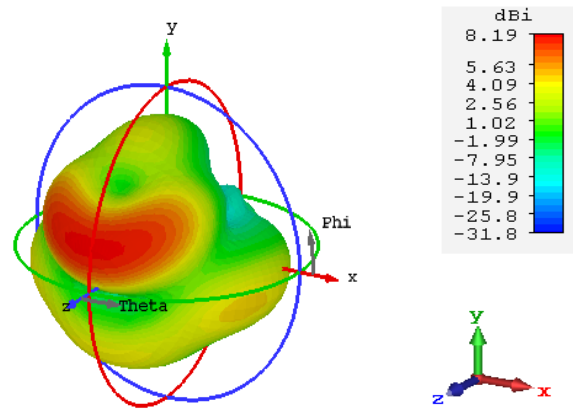

(a) F=25GHZ

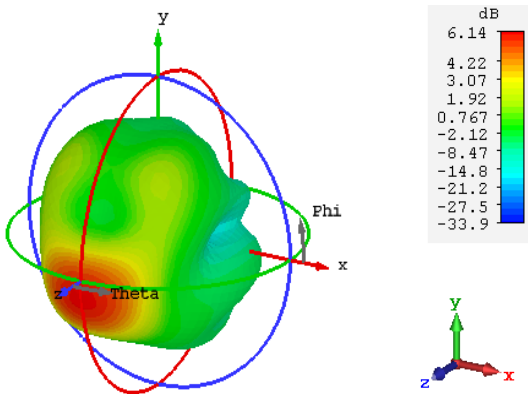

(a) F=22.45 GHZ

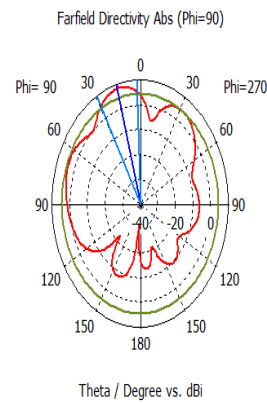

— farfield (f=25.106) [1]

Frequency = 25.106 GHz
 Main lobe magnitude = 8.19 dBi
 Main lobe direction = 16.0 deg.
 Angular width (3 dB) = 26.9 deg.

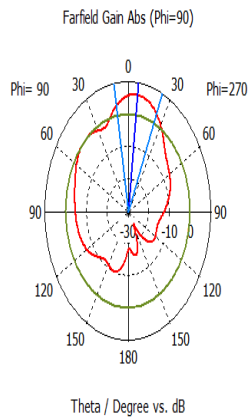

— farfield (f=22.454) [1]

Frequency = 22.454 GHz
 Main lobe magnitude = 6.16 dB
 Main lobe direction = 7.0 deg.
 Angular width (3 dB) = 34.2 deg.

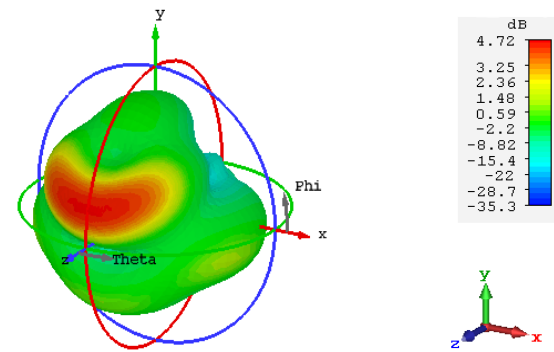

(a) F=25GHZ

Fig. (9): directivity and gain at F=22.45 GHZ.

The result of the second resonant frequency (25 GHZ) the directivity is (8.19 dBi), gain is (4.72 dB). The result of the directivity and gain are shown in fig. (10), below in 3D and polar form:

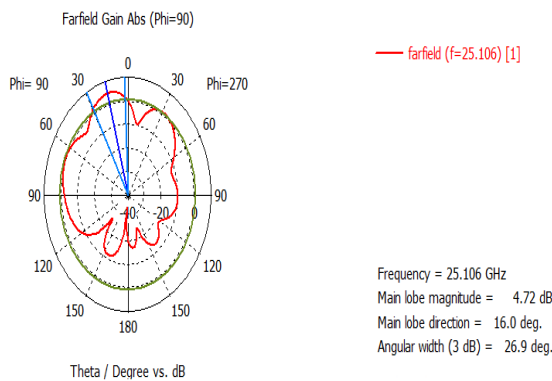

Fig. (10): directivity and gain at F=25 GHZ

From the results seen above the SIW technology make the antenna performance enhanced in the term of matching and this lead to enhanced in the directivity and gain to make antenna suitable for K-band applications requirements.

The current distribution of the proposed antenna at two frequencies are shown in fig. (11) below:

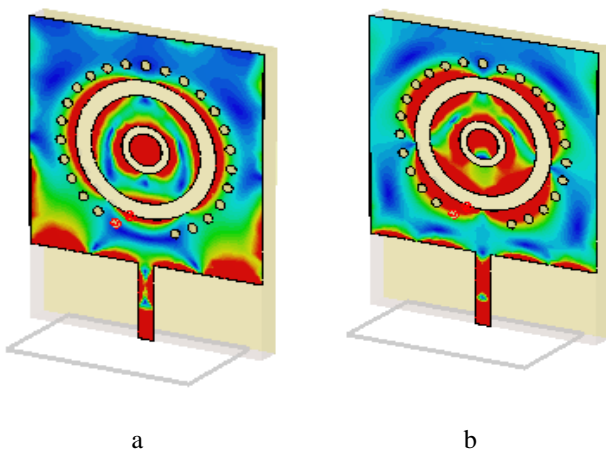

Fig .(10) : (a) current distributions at F=22.45 GHZ .
(b) current distributions at F=25 GHZ .

VI. CONCLUSION

In recent years, means of multimedia communication have been much evolved, in other words, enormous development of the mobile devices industry which has led to the need for providing broadband for these services. But, the available spectrum became crowded and this requires expanding the spectra band and reducing its size. Moreover, the increase in the gain and efficiency of an antenna is counterpoised by higher propagation loss at high frequencies, so the received signal level needs to be higher. A circular slot patch antenna based on SIW structure is proposed in this paper as a candidate for dual-band K-band

applications. The results of the proposed antenna show that when we apply the SIW technique to the design antenna the antenna give better performance for reasonable directivity, gain. This will lead to make this antenna satisfy the requirement of 5G mobile communication, radar and satellite systems.

REFERENCES

- [1] T. S. Rappaport et al, "Millimeter Wave Mobile Communications for 5G Cellular: It Will Work!," in IEEE Access, vol. 1, pp. 335–349, 2013.
- [2] A. Ghosh, et al , "Millimeter-Wave Enhanced Local Area Systems: A High-Data-Rate Approach for Future Wireless Networks," in IEEE Journal on Selected Areas in Communications, vol. 32, no. 6, pp. 1152–1163, June 2014.
- [3] K.WU et al. "Substrate integrated circuits – A new concept for high frequency electronics & optoelectronics". Proc.6th Int.Telecomm. Modern satellite, Cable, broadcast services Conf., 2003, pp 03-10.
- [4] SRIVASTAVA et al. ." Substrate Integrated Waveguide (NFSIW) for Frequency Selective Applications". RE Journal of Communications Antenna and Propagation (IRECAP),. pp. 259-263,2012.
- [5] DESLANDES, D. "Design equations for tapered microstrip-to-substrate integrated waveguide transitions". Microwave Symposium Digest (MTT),. IEEE MTT-S International, 2010. IEEE, 704-707.,2010.
- [6] DESLANDES, D et al., "Integrated microstrip and rectangular waveguide in planar form. Microwave and Wireless Components Letters. IEEE, 11, 68-70. ", 2001.
- [7] DESLANDES, D. et al., "Accurate modeling, wave mechanisms, and design considerations of a substrate integrated waveguide". Microwave Theory and Techniques,. IEEE Transactions on, 54, 2516-2526, 2006.
- [8] A. M. Hamzah et al., "H-Shaped Fractal Slots Based Highly Miniaturized Substrate Integrated Waveguide Metamaterial Bandpass Filters for C-Band Applications," vol. 86, no. March, pp. 139–158, 2020.
- [9] L. Yan et al., "Simulation and experiment on SIW slot array antennas," IEEE Microw. Wirel. Components Lett, pp. 446–448, Sep. 2004, doi: 10.1109/LMWC.2004.832081 , ., vol. 14, no. 9,2004.
- [10] S. Mukherjee et al., "Broadband substrate integrated waveguide cavity-backed bow-tie slot antenna," IEEE Antennas Wirel. Propag. Lett., , doi: 10.1109/LAWP.2014.2330743, vol. 13, no. c, pp. 1152–1155, 2014.
- [11] SAMAH et al., "Study of design consideration and performance analysis of substrate integrated waveguide components". Degree of Master,. Universiti Teknikal Malaysia, Melaka, 2011.
- [12] Balanis et al., "ANTENNA THEORY ANALYSIS AND DESIGN ",1938, "Modern antenna hand book / Constantine A. Balanis. , Published by John Wiley & Sons, Inc., Hoboken, New Jersey., 4th ed.2016.
- [13] T. Djera et al., "Handbook of Antenna Technologies", no. Salmon 2004. 2014.
- [14] K. Wu et al, "The substrate integrated circuits-A new concept for high-frequency electronics and optoelectronics," 6th Int. Conf. Telecommun. Mod. Satell. Cable Broadcast. Serv. TELSISKS 2003 - Proc, doi: 10.1109/TELSKS.2003.1246173, vol. 1, 2003 .