



ISSN: 1813-162X (Print); 2312-7589 (Online)

Tikrit Journal of Engineering Sciences

available online at: <http://www.tj-es.com>
**TJES**  
 Tikrit Journal of  
 Engineering Sciences

# Optimization of Stable Energy PV Systems Using the Internet of Things (IoT)

Yasser Mohammad Al-Sharo <sup>a</sup>, Khalid Al Smadi <sup>b</sup>, Takialddin Al Smadi <sup>c\*</sup>,  
 Yasameen Kamil N. <sup>d</sup>

<sup>a</sup> Faculty of Computer Science and Information Technology, Ajloun National University, Ajloun, Jordan.

<sup>b</sup> Computer Science, Jadara University, Irbid, Jordan.

<sup>c</sup> Faculty of Engineering, Jerash University, Jerash, Jordan.

<sup>d</sup> Electrical Engineering Department, University of Anbar, Anbar, Iraq.

## Keywords:

Energy Management; Internet of Things (IoT); Maximum Power Point Tracking; Optimization; Photovoltaic System.

## Highlights:

- The Internet of Things (IoT) has numerous applications in the energy industry, such as energy generation and integrating renewable energy sources.
- We have undertaken an extensive and analytical investigation of the Internet of Things (IoT) about intelligent energy systems and networks.
- IoT in smart energy applications, IoT in data transmission networks, and IoT in energy production resources are reviewed.
- The study compares IoT sensor-based waste collection methods with traditional methods.

## ARTICLE INFO

### Article history:

Received	03 Oct.	2023
Received in revised form	09 Dec.	2023
Accepted	20 Dec.	2023
Final Proofreading	16 Feb.	2024
Available online	19 Feb.	2024

© THIS IS AN OPEN ACCESS ARTICLE UNDER THE CC BY LICENSE. <http://creativecommons.org/licenses/by/4.0/>



**Citation:** Al-Sharo YM, Al Smadi K, Al Smadi T, Yasameen Kamil N. **Optimization of Stable Energy PV Systems Using the Internet of Things (IoT).** *Tikrit Journal of Engineering Sciences* 2024; 31(1): 127-137.

<http://doi.org/10.25130/tjes.31.1.11>

## \*Corresponding author:

Takialddin Al Smadi

Faculty of Engineering, Jerash University, Jerash, Jordan.



**Abstract:** The modern power grid faces rapid growth in load demand due to industrialization, leading to an unregulated environment and increasing adoption of renewable energy sources, which presents technical challenges, particularly in terms of stability. Hydrogen conversion technology revolutionizes clean electricity storage with renewable energy, and solar hydrogen is now available in autonomous solar systems. The efficiency of solar photovoltaic systems is closely related to using digital electronic maximum peak power tracking (MPPT) technology. The Internet of Things (IoT) is crucial for performance monitoring and real-time control of PV systems, enhancing the understanding of real-time operating parameters. IoT and wireless sensor networks for distributed solar energy devices and joint building design are essential for developing the photovoltaic construction industry. In this paper, the monitoring system that has been proposed offers a potentially effective solution for the intelligent remote and real-time monitoring of solar photovoltaic (PV) systems. It demonstrated a high level of accuracy, reaching 98.49%, and can transmit graphical representations to a smartphone application within a time frame of 52.34 seconds. Consequently, the battery's longevity was extended, energy consumption was diminished, and the quality of service (QoS) for real-time applications inside the Internet of Things (IoT) was enhanced.

# تحسين أنظمة الطاقة الكهروضوئية المستقرة باستخدام إنترنت الأشياء (IoT)

ياسر محمد<sup>١</sup>، خالد الصمادي<sup>٢</sup>، تقي الدين الصمادي<sup>٣</sup>، ياسمين كامل<sup>٤</sup>

<sup>١</sup> كلية علوم الحاسوب وتكنولوجيا المعلومات / جامعة عجلون الوطنية / عجلون - الأردن.  
<sup>٢</sup> كلية الهندسة / جامعة جرش / جرش - الأردن.  
<sup>٣</sup> علوم الحاسوب / جامعة جدارا / إربد - الأردن.  
<sup>٤</sup> قسم الهندسة الكهربائية / جامعة الانبار / الانبار - العراق.

## الخلاصة

تواجه شبكة الطاقة الحديثة نموًا سريعًا في الطلب على الأحمال بسبب التصنيع، مما يؤدي إلى بيئة غير منظمة وزيادة اعتماد مصادر الطاقة المتجددة، مما يمثل تحديات فنية، لا سيما فيما يتعلق بالاستقرار. تُحدث تكنولوجيا تحويل الهيدروجين ثورة في تخزين الكهرباء النظيفة باستخدام الطاقة المتجددة، والهيدروجين الشمسي متوفر الآن في أنظمة الطاقة الشمسية المستقلة. ترتبط كفاءة أنظمة الطاقة الشمسية الكهروضوئية ارتباطًا وثيقًا باستخدام تقنية تتبع الطاقة القصوى لذروة الطاقة الرقمية الإلكترونية (MPPT). يعد إنترنت الأشياء (IoT) أمرًا بالغ الأهمية لمراقبة الأداء والتحكم في الوقت الفعلي للأنظمة الكهروضوئية، مما يعزز فهم معلمات التشغيل في الوقت الفعلي. تعد شبكات إنترنت الأشياء وشبكات الاستشعار اللاسلكية لأجهزة الطاقة الشمسية الموزعة وتصميم المباني المشتركة ضرورية لتطوير صناعة البناء الكهروضوئية. في هذه الورقة، يقدم نظام المراقبة المقترح حلاً فعالاً للمراقبة الذكية عن بعد وفي الوقت الحقيقي لأنظمة الطاقة الشمسية الكهروضوئية. وقد أظهرت مستوى عالٍ من الدقة، وصلت إلى ٩٨,٤٩٪، ويمكنها نقل التمثيلات الرسومية إلى تطبيق الهاتف الذكي خلال إطار زمني قدره ٥٢,٣٤ ثانية. ونتيجة لذلك، تم تمديد عمر البطارية، وتقليل استهلاك الطاقة، وتحسين جودة الخدمة (QoS) للتطبيقات في الوقت الحقيقي داخل إنترنت الأشياء (IoT).

**الكلمات الدالة:** تحسين، موارد الطاقة المتجددة، نظام الضوئية، تتبع أقصى نقطة للطاقة، إدارة الطاقة، نظام تخزين الطاقة، إنترنت الأشياء (IoT).

## 1. INTRODUCTION

Renewable energy PV systems have led to a global transition to 100% renewable electricity generation, necessitating automatic monitoring, analysis, and control of power plants, distribution, and network infrastructure. Information and communication technology devices are needed to address reliability problems and optimize grid loading. Renewable energy sources are highly intermittent, and converters and non-synchronous machines are vital in supporting voltage stability. Many studies have analyzed the impact of non-synchronous devices on voltage stability in traditional grids. The authors in [1-4] proposed a controller to mitigate voltage stability when integrated with large-scale photovoltaic plants, reducing transmission expansion costs. In Al-Agha and Alsmadi [5] the voltage stability assessment with bulk wind energy penetration was studied, while the importance of combining wind energy and FACTS devices at strategic locations was highlighted. The Internet of Things (IoT) is a complex digital and physical infrastructure for intelligent control, power supply systems, and distributed energy consumption [6]. Recent development scenarios aim for 100% renewable energy by 2070, combining distributed renewable energy generation systems with energy storage devices. Photovoltaic power generation has reached parity with fossil energy; however, affordability hinders the transition to 100% renewable energy sources [7,8]. Hydrogen conversion technology has revolutionized clean electricity storage with renewable energy, and the efficiency of solar photovoltaic systems is closely related to using

a power optimizer, such as MPPT. IoT aims to create a vast network for intelligent object management and supervision, utilizing electronic sources to learn about specific topics [9]. The ZigBee Alliance significantly influences IoT applications in smart homes, healthcare, and industrial monitoring [10-12]. Distributed solar energy systems will be used online in the future, enabling intelligent gathering, transmission, and monitoring of operating parameters for distributed solar structures. It is known that changes in solar radiation are linked to solar installations. The apparent sky factor, occlusion index, and spatial coefficient are some indicators that show how the solar output is distributed with time and space. Transportation, industry, and construction are the three industries with the highest energy consumption, reflecting economic development and improving people's quality of life through more efficient energy generation and increased building energy consumption [13].

## 2. LITERATURE REVIEW

Solar energy has the potential to serve as a compelling alternative for energy generation, as a primary and secondary source. Solar energy harvesting feasibility in Palembang has been the subject of a study by [14, 15]. The research findings indicated that Palembang's geographical location enabled attaining optimum power output. However, it is worth noting that utilizing solar energy is more advantageous in remote and highland regions, as demonstrated by [16]. Optimized the output and efficiency of photovoltaic (PV) systems implemented in Palembang; however, despite the possibility of overheated panels in certain

regions of South Sumatra, the disadvantage is negligible compared to the advantages gained from this application. According to Shatnan et al. [17], environmental conditions can influence the performance and efficiency of solar panels; therefore, adjusting the panel to those conditions, such as by implementing MPPT, can help surmount these obstacles [18, 19]. Given the references, the viability of integrating solar energy systems into hospital settings in Palembang is exceptionally high [20]. Discuss the viability of implementing a PV system utilizing the RSM and ANFIS methodologies; notwithstanding the extensive implementation of Internet of Things (IoT) systems within intelligent greenhouses, the method by which this technology can optimize greenhouse environments, particularly in tropical regions prone to extreme temperature fluctuations, remains inadequately understood. Developed nations have been the primary locations for research and development due to their direct access to IoT resources and systems.

Furthermore, the current knowledge regarding implementing IoT systems in intelligent greenhouses in tropical regions is inadequate [21].

### 2.1. The Sustainable Energy IoT

Adopting sustainable technology is crucial for global energy access, as it improves the operation and performance of current power systems. Technology-based applications can create reliable, affordable energy access, satisfying the community's energy needs. IoT technology effectively provides cheap energy and connects supply chains and components of sustainable energy systems [22, 23]. This paradigm combines human resources and cutting-edge technologies to meet future energy needs and barriers. The IoT's capability to develop future energy systems links innovative technologies and solutions globally. In the long run, IoT for energy has the potential to achieve the sustainability and resilience of current energy infrastructure while also lowering future energy consumption, as shown in Fig. 1.

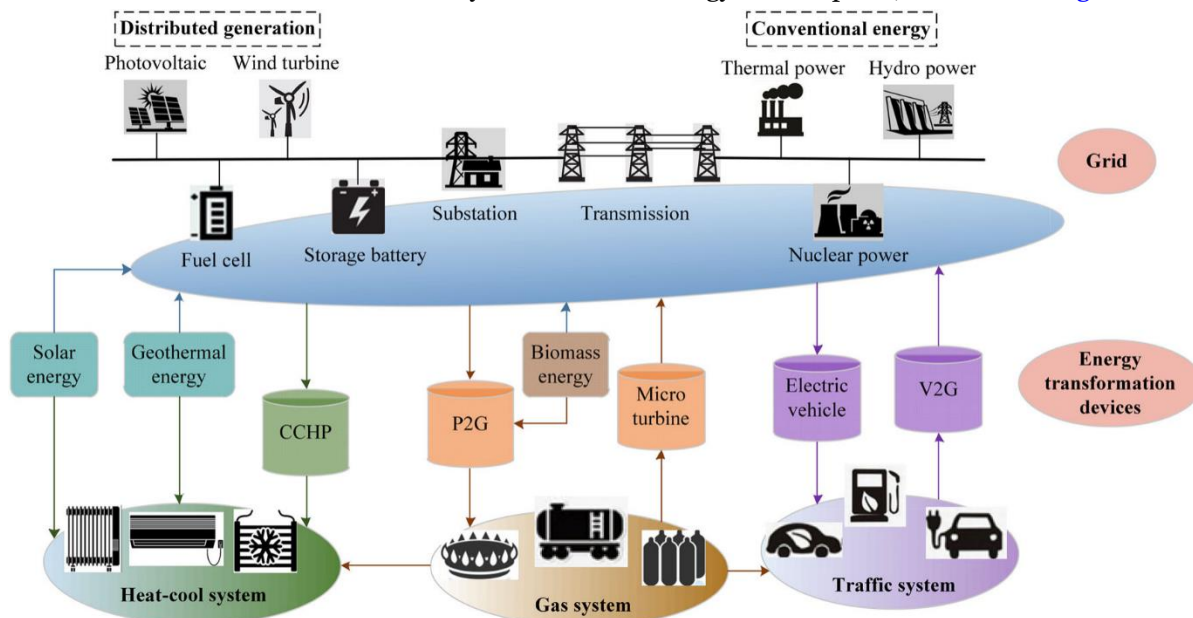

**Fig. 1** Overview of the Sustainable Energy IoT.

IoT in sustainable energy systems offers access to global energy via clean, renewable energy. This technology facilitates safe, cost-effective, and environmentally friendly energy systems, increasing resource usage and lowering energy conservation costs. In Wali and Muhammed [24], Hilme and Abdulkafi [25], four possibilities for decreasing cloud based IoT network traffic power were presented using the MILP optimization model. Developed a multi-objective particle swarm optimization (MOPSO) mechanism for optimizing energy utilization, increasing ROI, and decreasing response time. Leon-Garcia created a heuristic strategy for addressing QoS in cloud-based architectures in IoT service selection. In Ref. [26], combinatorial optimization, non-linear programming, and linear programming are

utilized to tackle diverse optimization problems, while the approximation approaches used in optimization tactics include heuristics and meta-heuristics. There are two types of optimization techniques: exact and approximation methods (heuristics and meta-heuristics methods) [27]. Fig. 1 depicts the optimization approaches classification. Therefore, the fundamental objective of this work is to present a realistic approach that includes increased battery lifetime for IoT nodes, reduced energy consumption, and improved QoS requirements for real-time applications in the IoT.

### 3. METHODS AND DATA ACQUISITION

This work view describes a system measuring a solar PV panel's voltage, current, temperature,

and exposure to sunlight. A wireless transceiver, NodeMCU ESP8266, uploaded data online, while Arduino ATmega2560 recorded it. Think Speak, an open-source IoT cloud platform, stores sensor data and displays it in a graphical format. The system can be monitored using the Think Speak website and a smartphone application [28]. The MPPT solar charge controller was connected to a monocrystalline solar photovoltaic panel with a maximum power output of 100 W, voltage of 18 V, and current of 5.56 A. A 12 V, 7 Ah Valve Regulated Lead Acid battery was used for storage. A voltage divider circuit in Eq. (1) senses the solar PV voltage shown in Fig. 2, where  $V_{in} = 18.30$  V,  $R_1 = 1$  k $\Omega$ , and  $R_2 = 10$  k $\Omega$

$$V_{out} = V_{in} \times \frac{R_2}{R_1 + R_2} \quad (1)$$

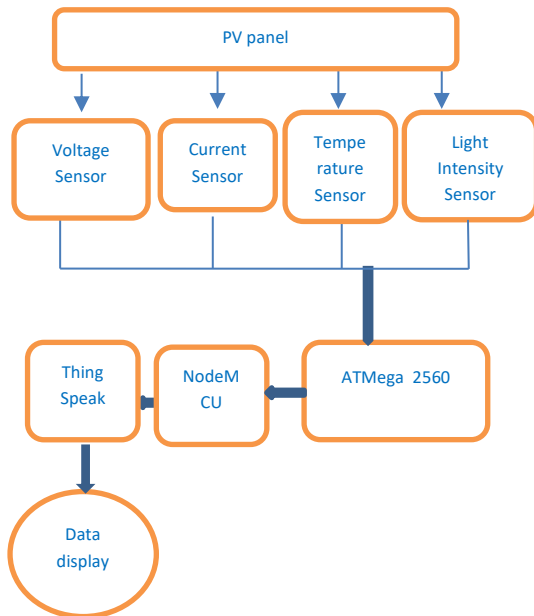

**Fig. 2** Flow Chart of PV Monitoring System Using (IoT).

#### 4. RELATED WORK

Think Speak was employed to store sensor data and present it in a graphical format, enabling users to access the data remotely, provided an internet connection is established. The monitoring process can utilize the Think Speak website and mobile applications developed using MIT. Attaining maximum power transfer (MPT) can be accomplished through the fine adjustment of the wind by a slight deviation in current, resulting in a corresponding change in the voltage value by the slope. Inverters have effectively optimized the power output of individual modules by combining the benefits of single and micro-inverters, which has led to a significant decrease in power losses and a notable improvement in the energy efficiency of photovoltaic (PV) modules, with potential gains of up to 50%. Subsequently, this strategy has been extensively employed [29, 30]. The organization of this paper is as follows: in the

next section, a photovoltaic (PV) energy system is presented. The third section forecasts optimizing energy usage (IoT) and capacity. The fourth section presents the Maximum Power Point Tracking (MPPT) Technique Description. Results and Discussion, followed by the final remarks in the fifth and sixth sections.

#### 4.1. Optimization of Energy Usage (IoT) and Capacity

Think Speak is employed to store sensor data and present it. The application of IoT technology in the energy industry is rapidly growing. It now includes intelligent grid management, electric vehicle control, grid operations, network management, microgrid control, district heating and cooling, demand-side management, demand response, metering infrastructure, smart buildings, battery operations, energy storage, and wind farm operations. Power companies should optimize technology nodes, flash access, energy harvesting, and flexible front ends, integrate important features into digital chips, offer adaptable power mechanisms and energy-saving solutions, and use power-optimized devices to improve network quality to exploit IoTs fully. Only a few electricity firms are now driving these IoT developments [31-33]. The rapid recent progress on the IoT in the energy sector can be observed in smart grid management, electric vehicle control, grid operations, network management, microgrid control, district heating and cooling, demand-side management, demand response, metering infrastructure, smart buildings, battery operations, energy storage, and wind farm operations. To take full advantage of IoTs, power companies should enhance network quality by optimizing technology nodes, optimizing flash access, energy harvesting, flexible front ends, integrating key features into digital chips, offering adaptable power mechanisms, energy-saving solutions, and using power-optimized devices [34]. Optimization of energy usage is a technique that utilizes IoT technology to enhance the efficiency of power systems. (IoT)-enabled sensors collect real-time data on energy consumption patterns, allowing operators to identify high-energy usage areas and develop strategies to reduce consumption. This optimization improves overall efficiency, reduces costs, and minimizes environmental impact [35]. A typical solar vehicle power system consists of a matrix with series-connected photovoltaic cells, a battery pack, and a DC/DC converter. The controller continuously adjusts the converter to maintain the operating voltage of the solar panel according to its Point Tracking System architecture. The maximum power for a solar electric vehicle is shown in Fig. 3.

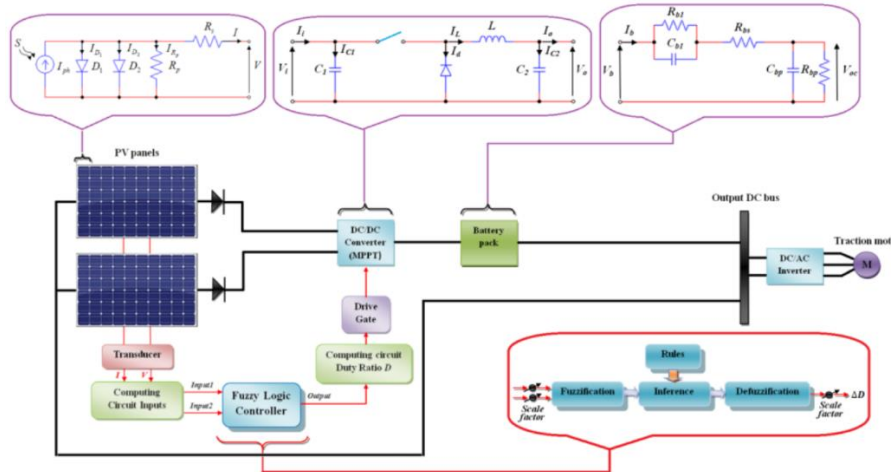

**Fig. 3** OTMM Component Architecture for Solar Electric Vehicle with Fuzzy Controller.

**5. MAXIMUM POWER POINT TRACKING (MPPT) TECHNIQUE DESCRIPTION**

Several techniques track the maximum power point (MPP), such as the incremental conductance technique, fractional OCV technique, fractional SCC technique, neural network technique, and fuzzy logic control [14]. In this study, a fuzzy logic controller (FLC) considered the MPPT technique. The FLC technique maintained the control of the PV system based on a data knowledge process. The stages of the FLC are shown in Fig. 4.

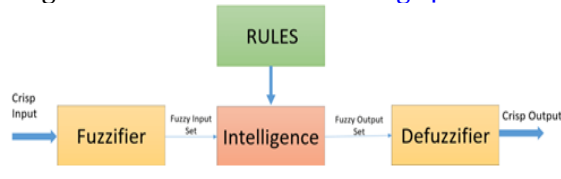
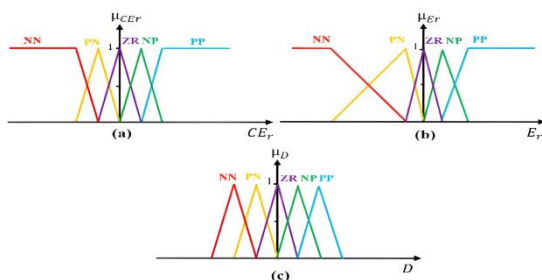

**Fig. 4** The Block Diagram for the FLC Technique [14].

The FLC inputs  $E_r$  and FLC output  $CE_r$  are given as follows.

$$\begin{cases} E_r = \frac{P_{pv}(K) - P_{pv}(K - 1)}{V_{pv}(K) - V_{pv}(K - 1)} \\ CE_r = E(K) - E(K - 1) \end{cases} \quad [14]$$

where  $K$  denotes sample time. The MFs of FLC inputs  $E_r$ , FLC output  $CE_r$ , and duty cycle ( $D$ ) are illustrated in Fig. 5. Each MF involved five fuzzy sets: NN, PN, ZR, NP, and PP (where N and P represent low and high, respectively). Table 1 shows the table of rules [14].



**Fig. 5** Input and Output MFs. Legends: (a):  $\mu_{CE_r}$ , (b):  $\mu_{E_r}$  and (c):  $\mu_D$  [14].

The membership (MF) characterizes the fuzziness of the fuzzy sets. The triangular MFs are widely used due to their simplicity and linearity. They perform well and better than other types of MFs. Different shapes can be obtained from triangle transformations induced by linguistic modifiers, truth-functional modifiers, compositions, projections, and other operations [14]. The power demanded from P photovoltaic batteries depends on operating voltage, load value, temperature, and radiation intensity. The Maximum Power Point (MPP) is the desired working point for optimal efficiency. MPPT can increase solar power output by adjusting parameters, ensuring the working voltage ( $V$ ) remains equal to optimal VTM. MPP is crucial in solar-powered electric vehicles, as it ensures high electricity availability without increasing solar panel size and reducing vehicle weight and performance [36]. The classification of optimization techniques is shown in Fig. 6.

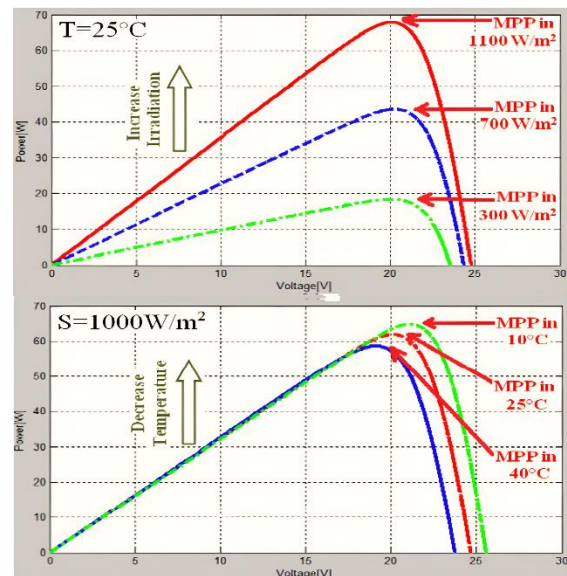

**Fig. 6** Classification of Optimization Techniques [6].

MPPT comprises hardware and software components, including a DC converter, sensors, and control unit. Researchers have developed various TMM tracking algorithms, with the incremental conductivity (IC) algorithm being the most effective in various weather conditions. The IC algorithm provides the highest efficiency in real environments. A microgrid based on PV uses a modified P&O algorithm to eliminate fluctuations and initial panel parameters, while the adaptive P&O algorithm improves dynamic response and stability [37].

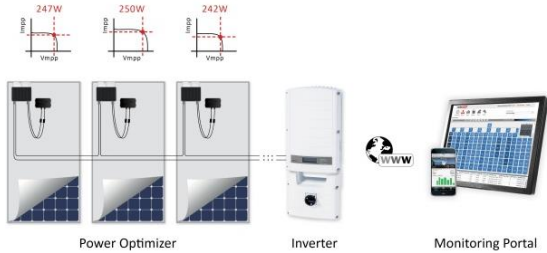

**Fig. 7** Use of Power Optimizers for Solar Cells [7].

Replacing inverters on the power curve is determined using the iterative current I balance (IB) method, which yields a positive or negative slope for output power. This method aids in maximizing the power of each module while decreasing energy efficiency in PV modules by up to 50–60%. Since 2006, inverters have combined the benefits of single and micro-inverters, increasing energy production, boosting security, and providing continuous information from each panel. This method also enables replacing outdated or defective modules with new, more potent ones, increasing a PV system's efficiency by 25% annually. Optimizers calculate the location of solar PV modules on the power curve by changing current by a slight I deviation, resulting in a positive or negative slope of output power, allowing for the iterative wind I balance to approach the MPPT. These optimizers improve energy efficiency by reducing power losses and ensuring safety in photovoltaic systems [8]. In the renewable energy scenario of tomorrow, the volatile demand for energy in many countries is currently met by combining points produced from sun, wind, and water (renewable energy sources, RES) plus that from fossil energy sources (FES, Eq. (2)), will be met by renewable energy only (Eq. (3)) [38,39].

$$\begin{matrix} \text{Demand} & = & \text{Production from RES} & + & & \\ \text{(Volatile)} & & \text{(Volatile)} & & \text{(Plannable)} & \end{matrix} \quad (2)$$

$$\begin{matrix} \text{Demand} & = & \text{Production from RES} & \\ \text{(Volatile)} & & \text{(Volatile)} & \end{matrix} \quad (3)$$

Recent progress in weather forecasting, mainly through neural network algorithms, has

enabled accurate predictions of renewable energy production from the sun and wind. This technology increased efficiency in PV modules [40-42] and renewable energy capacity with maximum output and fast connection to the electrical network. Whereas machine learning algorithms predict the dynamic volatility of electric C-type stems where distributed generation exceeds 50%. The increasing number of renewable sources can generate up to 25–30% of electricity, developing microgrids and greater decentralization of energy sources. The Internet of Things role will also increase [43]. The North Star ACE project aimed to increase efficiency through built-in sensors and controllers in each battery and optimize the overall operation of solar panels and electric energy storage devices, achieving maximum generation and optimal electricity accumulation [44]. North Star ACE sensors and controllers allow :

- Measure voltage and temperature.
- Eliminate the need for external monitoring devices.
- Save the charge of storage devices during data transmission.
- Store critical parameters that affect battery performance throughout battery life.
- Collect information for future optimization.
- Keep a log automatically without any active consumer intervention.
- Create an intelligent power grid when many homes are connected. Fig. 8 shows how North Star ACE works.

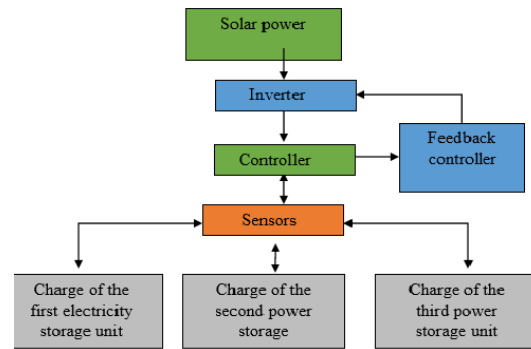

**Fig. 8** Principle of North Star ACE Work.

The IoT is an innovative electronic optimizer technology for lithium-ion cells, measuring the charge of solar panels and rechargeable modules relative to each other. The bi-directional cell control and balancing system in a 48 kW ×h battery can detect and correct these differences continuously, ensuring a balanced charge state with minimal energy loss [45]. The examples can be presented as a scheme of the Internet of Things and solar power plants for small networks (Fig. 9).

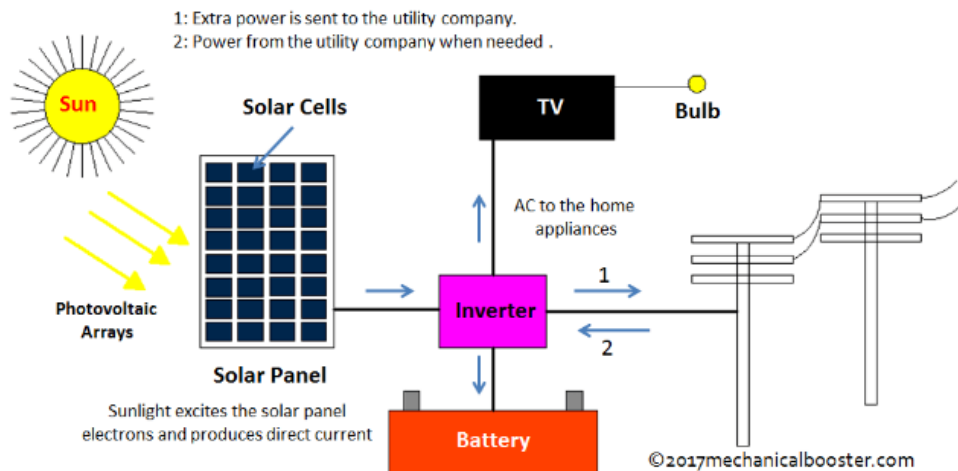

**Fig. 9** Working on Solar Plant.

**6.THE PERFORMANCE OF THE PV MONITORING APPLICATION**

Using power optimizers for solar cells, a smartphone application was developed to simplify data user access, displaying up to 6 sensors' data. Created using MIT App Inventor, the program provides a better visual representation of the data, as shown in Fig. 10.

**Table 1** Data Calibration of Each Sensor Utilized in Data Acquisition.

Sensor Type	Number of data	Percentage of difference from the standard measuring instrument ( $\mu \pm 1\sigma$ %)
Voltage	30 × 10a	3.05 ± 3.25
Current	30 × 6b	1.85 ± 1.57
Temperature	30	0.22 ± 1.38
Light intensity	30	0.92 ± 3.03

The voltage and current sensors were calibrated using a power supply voltage range of 1-10 V.

The sensors' mean and standard deviation values were 3.05-3.25, 1.85-1.57, 0.22-1.38, and 0.92-3.03%, respectively. The overall mean accuracy was 98.49%, indicating good working order and accurate data acquisition. The performance of the PV system was examined from 06:00-18.00, and the power was calculated using the formula  $P = V I$  in Watt. Access to the PV panel monitoring system is possible through the website and the PV Monitor application described in this study. The data shown is produced by both techniques in the same way. The only difference was that the data were shown simultaneously on the Internet, as seen in Fig. 8. The PV Monitor program, in contrast, enables users to choose which data should be presented while concealing the others. The display for the PV Monitor is shown in Figs. 8 and 9.

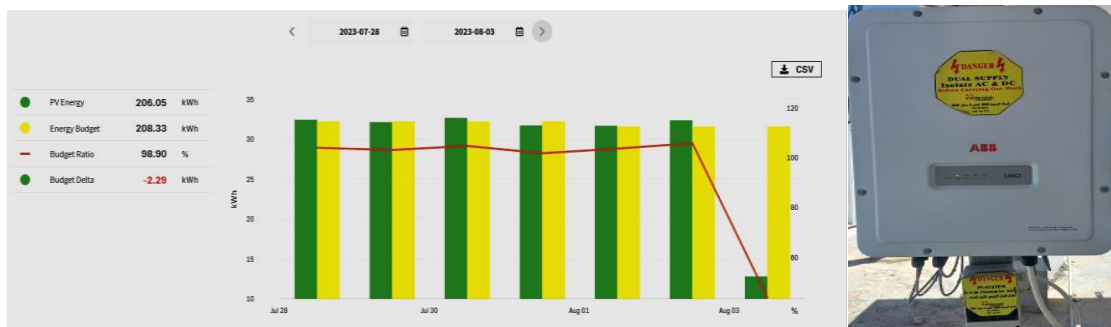

**Fig. 10** Performance of the PV monitoring.



**Fig. 11** The PV Monitor AC Output Power Display.

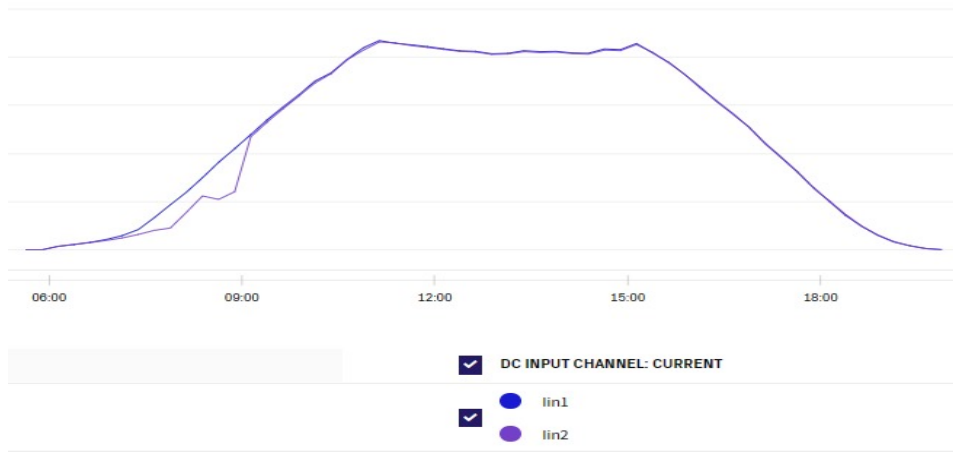

**Fig. 12** The PV Monitor DC Input Channel Current.

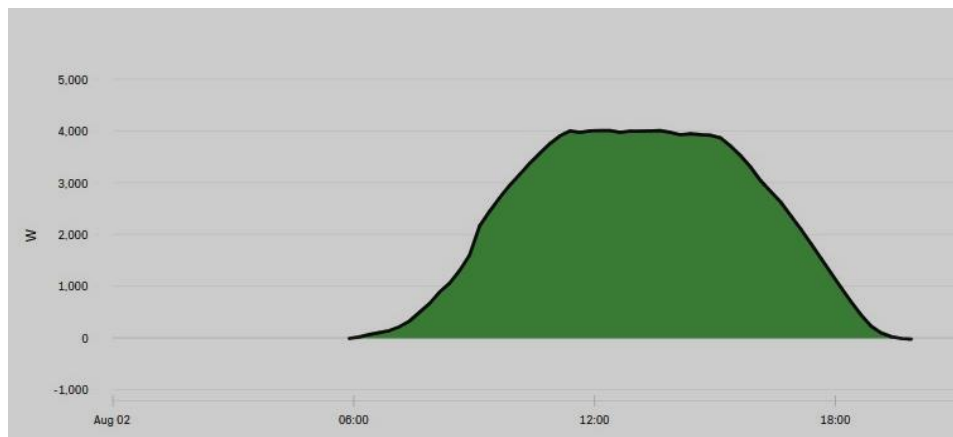

**Fig. 13** The PV Monitor Generated Energy of 23.40 kWh.

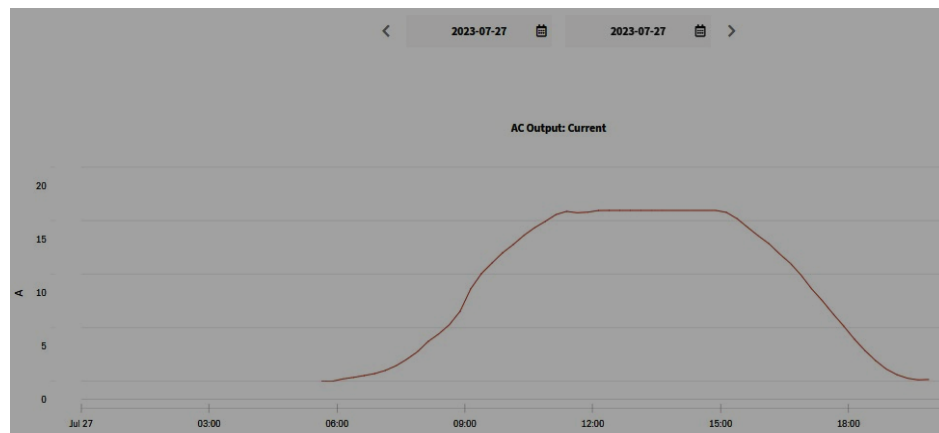

**Fig. 14** The PV Monitor AC output Current Display.



**Fig. 15** PV Performance System Result of Power Versus Monitoring System.



## 7. CONCLUSIONS

IoT systems and databases facilitate producing hydroelectricity, encourage using solar power, and manage water resources, as evidenced by the Framework for Planning a Climate-Resilient Economy, Geothermal Prospector, US Energy Information Administration energy mapping system, and Bioenergy Knowledge Discovery Framework, and the solar road map. For various energy applications, digital control technology and energy storage in Li-ion batteries and solar hydrogen enable producing pure, dependable, and cost-effective solar electricity. In large cities, where 30% of annual demand is met through self-generation of electricity via building-integrated PV, solutions could be scaled up. Nonetheless, the liberalized electricity market requires structural adjustments, including renewable energy sources and governance models. To direct organizations toward energy self-sufficiency, energy managers must articulate and implement a tangible energy transition strategy. Solar PV system monitoring requires data acquisition, a data gateway, and the display of a smartphone application. The data acquisition process was executed with an accuracy rate of 98.49%. Graphical representations were transmitted to the smartphone application via the data gateway in an average of 52.34 seconds using a PV system; one can significantly outweigh the disadvantages of relying on a costly and transient UPS battery. Further research will concentrate on implementing active cooling devices and MPPT algorithms to enhance the output and efficiency of photovoltaic (PV) systems.

## NOMENCLATURE

FES	Fossil Energy Sources
IoT	The Internet of Things
MMPT	Maximum Peak Power Tracking
MOPSO	Multi-Objective Particle Swarm Optimization
MPPT	Maximum Power Point Tracking
PPAs	Direct Power Purchase Agreements
PV	Photovoltaic
RES	Renewable Energy Sources
RSM	Response Surface Methodology

## REFERENCES

- [1] Handam A, Al Smadi T. **Multivariate Analysis of Efficiency of Energy Complexes Based on Renewable Energy Sources in the System Power Supply of Autonomous Consumer.** *International Journal of Advanced and Applied Sciences* 2022; **9**(5):109-118.
- [2] Gaeid KS, Homod RZ, Mashhadany YA, Smadi TA, Ahmed MS, Abbas AE. **Describing Function Approach with PID Controller to Reduce Nonlinear Action.** *International Journal of Electrical and Electronics Research* 2022; **10**(4):976-983.
- [3] Zhou Y. **Sustainable Energy Sharing Districts with Electrochemical Battery Degradation in Design, Planning, Operation and Multi-Objective Optimization.** *Renewable Energy* 2023; **202**: 1324–1341.
- [4] Al-Husban Y, Al-Ghriybah M, Handam A, Al Smadi T. **Residential Solar Energy Storage System: State of the Art, Recent Applications, Trends, and Development.** *Journal of Southwest Jiaotong University* 2022; **57**(5): 1-20.
- [5] Al-Agha OI, Alsmadi KA. **Overview of Model Free Adaptive (MFA) Control Technology.** *International Journal of Artificial Intelligence* 2018; **7**(4):165-169.
- [6] Gaeid KS, Al Smadi T, Abubakar U. **Double Control Strategy of PMSM Rotor Speed-Based Traction Drive Using Resolver.** *Results in Control and Optimization* 2023; **13**:100301, (1-12)
- [7] Pagliaro M, Meneguzzo F. **Digital Management of Solar Energy En Route to Energy Self-Sufficiency.** *Global Challenges* 2019; **3**(8):1800105, (1-8).
- [8] Al Smadi TA. **Computer Application Using Low Cost Smart Sensor.** *International Journal of Computer Aided Engineering and Technology* 2012; **4**(6) :567-579.
- [9] Shaker AM. **Optimum Design of Parabolic Solar Collector with Exergy Analysis.** *Tikrit Journal of Engineering Sciences* 2017; **24**(4):94-75.
- [10] Abbasi A, Sultan K, Aziz MA, Khan AU, Khalid HA, Guerrero JM, Zafar BA. **A Novel Dynamic Appliance Clustering Scheme in a Community Home Energy Management System for Improved Stability and Resiliency of Microgrids.** *IEEE Access* 2021; **13**(9):142276-142288.
- [11] Zapar WM, Gaeid K, Mokhlis HB, Al Smadi TA. **Review of the Most Recent Articles in Fault Tolerant Control of Power Plants 2018–2022.** *Tikrit Journal of Engineering Sciences* 2023; **30**(2):103-113.
- [12] Hasanien HM. **Performance Improvement of Photovoltaic Power Systems Using an Optimal Control Strategy Based on Whale Optimization Algorithm.** *Electric Power Systems Research* 2018; **157**:168-176.
- [13] Abu-Jassar AT, Al-Sharo YM, Lyashenko V, Sotnik S. **Some Features of Classifiers Implementation for Object Recognition in Specialized**

- Computer systems.** *TEM Journal* 2021; **10**(4): 1645-1654.
- [14] Al Smadi T, Handam A, Gaeid KS, Al-Smadi A, Al-Husban Y. **Artificial Intelligent Control of Energy Management PV System.** *Results in Control and Optimization* 2023; **14**:100343, (1-13).
- [15] Al-Husban Y, Al-Ghriybah M, Gaeid KS, Takiyaldin AS, Handam A, Alkhazaleh AH. **Optimization of the Residential Solar Energy Consumption Using the Taguchi Technique and Box-Behnken Design: A Case Study for Jordan.** *International Journal on Energy Conversion (IRECON)* 2023; **11**(1) : 25-33.
- [16] Alhasnawi B, Jasim B, Siano P, Guerrero J. **A Novel Real-Time Electricity Scheduling for Home Energy Management System Using the Internet of Energy.** *Energies* 2021; **14**(11): 3191, (1-29).
- [17] Shatnan WA, Almawlawe MDH, Jabur MAAA. **Optimal Fuzzy-FOPID, Fuzzy-PID Control Schemes for Trajectory Tracking of 3DOF Robot Manipulator.** *Tikrit Journal of Engineering Sciences* 2023; **30**(4):46-53.
- [18] Franco P, Martínez JM, Kim YC, Ahmed MA. **A Framework for IoT Based Appliance Recognition in Smart Homes.** *IEEE Access* 2021; **9**: 133940-133960.
- [19] Gaeid KS, Al Smadi T, Abubakar U. **Double Control Strategy of PMSM Rotor Speed-Based Traction Drive Using Resolver.** *Results in Control and Optimization* 2023; **13**:100301, (1-8).
- [20] Trrad I, Smadi TA, Al\_Wahshat H. **Application of Fuzzy Logic to Cognitive Wireless Communications.** *International Journal of Recent Technology and Engineering (IJRTE)* 2019; **8**(3):2228-2234.
- [21] Al-Maitah M, Al Smadi TA, Al-Zoubi HQ. **Scalable User Interface.** *Research Journal of Applied Sciences, Engineering and Technology* 2014; **7**(16):3273-3279.
- [22] Al-Smadi TA, Al-Wahshat H. **System Identification of the Logical Object and Logical Acupuncture.** *International Journal of Physical Sciences* 2011; **6**(15):3771-3777.
- [23] Twfek KG, Mansour EA. **Theoretical and Experimental Analysis for Performance of Wind Turbine.** *Tikrit Journal of Engineering Sciences* 2020; **27**(4):114-120.
- [24] Wali SA, Muhammed AA. **Power Sharing and Frequency Control in Inverter-based Microgrids.** *Tikrit Journal of Engineering Sciences* 2022; **29**(3):70-81.
- [25] Hilme I, Abdulkafi AA. **Energy-Efficient Massive MIMO Network.** *Tikrit Journal of Engineering Sciences* 2023; **30**(3): 1-8.
- [26] BSI Standards. **Internet of Things (IoT) Interoperability for IoT Systems.** (n.d.). 2022; BS ISO/IEC 21823-4.
- [27] Miller WJ. **Internet of Things (IoT) for smart energy systems.** In: Gabbar HA. *Smart Energy Grid Engineering.* Oshawa, Canada: Academic Press; 2017, p. 237-244.
- [28] Bedi G, Venayagamoorthy GK, Singh R, Brooks RR, Wang KC. **Review of Internet of Things (IoT) in Electric Power and Energy Systems.** *IEEE Internet of Things Journal* 2018; **5**(2): 847-870.
- [29] Hossein Motlagh N, Mohammadrezaei M, Hunt J, Zakeri B. **Internet of Things (IoT) and the Energy Sector.** *Energies* 2020; **13**(2):494, (1-27).
- [30] Al-Sharo YM, Abu-Jassar AT, Sotnik S, Lyashenko V. **Generalized Procedure for Determining the Collision-Free Trajectory for a Robotic Arm.** *Tikrit Journal of Engineering Sciences* 2023; **30**(2):142-151.
- [31] Alowaidi M. **Fuzzy Efficient Energy Algorithm in Smart Home Environment Using Internet of Things for Renewable Energy Resources.** *Energy Reports* 2022; **8**: 2462-2471.
- [32] Murdan AP. **Internet of Things for Enhancing Stability and Reliability in Power Systems.** *Journal of Electrical Engineering, Electronics, Control and Computer Science* 2023; **9**(3):1-8.
- [33] Jamroen C, Yonsiri N, Odthong T, Wisitthiwong N, Janreung S. **A Standalone Photovoltaic/Battery Energy-Powered Water Quality Monitoring System Based on Narrowband Internet of Things for Aquaculture.** *Design and Implementation Smart Agricultural Technology* 2023; **3**:100072, (1-14).
- [34] Al-Smadi TA, Ibrahim YK. **Design of Speed Independent Ripple Carry Adder.** *Journal of Applied Sciences* 2007; **7**(6):848-854.
- [35] Ahmed ZE, Hasan MK, Saeed RA, Hassan R, Islam S, Mokhtar RA, Khan S, Akhtaruzzaman M. **Optimizing Energy Consumption for Cloud Internet of Things.** *Frontiers in Physics* 2020; **8**:358, (1-10).
- [36] Mohd Aman AH, Hassan R, Hashim AH, Ramli HA. **Investigation of Internet of**

- Things Handover Process for Information Centric Networking and Proxy Mobile Internet Protocol.** *Mehran University Research Journal of Engineering & Technology* 2019; **38**(4):867-874.
- [37] Takiaddin AS, Al Smadi K, AL-Smadi OO. **High-Speed for Data Transmission in GSM Networks Based on Cognitive Radio.** *American Journal of Engineering and Applied Sciences* 2017; **10**(1):69-77.
- [38] Pan J, Jain R, Paul S, Vu T, Saifullah A, Sha M. **An Internet of Things Framework for Smart Energy in Buildings: Designs, Prototype, and Experiments.** *IEEE Internet of Things Journal* 2015; **2**(6):527-537.
- [39] Raval M, Bhardwaj S, Aravelli A, Dofe J, Gohel H. **Smart Energy Optimization for Massive IoT Using Artificial Intelligence.** *Internet Things* 2021; **13**:100354.
- [40] Ayyad S, Baker MB, Handam A, Al-Smadi T. **Reducing the Highway Networks Energy Bills Using Renewable Energy System.** *Civil Engineering Journal* 2023; **9**(11):2914-2926.
- [41] Villas LA, Boukerche A, De Oliveira HA, De Araujo RB, Loureiro AA. **A Spatial Correlation Aware Algorithm to Perform Efficient Data Collection in Wireless Sensor Networks.** *Ad Hoc Networks* 2014; **12**:69-85.
- [42] Dash L, Pattanayak BK, Laha SR, Pattnaik S, Mohanty B, Habboush AK, Al Smadi T. **Energy Efficient Localization Technique Using Multilateration for Reduction of Spatially and Temporally Correlated Data in RFID System.** *Tikrit Journal of Engineering Sciences* 2024; **31**(1): 101–112.
- [43] Mahmood MS, Al Dabagh NB. **Improving IoT Security using Lightweight Based Deep Learning Protection Model.** *Tikrit Journal of Engineering Sciences* 2023;**30**(1):119-129.
- [44] Shatnan WA, Almawlawe MD, Jabur MA. **Optimal Fuzzy-FOPID, Fuzzy-PID Control Schemes for Trajectory Tracking of 3DOF Robot Manipulator.** *Tikrit Journal of Engineering Sciences* 2023;**30**(4):46-53.
- [45] Mohanty MN, Satrusallya S, Al Smadi T. **Antenna Selection Criteria and Parameters for IoT Application.** In: Malik PK, Naim A, Singh R. Printed Antennas. Boca Raton, USA: CRC Press; 2022, p. 283–295.
- [46] Abdullah SF, Nawaf SF. **Optimizing Data Security with Hybrid Scheme Based on LSB and DWT.** *Tikrit Journal of Engineering Sciences* 2023; **30**(3):190-199.