

CONCATENATION OF TRELLIS- CODED MODULATION AND SPACE-TIME CODE FOR WIRELESS COMMUNICATIONS ⁺

سلسلة الترميز الشبكي المضمن والترميز الحيزي الزمني للاتصالات اللاسلكية

Mahmood Farhan Mosleh *

Imad Hazim Mohomad**

Salam Ibrahim Kadim***

Abstract:

In wireless communication system it can achieve increases in the reliability of data reception without bandwidth expansion by using antenna diversity. Space-Time Block Codes (STBC) can achieve the full diversity gain with very simple decoding but cannot get perfect performance for coding gain. Trellis-Coded Modulation (TCM) is a kind of channel coding with improving the coding gain. Therefore, concatenation of STBC and TCM is a combined channel coding to achieve both diversity gain and coding gain advantages. In this paper the performance of TCM is evaluated alone and so for STBC with two transmit and one received antennas, as well as concatenated STBC with TCM over frequency flat fading channel. The simulation results illustrates that concatenation system is robust for various level of Signal to Noise Ratio (SNR) in multipath fading channel. Simulink implementation has been done for such system.

المستخلص :

في أنظمة الاتصالات اللاسلكية، يمكن الحصول على زيادة في وثوقية البيانات المستلمة بدون زيادة عرض النطاق الترددي المستخدم وذلك باستخدام التنوع بالهوائيات. الترميز بحيزي الزمن والمقطع (STBC)، هذا النوع من الترميز يمكن الحصول من خلاله على تنوع كامل وبمحلل شفرة بسيط ولكن لا يمكن على الحصول ربح المرمز بصورة مؤكدة. الترميز الشبكي المضمن (TCM) هو احد الانواع المستخدمة في تحسين ربح المرمز. وعليه فان ربط المرمزين (STBC) و (TCM) سوف يمكن من الحصول على مزايا كل من ربح المرمز بالإضافة الى التنوع. في هذا البحث تم تقييم اداء كل من المرمزين اعلاه بصورة منفردة وكذلك مع بعضهما. نتائج المحاكاة بينت ان الربط المتسلسل لكلا المرمزين يعطي النظام قوة لمختلف قيم نسبة الاشارة الى الضوضاء (SNR) في ظروف القناة ذات المسارات المتعددة. وكذلك تم التطبيق المباشر للمحاكاة باستخدام برنامج (Simulink).

Introduction:

In wireless communication, fading channels cause significant degradation in transmitted signals. One useful method to reduce the adverse effects of fading channels is to employ diversity. Diversity is in general created when the same transmitted information is transmitted on several more or less independently fading channels, and it can be exploited by intelligent combining of the resulting received signals. The idea is that the repetition of information, together with an appropriate combining of the received signals in the receiver, will greatly reduce the negative effects of the radio channel fading by effectively stabilizing the channel quality, downplaying the effects of the individual fades on the different independent channels,

⁺ Received on 5/11/2009 ,Accepted on 21/10/2010 .

* Lecture / Electrical and Electronic Technical College .

** Lecture /Instructors Traning Institute .

*** Assistance Lecture / Electrical and Electronic Technical College .

and thus improving the overall quality of the received signals. Diversity can in general be achieved by creating independent channels in time, frequency, or space. Orthogonal transmit diversity, such as frequency and time diversity, have some properties that are quite attractive in wireless communication as they can provide a diversity gain without the need of multiple transmit/receive antennas. However, this gain comes at a cost of either increased bandwidth or time necessary to transmit the information [1].

Wittneben introduced the bandwidth efficient transmit diversity scheme [2] which transmits the same information from both antennas simultaneously and delay one symbol interval. After that, Tarokh proposed a new method, namely Space-Time Trellis Codes (STTC), [3], STTC is joining the channel coding with trellis encoder, modulation, and diversity. The decoding complexity at the receiver increases exponentially with the number of trellis states and transmission rate when number of transmit antennas is fixed. To decrease the decoding complexity of STTC, the first Space Time Block Code (STBC) was proposed by Alamouti over two transmit antennas and two time periods in [4]. And then Tarokh developed the Alamouti's STBC with more antennas at both transmitter and receiver in [5]. STBC can achieve advantages about the full diversity gain with no penalty in given bandwidth, and the encoding and decoding of these codes have less complexity than STTC. However; the STBC do not perform perfectly for a coding gain [6]. Thereby, the concatenation of these code with outer code such as Block-Coded Modulation (BCM) or Trellis-Coded Modulation (TCM) is an appropriate solution to combine the very easy decoding structure of the STBC with an additional coding gain and diversity gain [7]. For the systems with large number of transmit antennas and high bandwidth efficiency, the receiver may become too complex. To solve this problem, some methods were proposed such as Layered Space-Time Codes in [8] and Combined Array Processing with Space-Time Coding in [9] and [10].

This paper concentrate on STBC with two transmit and one received antennas, concatenated with TCM. To be sure that the results are actual, Simulink implementation has been done.

The paper is organized as follows. In section 2, the basic principle of STBC are reviewed. Section 3 present briefly and simple review about TCM, and so for concatenated STBC with TCM models in section 4. In section 5 we present a system model and simple explanation for each block. In section 6, bit-error performance of the basic TCM, and STBC are simulated individually as well as the concatenated of STBC over multi-path fading channels are evaluated by Matlab simulation model. Section 7 present the simulink implementation of such system, and concluding remarks are provided in section 8.

Space Time Block Codes (STBC):

Space-Time Code (STC) design performs coding across both time and space (transmit antennas) dimensions. It works with multiple transmit antennas and does not necessarily need multiple receive antennas. One the most main types of STC is STBC. STBC operate on a block of input symbols, producing a matrix output whose rows represent time and columns represent antennas as in the following matrix [5].

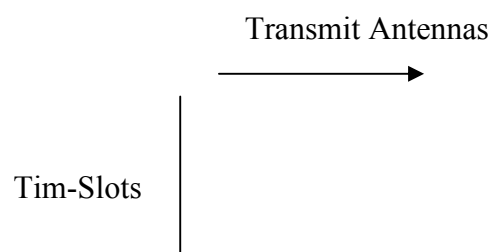

$$\begin{pmatrix} S_{11} & \cdots & S_{1n_T} \\ \vdots & \ddots & \vdots \\ S_{T1} & \cdots & S_{Tn_T} \end{pmatrix} \dots \quad (1)$$

Here, s_{ij} is the modulated symbol to be transmitted in time slot i from antenna j . There are to be T time slots and n_T transmit antennas as well as n_R receive antennas. This block is usually considered to be of 'length' T . The code rate of an STBC measures how many symbols per time slot it transmits on average over the course of one block. If a block encodes k symbols, the code-rate is:

$$r = \frac{k}{T} \quad \dots \quad (2)$$

For a simple two transmitter space-time block code, and one receiver as we focused in this paper. It can be seen from the figure (1) that there are two transmitters, T_{x1} and T_{x2} and they transmit two signals simultaneously. Assume the channel coefficients keep constant over the two consecutive symbol periods. Therefore [4]:

$$h_1(t) = h_1(t + T) = h_1 = |h_1| e^{j\theta_1} \dots \dots \dots (3)$$

$$h_2(t) = h_2(t + T) = h_2 = |h_2| e^{j\theta_2} \dots \dots \dots (4)$$

Where h_1, h_2 denotes the path gains from the two transmit antennas to receive antenna, T is the symbol period, $|h_1|, |h_2|$ are the fading magnitudes and θ_1, θ_2 are the phase values.

Independent noise samples are added at the receiver in each time slot and hence the received signals can be expressed as:

$$y_1(t) = h_1 x_1 + h_2 x_2 + n_1 \dots \dots \dots (5)$$

$$y_2(t) = -h_1 x_2^* + h_2 x_1^* + n_2 \dots \dots \dots (6)$$

Where y_1 is the first received signal, y_2 is the second, and $*$ denotes complex conjugate. Notice that the received signal y_1 consists of the transmitted signal x_1 and x_2 while y_2 of their conjugates. In order to determine the transmitted symbols, we have to extract the signals x_1 and x_2 from the received signals y_1 and y_2 . Therefore, both signals y_1 and y_2 are passed to the combiner, as shown in Figure (1). In the combiner, aided by the channel estimator, it provides perfect estimation of the diversity channels. In order to extract x_1 [11]:

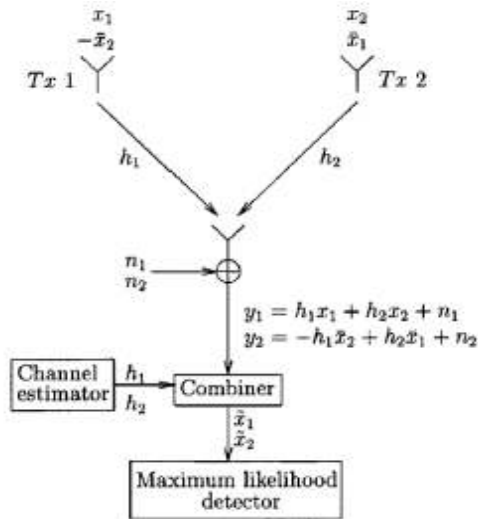

Figure (1): Representation of STBC with two-transmitter and one-receiver [12].

$$\tilde{x}_1 = h_1^* y_1 + h_2 y_2^* \dots\dots\dots(7)$$

$$\tilde{x}_1 = h_1^* h_1 x_1 + h_1 h_2 x_2 + h_1^* n_1 - h_2 h_1^* x_2 + h_2 h_2^* x_1^* + h_2 n_2^* \dots\dots\dots(8)$$

$$\tilde{x}_1 = (|h_1|^2 + |h_2|^2) x_1 + h_1^* n_1 + h_2 n_2^* \dots\dots\dots(9)$$

Similarly for the signal x_2 :

$$\tilde{x}_2 = (|h_1|^2 + |h_2|^2) x_2 + h_2^* n_1 - h_1 n_2^* \dots\dots\dots (10)$$

Clearly, from (9) and (10), it can be seen that x_1 and x_2 can be separated by simple multiplications and additions. Due to the orthogonality of the STBC the unwanted signal x_2 , is cancelled out in Equation (9) and vice versa, signal x_1 is removed from Equation (10). Both signals \tilde{x}_1 and \tilde{x}_2 are then passed to the maximum likelihood detector. The maximum likelihood decision rule at the receiver is Choose x_i , if only if :

$$(|h_1|^2 + |h_2|^2 - 1) |x_i|^2 + d^2(\tilde{x}, x_i) \leq (|h_1|^2 + |h_2|^2 - 1) |x_k|^2 + d^2(\tilde{x}, x_k) \quad \forall i \neq k$$

For equal energy constellation, the above decision rule can be simplified to: Choose x_i , if only if:

$$d^2(\tilde{x}, x_i) \leq d^2(\tilde{x}, x_k) \quad \forall i \neq k \dots\dots\dots(11)$$

Trellis – Coded Modulation TCM:

TCM is a modulation scheme which allows highly efficient transmission of information over band-limited channels such as telephone lines. Trellis modulation was invented by Gottfried Ungerboeck [13]. The functions of a TCM consist of a Trellis Code and a Constellation Mapper as shown in Figure (2) TCM combines the functions of the convolutional coder of rate: $R=k/(k+1)$ and a M-ary signal mapper that maps $M=2^k$ input points into a larger constellation of $M=2^{k+1}$ constellation points.

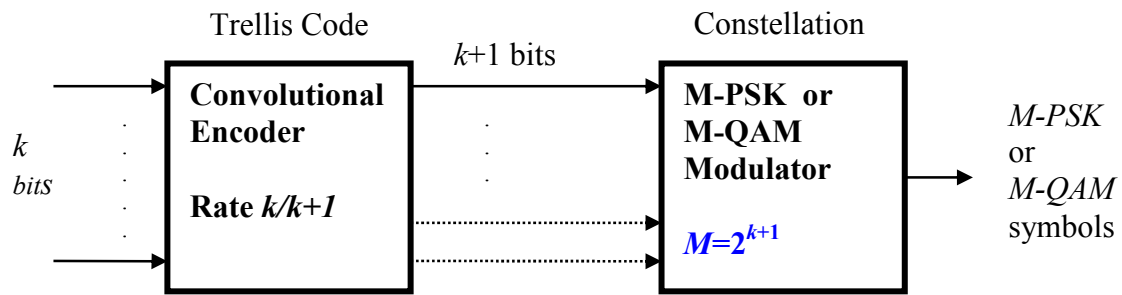

Figure (2): General Trellis Coded Modulation [12].

The Concatenated STBC with TCM:

To combine the benefit of STBC and the TCM, Concatenation is also frequently employed in space-time coded systems. In this case, the outer code is frequently a TCM system whose symbols are transmitted via an inner space-time coded system [14].

System model:

The block diagram of the overall system model is presented in Figure 3. The random data source generator generates digital information bits. This information bits is passed to the Trellis-Coded Modulation (TCM), and then the sequences get into the encoder of STBC.

The 2x1 Fading Channel is a subsystem-based implementation. It uses the [Multipath Rayleigh Fading Channel](#) block to simulate the flat Rayleigh fading subchannel from one transmit antenna to the receive antenna.

The `Maximum Doppler shift` parameter of the Multipath Rayleigh Fading Channel block is set to 30Hz. The reason for using this value is to make the Multiple Input Multiple Output (MIMO) channel behave like a quasi-static fading channel, i.e., it keeps constant during one frame transmission and varies along multiple frames.

At the receiver, the received signals by receive antennas are sent to STBC Decoder to detect transmitted symbol sequences, the decoding of STBC can achieve by using a Maximum-Likelihood Decoding Algorithm which is based only on Linear Processing.

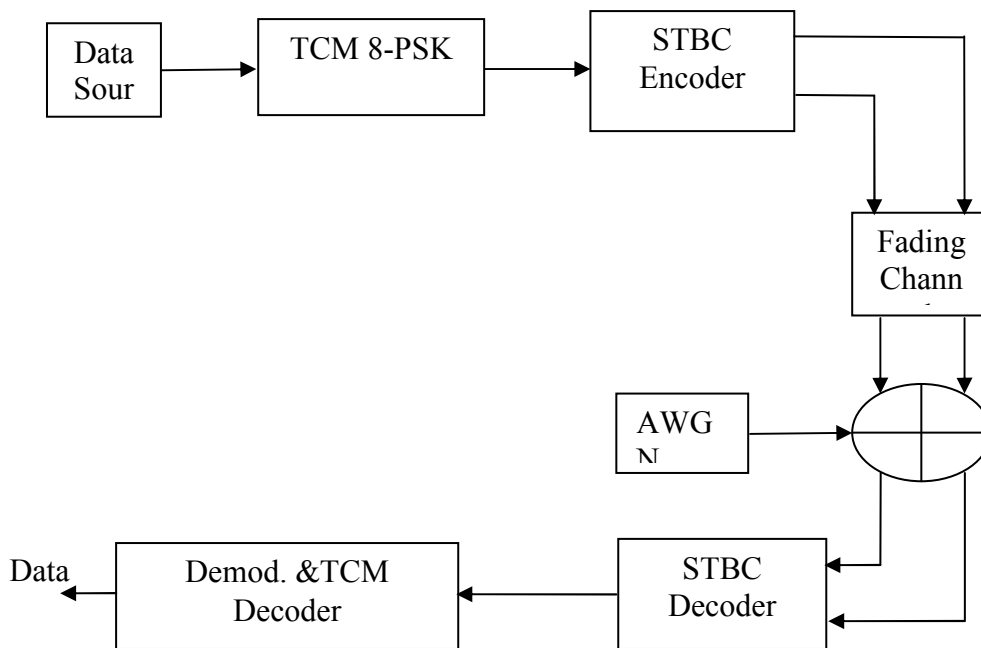

Figure(3): The Concatenated Space-Time Block Codes and Trellis-Coded Modulation

Simulation and Results:

The simulations are carried out by Matlab 7.8.0, to illustrates the advantages of a STBC and TCM concatenation scheme, the spatial diversity gain offered by STBC, and the coding gain offered by TCM. For comparison, two reference models containing only TCM or STBC are also provided. The diversity and coding gains of the concatenation scheme over the reference models can be clearly observed from the simulation and results.

1 TCM only

This section shows simulation and results when using a TCM only. This model is shown in figure 4.

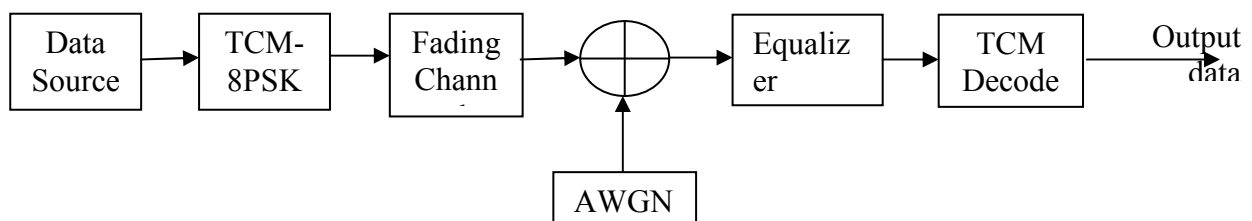

Figure(4): TCM over flat fading channel

The [8-PSK TCM Encoder](#) block modulates the message data from the data source to a 8PSK constellation that has unit average energy. In this model, we use the Ungerboeck TCM scheme for 8-PSK constellation with 8 trellis states. The Equalizer subsystem compensates the fading channel effect at the receiver side and its output is fed into the TCM Decoder block for decoding. Note that the channel is flat Rayleigh fading in this model. The Frame Error Rate (FER) versus Signal to Noise Ratio (SNR) performance result is shown in figure 6.

This system need SNR more than 40dB to achieve 10^{-4} FER which is difficult for modern communications.

2 STBC only

As shown in figure 5 this model replaces the TCM in the above concatenation scheme (Figure 3) by a QPSK modulation so that both the models have the same symbol (frame) rate, and identical fading channel parameters. The reason is to clear up the effect of TCM existing in the system model instead of QPSK which will evaluated in the next subsection.

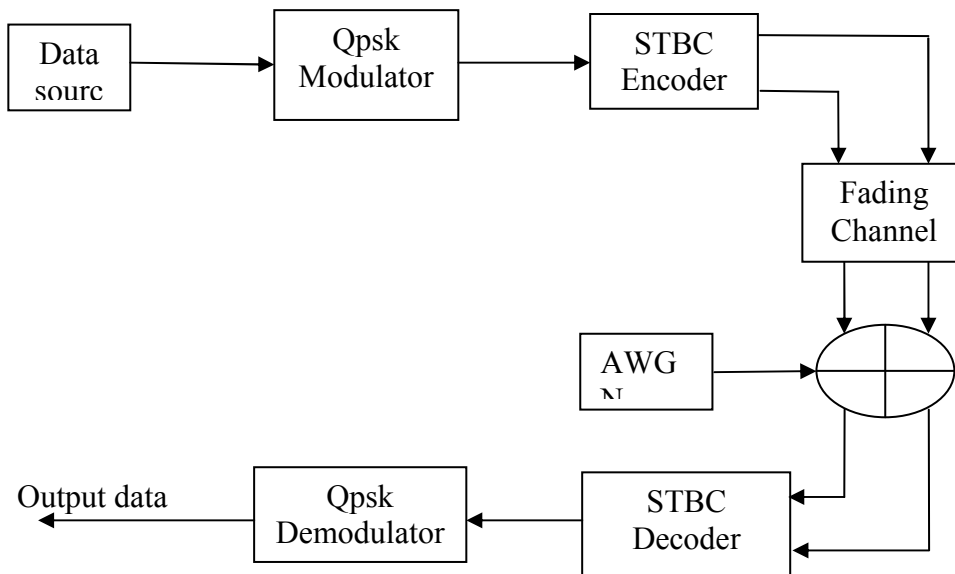

Figure(5): STBC over (2 x 1) flat fading channel

It uses the same 2x1 Fading Channel subsystem as in the TCM-STBC concatenation model. The [QPSK Modulator Baseband](#) block maps the information bits to a QPSK constellation and the [QPSK Demodulator Baseband](#) block demodulates the signals from the STBC combiner. Figure 6 illustrates the amount of STBC capability to mitigate fading channel stem from mobility environment.

It is clear from figure 6 that STBC gains more than 10dB improvement at BER level of 10^{-4} STBC. On the other hand STBC can achieve advantages about the full diversity gain with no penalty in given bandwidth, and the encoding and decoding of these codes have less complexity.

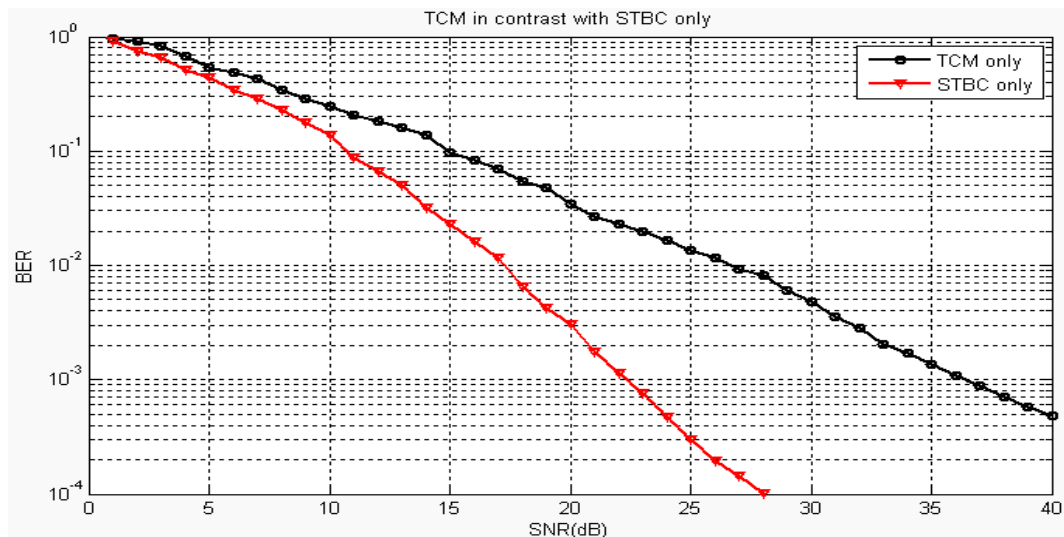

Figure 6: Simple transceiver with STBC and QPSK

3 Concatenated STBC with TCM

As mentioned, to clear out the benefit of concatenated STBC with TCM shown in figure 3, all environments used in previous subsections for TCM and STBC individually are the same as in this section. The performance shown in figure 8 illustrates that such system outperform reference system (6-2 subsection) by about 2dB for all level of SNR.

System model simulator:

In order to have a general view of our system model simulator described through this paper, a complete block diagram of the Simulink model is given in Figure 8. A brief description of the different blocks is exposed with the purpose of offering a better understanding of the figure.

The [Bernoulli Binary Generator](#) block produces the information source for this simulation. The block generates a frame of 100 random bits. The Samples per frame parameter determines the length of the output frame (100 in this case).

The [8-PSK TCM Encoder](#) block modulates the message data from the Bernoulli Binary Generator to a PSK constellation that has unit average energy. The size of the PSK constellation we use the Ungerboeck TCM scheme for 8-PSK constellation with 8 trellis states. The trellis structure parameter is set to $([2\ 3], [1\ 2\ 0; 4\ 1\ 2])$. This block has an output frame length of 50 as every two input bits produce one symbol.

The [STBC Encoder](#) block encodes the information symbols from the TCM Encoder by using the Alamouti code [4] for 2 transmit antennas. The output of this block is a 50x2 matrix whose entries on each column correspond to the data transmitted over one antenna.

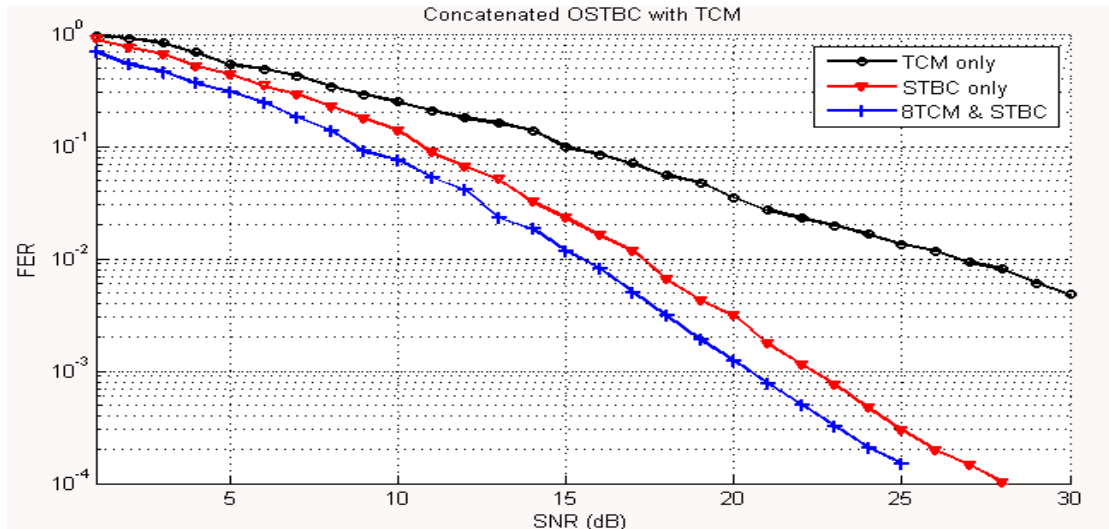

Figure 7: The performance of concatenated STBC with 8-TCM

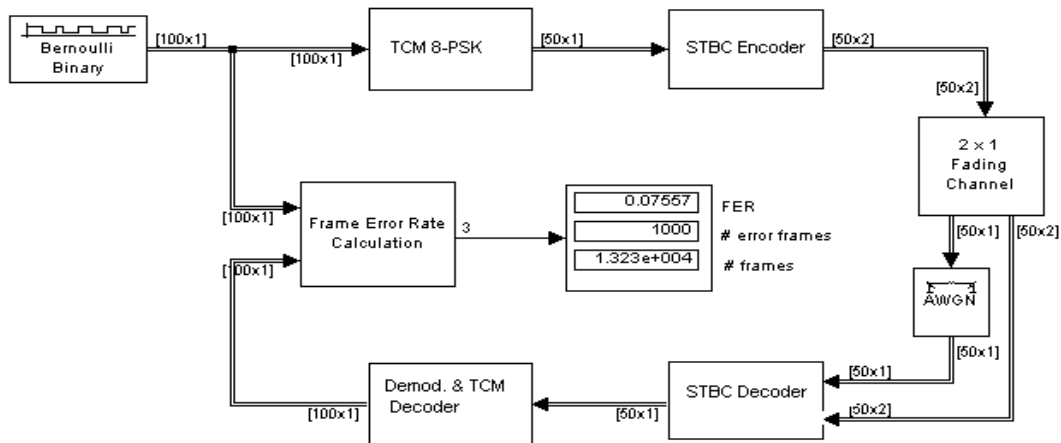

Figure 8: Simulink block diagram of the system model

Then, the signal is sent over the channel. The 2x1 Fading Channel is a subsystem-based implementation. It uses the [Multipath Rayleigh Fading Channel](#) block to simulate the flat Rayleigh fading subchannel from one transmit antenna to the receive antenna. The [AWGN Channel](#) block adds white Gaussian noises at the receiver side. The Mode parameter is set to SNR mode and the input signal power, is set to 1 ohm (watts) and the gain of each MIMO subchannel is normalized.

The receiver performs the reverse operations to get the transmitted data. The [STBC decoder](#) block combines the received signals from the receive antenna with the Channel State Information (CSI) to output the estimates of the transmitted symbols, which are then fed into the 8-PSK TCM Decoder. In this case, the CSI is assumed perfectly known at the receiver side.

The [Demodulator and TCM Decoder](#) block uses the Viterbi algorithm for TCM to decode the signals from the STBC decoder.

The Frame Error Rate (FER) Calculation subsystem compares the decoded bits with the original source bits per frame to detect errors and dynamically updates the FER along the simulation. The output of this subsystem is a three-element vector containing the FER, the number of error frames observed and the number of frames processed.

Conclusions:

Based on the simulation results above, it is shown that, the significant gains can be achieved by using STBC system. It outperform TCM only by 15dB at 10^{-3} BER. While the combination of STBC and TCM improve the system by 2dB over every level of SNR (see Figure 7), which evidence that this scheme is suitable for recent communication systems that used in various environments because of mobility employing. The Simulink program confirm that our scheme is able to be implemented in hardware form.

References:

- 1- Mikael Gidlund, "Performance of Combined Constellation Rearrangement and Space-Time Block Coding Scheme for Multilevel Modulation", *Proc. Int. Symp. On personal, Indoor and Mobile Radio Communications, Athens, Greece, p. 1-6. 2007.*
- 2- Wittneben , A., "Base station modulation diversity for digital SIMUL-CAST" , *in Proc. 4 Ist VTS Conf., St. Louis Missouri, pp, 848-853, May 1991.*
- 3- Tarokh, V., Seshadri, N. and Calderbank, A. R., "Space-time codes for high data rate wireless communication: Performance Criterion and Code Construction," *IEEE Trans. Inform. Theory*, vol. 44, pp.744–765, March 1998.
- 4- Alamouti, S.M., "A simple transmit diversity technique for wireless communications", *IEEE Journal on Selected Areas in Communications*, vol.16 pp. 1451-1458, October 1998.
- 5- Tarokh, V., Jafarkhani and H., Calderbank , A. R., "Space-Time Block codes from orthogonal designs" *IEEE Journal on Selected Areas in Communications*,, vol.45 no.5 ,pp.1456-1467, July 1999.
- 6- Sandhu S., R. Heath, A. Paulraj, "Space- Time block codes versus space-time trellis codes", *IEEE International Conference, vol.4, 11-14*, pp. 1132-1136, June 2001.
- 7- Hanzo, L., Liew T.H and Yeap. B. L, " Turbo Coding, Turbo equalization and Space-Time Coding for Transmission over Fading Channel", *IEEE Press*, pp. 416-422, pp. 464-468, 2002.
- 8- Da-shan Shiu and Joseph, M. Kahn,"Layered Space-Time Codes for Wireless Communications Using Multiple Transmit Antennas", *ICC 99, Vancouver, Canada*, pp. 155-159, June 1999.
- 9- Jöngren, G., Skoglund, M., and Björn Ottersten, "Combining Beam forming and Orthogonal Space-Time Block Coding ",*IEEE Trans. on Infor. Theory*, Vol. 48, No.3, pp. 611-627, March, 2002.
- 10 Tarokh, V., Naguib, A., Seshadri , N. and Calderbank, " Combined array processing and space – time coding ", *IEEE Trans. On Inform. Theory*, vol.45, no.4, pp.1121-1128, May 1999.
- 11 A. J. Jameel and Y. Xiaohu, "Concatenation of Turbo Codes and Space-Time Block Codes for Fading Channels", *IEEE Trans. On Inform. Theory*, vol.45, no.4, pp.1121-1128, May 1999.
- 12 Thuraya Mahmood "*Simulation of Hybrid System with (SFBC-STBC OFDM) in Wireless Communication System*", PhD. Dissertation. Electromechanical Department. University of Technology, Iraq. 2008.
- 13 Ungerboeck, G., "Channel Coding with Multilevel/phase Signal," *IEEE Transaction on Information Theory*, vol. IT-28 1982.
- 14 Todd K. Moon, " *Error Correction Coding*", John Wiley & Sons, Inc., Hoboken, New Jersey, 2005.