

MULTIUSER ON DS-CDMA IN PRESENCE OF THREE-PATH FADING CHANNEL ⁺

المستخدمين المتعددين في الطيف المنتشر نوع التتابع المباشر – تقسيم الترميز المتعدد بوجود ثلاث مسالك لقناة تضاعل الإشارة

Sadiq Kamel Gharkan *

Abstract :

Direct Sequence Code Division Multiple Access (DS-CDMA) communication system have attracted considerable attention for third-generation (3G) mobile system .They have the ability to suppress a wide variety of interfering signals including Narrow-Band (NB) ,Multiple Access interference (MAI) and Multipath Interference (MPI). Multipath effects are one of the major factors that limit system performance depending on the channel characteristics, in this paper the three paths effect was taken on DS-CDMA for ten users transmitted as baseband binary phase shift keying(BPSK) and the system assume synchronized.

Five users have maximal-linear code (127bits) and five users have gold code (127bits) in order to measure the difference between them, the code rate 8.125 MHz for each user with data rate 64Kb/s and the system was designed and simulated by using MATLAB-simulink version (6.5).

The probability of error (BER) was calculated for different cases of signal to noise ratio (E_b/N_0),the BER for maximal-linear code was 7.18×10^{-3} for where as for gold code was 4.375×10^{-4} at E_b/N_0 equal -2dB under three paths effect .

المستخلص:

أن أنظمة الاتصالات ذات نوع التتابع المباشر – تقسيم الترميز المتعدد (DS-CDMA) تمتلك عناية جديرة بالاهتمام خاصة للجيل الثالث لأنظمة ألاتصالات الخلوية. وهناك أنواع كثيرة من المعوقات وتداخل الإشارات ومن ضمنها الحزم الضيقة (NB) ،تداخل الترميز المتعدد (MAI) وتداخل المسارات المتعددة (MPI) .

تأثير المسارات المتعددة أحد العوامل الرئيسية التي تحدد أداء أنظمة الاتصالات والتي تعتمد على ميزات قناة الإرسال، في هذا البحث تم التركيز على تأثير ثلاث مسارات متعددة على DS-CDMA لعشرة مستخدمين والتي ترسل كحزمة قاعدية (baseband) للتضمين نوع (BPSK) وعلى فرض ان المنظومة متزامنة.

خمسة مستخدمين يملكون أقصى طول للترميز [maximal PN code (127bits)] وخمسة من المستخدمين يستخدمون الترميز الذهبي وذلك لغرض قياس درجة التباين فيما بينهما وان معدل الترميز هو 8.125MHz وسرعة إرسال البيانات 64Kb/s لكل مستخدم ولقد تم تصميم المنظومة بالاعتماد على برنامج المحاكاة (MATLAB- simulink).

تم احتساب معدل الخطأ في البيانات المستلمة (BER) وحالات مختلفة لنسبة الإشارة الى الضوضاء E_b/N_0 حيث وجد ان معدل الخطأ في البيانات هو 7.18×10^{-4} عند استخدام الترميز الذي يملك أقصى طول بينما كان معدل

⁺Received on 2/11/2008 ,Accepted on 20/1/2010 .

*Assistant Lecturer \ Collage of Electronics and Electric Technical

الخطأ في البيانات 4.375×10^{-4} عند الترميز الذهبي عندما تكون نسبة الإشارة إلى الضوضاء تساوي (-2dB) تحت تأثير المسارات المتعددة

Introduction:

In its generic form, direct-sequence code-division multiple access (DS-CDMA) is a spread-spectrum (SS) technique for simultaneously transmitting a number of signals representing information messages from a multitude of users over a channel employing a common carrier.

The method by which the various users share the channel is the assignment of a unique pseudo noise (PN)-type code to each user (which accompanies the transmission of the information) with orthogonal-like properties that allows the composite received signal to be separated into its individual user components, each of which can then be demodulated and detected. The deployment of the code (assumed to be represented by a binary waveform with PN properties) at the transmitter (*spreading process*, i.e., the superposition onto the binary information waveform) is accomplished by a simple multiplication [which is equivalent to modulo-2 addition of their (0, 1) representations], hence the term *direct-sequence* modulation. Similarly, the removal of the code at the receiver (*despreading process*) is also accomplished by the identical multiplication operation [1].

For our purposes in this paper, we assume that the receiver is perfectly capable of regenerating the transmitted codes corresponding to each of the users' transmissions, and as such we shall ignore all synchronization issues dealing with the acquisition and tracking of these codes at the receiver. A complete discussion of techniques for accomplishing these functions and their impact on system performance can be found in Part 4, Chapters 1 and 2, of Reference [2].

The DS-CDMA technique has its roots in the literature dealing with military network applications, where their use was primarily to combat intentional jamming introduced by an enemy. As such, the communication channel was typically modeled as additive white Gaussian noise (AWGN) combined with jamming of one sort or another. More recently, however, DS-CDMA has secured a strong foothold in the commercial market primarily because of its adoption as the IS-95 standard that governs digital cellular telephony in the all region of the world.

DS- CDMA system :

DS-CDMA can be divide into two types, single-carrier DS-CDMA and multiple-carrier DS-CDMA; in fact the second type is better than the first type for the fading channel along with the possibility of narrowband interference .In this paper we will deals with the first type which shown in figure (1) below [3, 4].the main parts of this system can be describe as follows:-

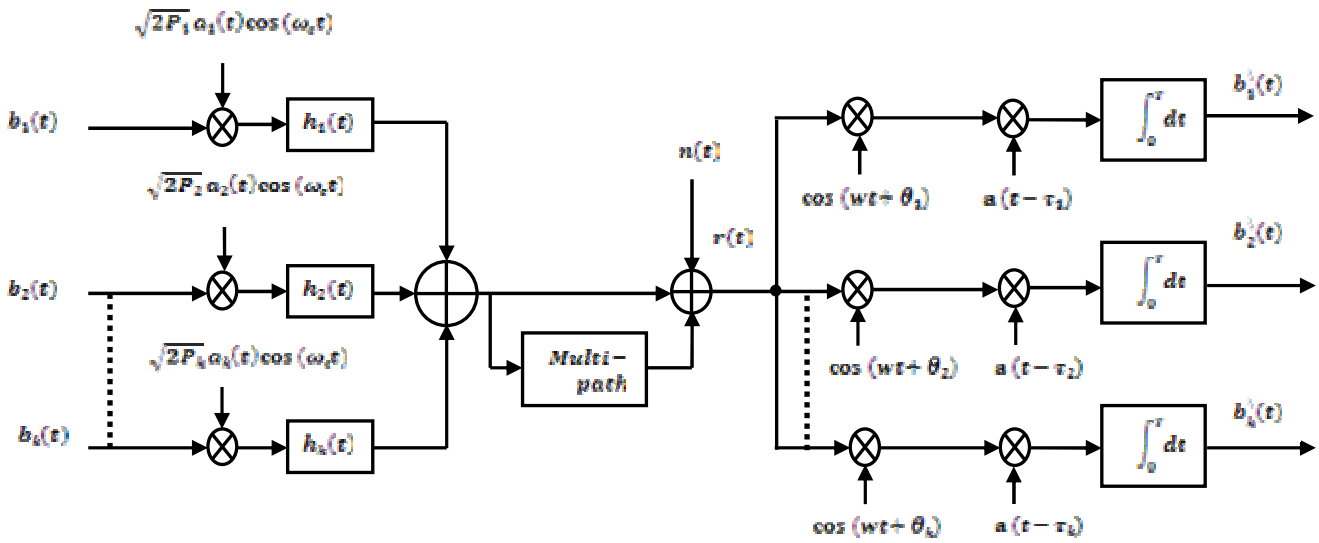

Fig. (1) DS-CDMA System Model.

1 Transmitted Signal

We consider a binary DS-CDMA system with K_u independent users sharing a channel simultaneously, each transmitting with power P at a common carrier frequency $f_c = \omega_c / 2\pi$, using a data rate $R_b = 1/T_b$ and a chip rate $R_c = 1/T_c$. The k th user, $k = 1, 2, \dots, K_u$, is assigned a unique code sequence $\{a_{k,j}\}$ of chip elements (+1,-1) so that its code waveform is given by [1]:-

$$a_k(t) = \sum_{j=-\infty}^{+\infty} a_{k,j} P_{T_c}(t - jT_c) \quad \dots \dots \dots (1)$$

Where the function $P_T(\cdot)$ denotes the chip pulse of duration T . In the single carrier case we assume that $P_T(\cdot)$ is a unit rectangular pulse. The code sequence $\{a_{k,j}\}$ is assumed to be periodic, with period equal to the processing gain $PG = T_b/T_c$. The data signal waveform $b_k(t)$ given by [1]:-

$$b_k(t) = \sum_{j=-\infty}^{+\infty} b_{k,j} P_{T_b}(t - jT_b) \quad \dots \dots \dots (2)$$

A binary phase-shift-keyed (BPSK) onto the carrier at f_c which is then spread by that user's code sequence and transmitted over the channel. The resulting k th user's transmitted signal $s_k(t)$ is thus given by [1]:-

$$s_k(t) = \sqrt{2P} a_k(t) b_k(t) \cos(\omega_c t) \quad \dots \dots \dots (3)$$

The composite transmitted signal $s(t)$ at the input of the channel can then be expressed as [1]:-

$$s(t) = \sum_{k=1}^{K_u} \sqrt{2P} a_k(t) b_k(t) \cos(\omega_c t) \dots \dots \dots (4)$$

2 Spreading Sequences:

All spread spectrum systems use one or more spreading codes to achieve spreading of the desired signal prior to transmission. Selection of spreading codes for a typical application depends on the application itself and on the specific properties of the spreading codes. For single user communications in a multipath environment the most important factor is to achieve the ability to resolve the multipath. To do this effectively, the spreading codes must have excellent autocorrelation properties, ideally a delta function. Similarly, for a multiuser system in a non-multipath environment the most important factor in selecting the spreading sequences is the ability to minimize the multi-access interference. The multi-access problem can be addressed if the spreading sequences are selected such that the maximum value of cross-correlation is minimized [5, 6]. Commercial CDMA systems are multiuser systems in multipath environment. Therefore, the spreading sequences for CDMA systems are selected by considering both their autocorrelation and cross-correlation properties. Furthermore, CDMA systems are cellular and require separation of intra-cell as well as inter-cell users. This requires two levels of spreading achieved by a combination of two spreading codes, referred to as channelization codes and scrambling codes. Multiple spreading is described in detail elsewhere [7]. Subsequent sections discuss the spreading sequences commonly used in commercial DS-SS systems and in our simulations as well.

1.1 Maximal Length Sequences:

Maximal length sequences or m -sequences are the most widely recognized and used pseudo noise (PN) sequences; they can be generated by two methods by using a linear feedback shift register (LFSR). The first using *simple* LFSR and the other use *modular* LFSR. Each of the LFSR, either simple or modular, can be represented by means of a polynomial [5].

A sequence, generated by an LFSR with m registers, is said to be a maximal length sequence or an m -sequence if its length is $L = 2^m - 1$. An m -sequence is generated when the LFSR structure represents a primitive polynomial [8,9]. The length of the m -sequence is the possible number of states an LFSR can take, except for an all zero state. For an LFSR, an m -sequence of length L provides the best autocorrelation properties [5,8], as follows:

$$R(n) = \left\{ \begin{array}{ll} 1 & n = 0, L, 2L, \dots \dots \dots \\ -1 & \text{otherwise} \end{array} \right\} \dots \dots \dots (5)$$

An example generation of an m -sequence using a simple LFSR is shown in figure (2). The same m -sequence can also be generated by a modular LFSR as shown in figure (3). The constructions in figure(2) and figure(3) are equivalent: they generate the same m -sequence, represent the same polynomial $1 + x^2 + x^5$, and implement the same difference equation

$x[i] = x[i - 2] \oplus x[i - 5]$. Another representation of both constructions is written as $[2 \ 5]_5 \equiv [3 \ 5]_M$. It should be noted that $[\]_5$ notation indicates the quotients of the primitive polynomial representing the LFSR while the $[\]_M$

notation indicates the quotients of a primitive polynomial that is the reciprocal of the primitive polynomial representing the LFSR. The construction used by Sarwate in [10] is similar to the simple LFSR but the representing polynomial is the reciprocal of the one representing the construction of simple LFSR in figure (3). Therefore, for our simulations, we implement the reciprocals of the polynomials given in proposed standards [11] using the structures of figure (2) and figure (3).

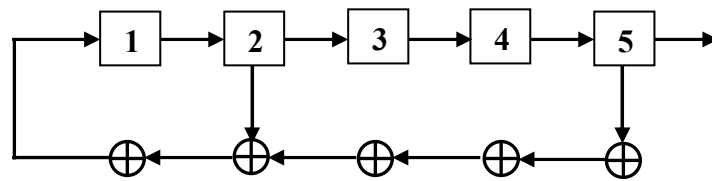

Fig. 2: Simple LFSR. Simple linear feedback shift register realization of a polynomial given by the difference equation $x[i] = x[i - 2] \oplus x[i - 5]$.

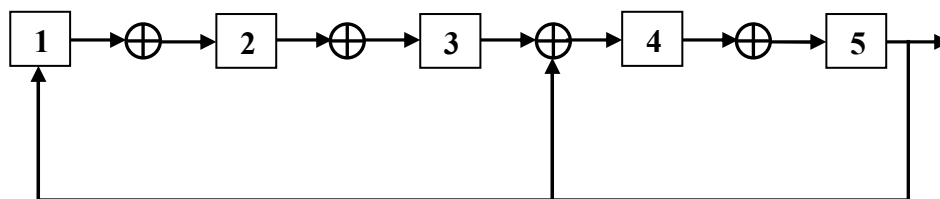

Fig. 3: Modular LFSR. Modular linear feedback shift register realization of a polynomial given by the difference equation $x[i] = x[i - 2] \oplus x[i - 5]$.

1.2 Gold Code

Gold code sequences are useful because a large number of codes (with the same length and with controlled cross correlation) can be generated, although they require only one pair of feedback tap sets. Gold codes are product codes achieved by the exclusive OR-ing (modulo-2 adding) of two maximum-length sequences with the same length (factor codes) as shown in figure (4). The code sequences are added chip by chip by synchronous clocking. Because the m-sequences are of the same length, the two code generators maintain the same phase relationship, and the codes generated are of the same length as the two base codes which are added together, but are no maximal (so the autocorrelation function will be worse than that of m-sequences). Every change in phase position between the two generated m-sequences causes a new sequence to be generated. Any 2-register Gold code generators of length L can generate $2^L - 1$ sequence (length $2^L - 1$) plus the two base m-sequences, giving a total of $(2^L - 1)$ sequences [12].

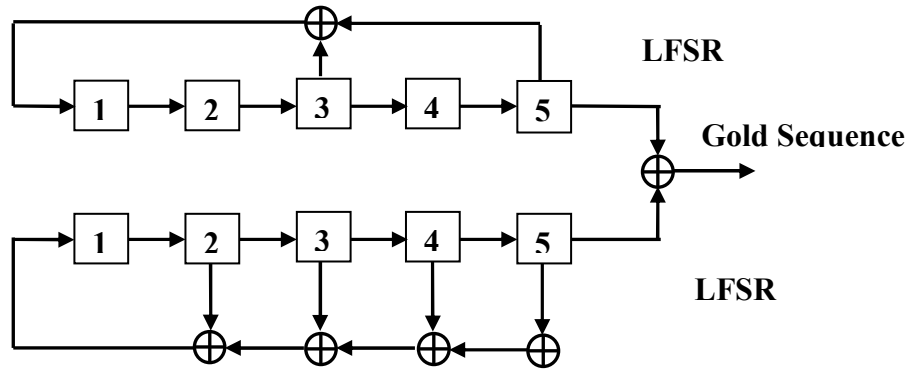

Fig.4: Block diagram of Gold code generation.

1.3 Multipath Fading Channels

Multipath occurs when signals arrive at the receiver directly from the transmitter and, indirectly, due to transmission through objects or reflection. The amount of signal reflection depends on factors such as angle of arrival, carrier frequency, and polarization of incident wave. Because the path lengths are different between the direct path and the reflected path(s), different signal paths could arrive at the receiver at different times over different distances [13].

One type of channel that is well suited to spread spectrum is the multipath fading channel. The complex baseband channel can be represented as [15]:

$$b(t, \tau) = \sum_{i=1}^L \alpha_i(t) e^{j(2\pi f_i t + \theta_i)} \delta(\tau - \tau_i) \dots \dots \dots (6)$$

Where α_i , f_i , θ_i and τ_i are the amplitude, Doppler shift, phase shift, and delay respectively associated with the i th path. Note that the amplitudes of the paths are typically assumed to be normalized such that the channel has unit average gain.

By modeling the channel as a linear system [14], the complex baseband version of the received signal $\tilde{r}(t)$ can be modeled as the convolution of the channel impulse response with the transmit signal [15]:

$$\tilde{r}(t) = s(t) \otimes b(t, \tau) + n(t) \dots \dots \dots (7)$$

Where $s(t)$ is the transmit waveform, $n(t)$ is AWGN, and $b(t, \tau)$ is the time-varying impulse response of the channel, which is typically modeled as a series of impulses [14].

In this paper ready model of AWGN with three path fading channel will be used from MATLAB simulink block set.

1.4 Receiver

With multipath propagation, it follows from equation (4) and equation (7) that the received signal $r(t)$, whose signal component is the time convolution of $s(t)$ and $h(t)$, may be written as[1].

$$r(t) = \sqrt{2P} \sum_{K=1}^{K_u} \sum_{i=1}^{L_p} a_{k,i} a_k(t - \tau_{k,i}) b_k(t - \tau_{k,i}) \cos[\omega_c(t - \tau_{k,i}) + \theta_{k,i}] + n(t) \dots (8)$$

Where $n(t)$ is the receiver AWGN random process.

In this paper the correlation receiver for K Users was used in a CDMA System as shown in figure (1). While correlation receivers are optimum in the AWGN channel, they have several vulnerabilities. The most important facet in a wireless environment is the resistance to multipath. Here correlation receivers treat multipath reflections as noise degrading the signal because the multipath components are decorrelated with the primary component. DS/SS systems are more resistant to multipath than other modulation types because of the low autocorrelation value of PN sequences. Correlation receiver performance also degrades substantially in a CDMA environment when interfering signals have a larger signal energy than the desired signal, i.e., near-far problem.

Near-far effects will always be present in a wireless CDMA environment because time-varying channels make ideal power control impossible. Multipath and near-far effects have motivated the development of receiver structures that are resistant to both these conditions [4].

System design:

The DS-CDMA is designed by using MATLAB - simulink version (6.5) as shown in figure (5), because it is an attractive simulation tool that provides the designer many facilities to rapidly design, implement and test the desired system. Also it gives the designer a clear imagination to the system parameters which is required to complete the design. The waveforms and spectra at any point of design can be obtained by using scope or frequency spectrum, this is very necessary to check the design. The system was assumed synchronous and it has the following specification:-

- 1- Ten users each user have data rate: 64Kb/s.
- 2- Ten different PN code with code rate 8.125MHz at lengths 127 bits, five PN code are maximal linear code (user1 – user5) and five PN code are Gold code (user6 – user10).
- 3- Modulation type: baseband BPSK.
- 4- Three path propagation for each user in microsecond.
- 5- All ten users transmitting at the same time over the same channel.
- 6- Processing gain for each user:-

$$G_p = \frac{Bw_{RF}}{Bw_{data}} = \frac{clock\ rate}{data\ rate} = \frac{8.125MHZ}{64KHZ} = 126.953$$

$$\therefore (G_p)_{dB} = 10 \log 126.953 = 21dB.$$

Ten user DS-SS-SS-SS with BPSK modulation

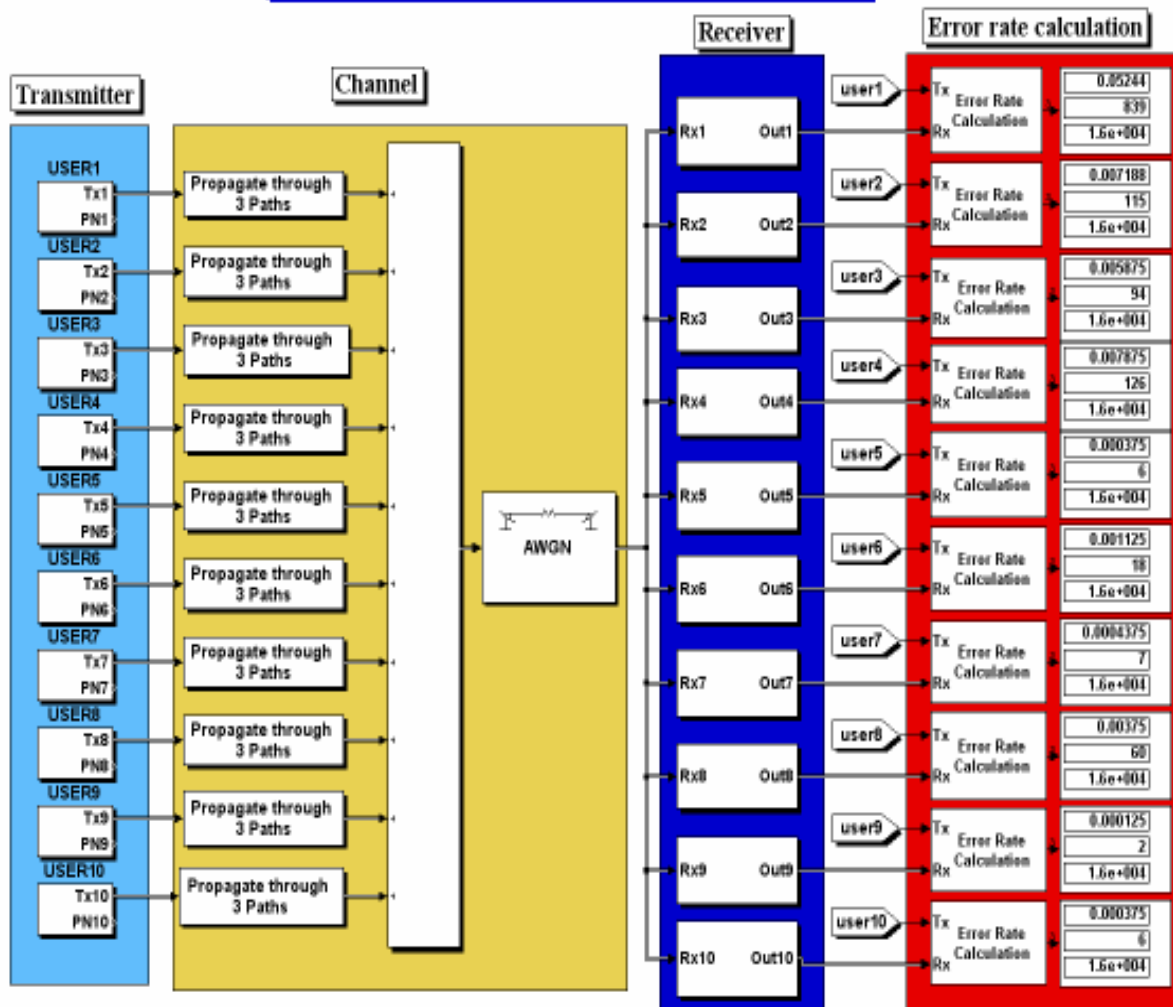

Fig.5: Block diagram of ten users for DS-SS-SS-SS system

Each transmitter and receiver for the ten users contains the parts as shown in figure (6) and figure (7) respectively.

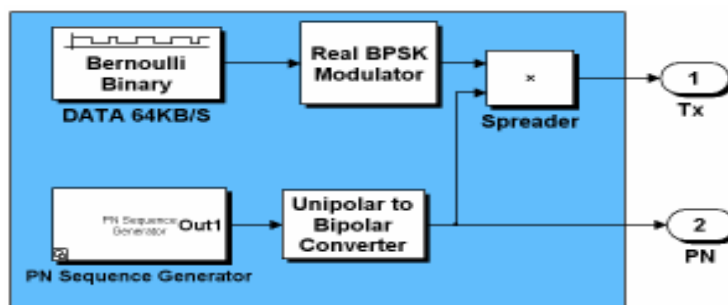

Fig.6: Block diagram of the transmitter unit.

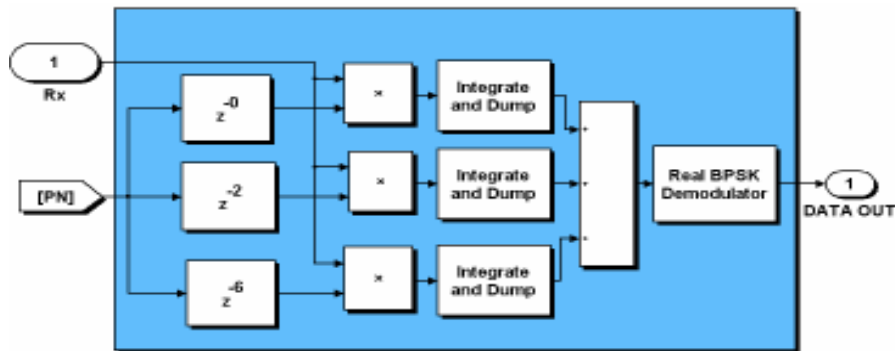

Fig.7: Block diagram of the receiver unit.

Results:

The system was simulated at 6400 bit under the multi-path effect (three paths) and Additive White Gaussian Noise (AWGN) for different cases of signal to noise ratio E_b/N_0 . If E_b/N_0 equal 0dB was taken from AWGN block set with three path effects, the autocorrelation and crosscorrelation between transmitted and received PN code for maximal-linear code was shown in figure (8) and figure (9) respectively. In the same conditions the autocorrelation and crosscorrelation between transmitted and received PN code for gold code was shown in figure (10) and figure (11) respectively.

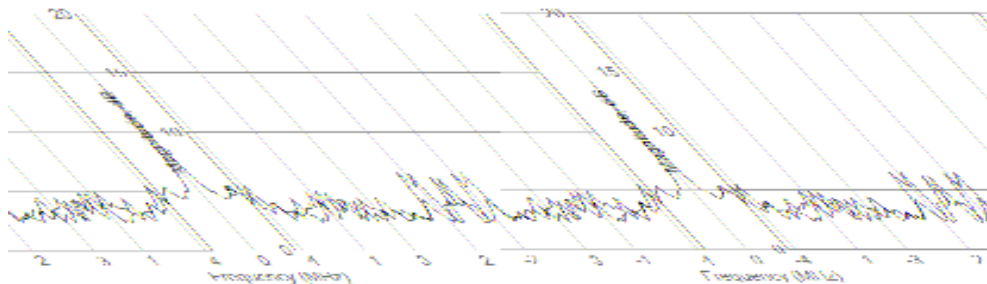

Fig.8: Autocorrelation between transmitted and received PN code for maximal-linear code.

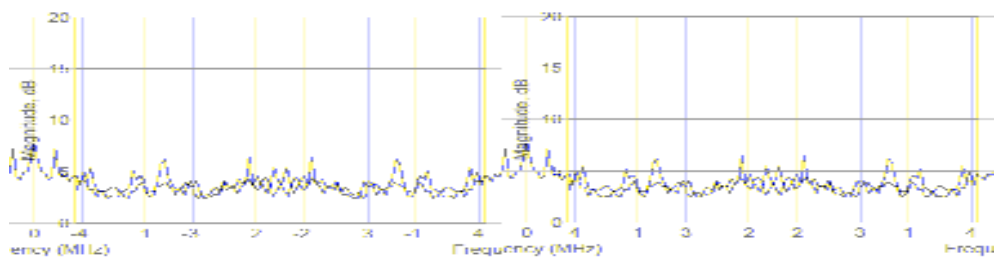

Fig.9: Crosscorrelation between transmitted and received PN code for maximal-linear code.

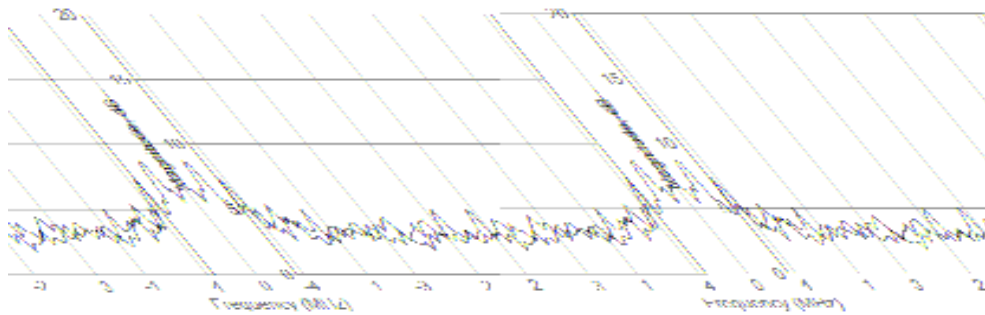

Fig.10: Autocorrelation between transmitted and received PN code for gold code.

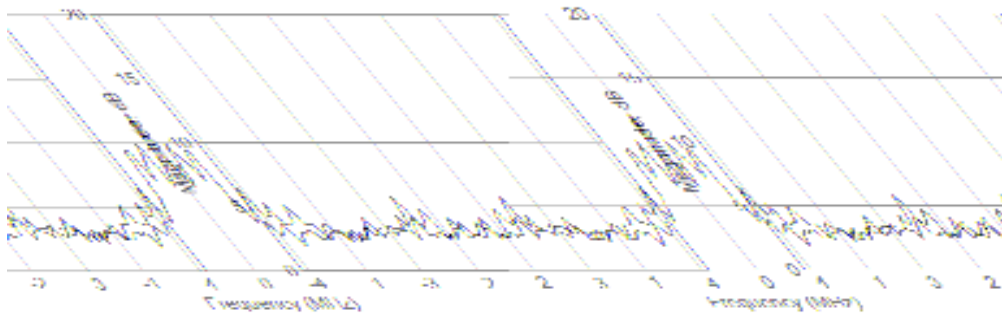

Fig.11: Crosscorrelation between transmitted and received PN code for gold code.

The waveform of the transmitted and received data for two users as example (user2 which used maximal –linear code and user7 which used gold code) was shown in figure (12) below.

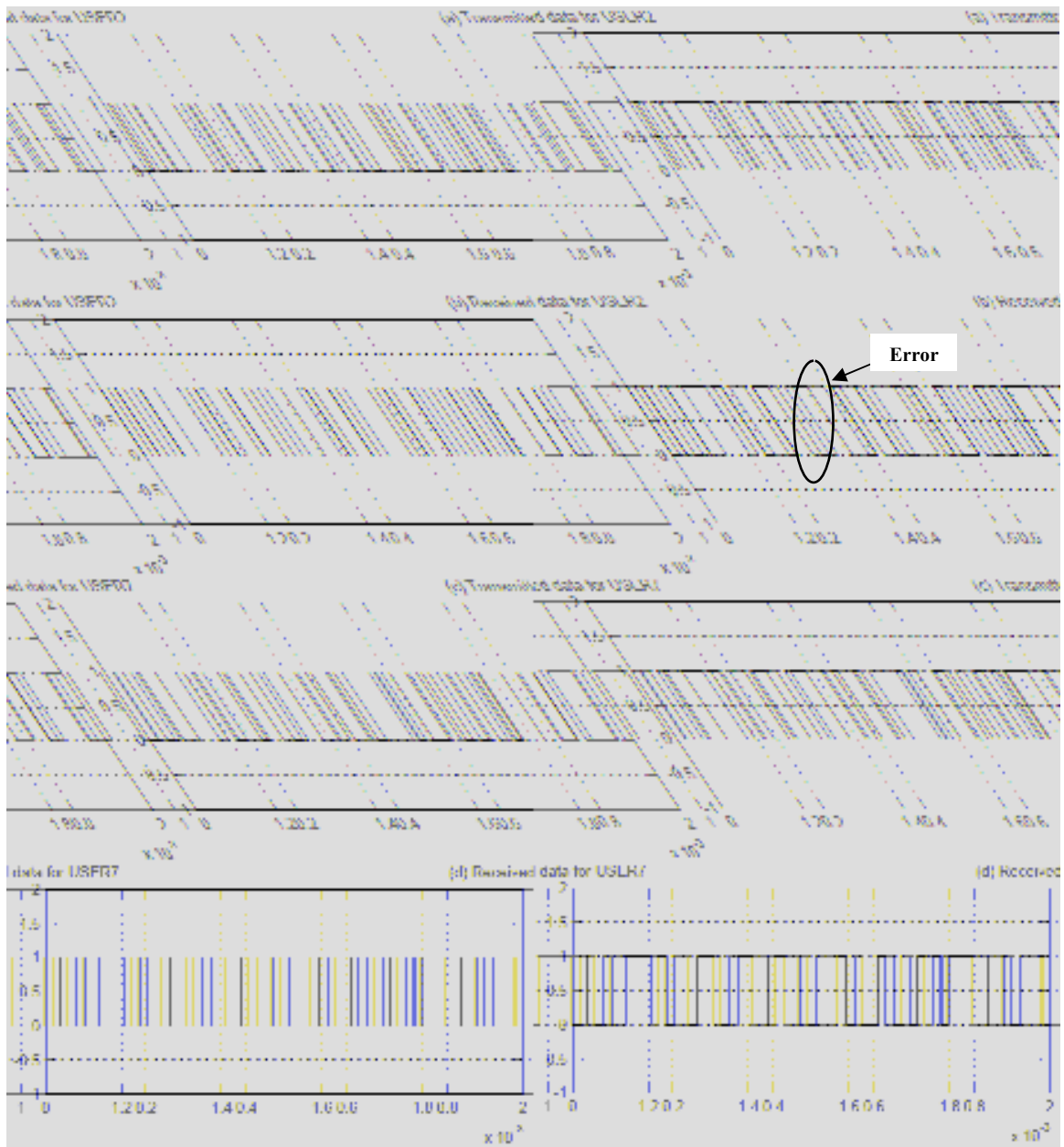

Fig.12: Waveform of (a) and (b) transmitted and received data respectively for user2 (c) and (d) transmitted and received data respectively for user7.

Now to prove the performance of the system, the probability of error (P_e) must be calculate from error rate calculation block for each user for different cases of E_b/N_o ratio which selected from AWGN block set, after 6400 bits simulation processor the result was shown in figure (13) which shows the relationship between the probability of error versus the E_b/N_o ratio for ten users with three path effect.

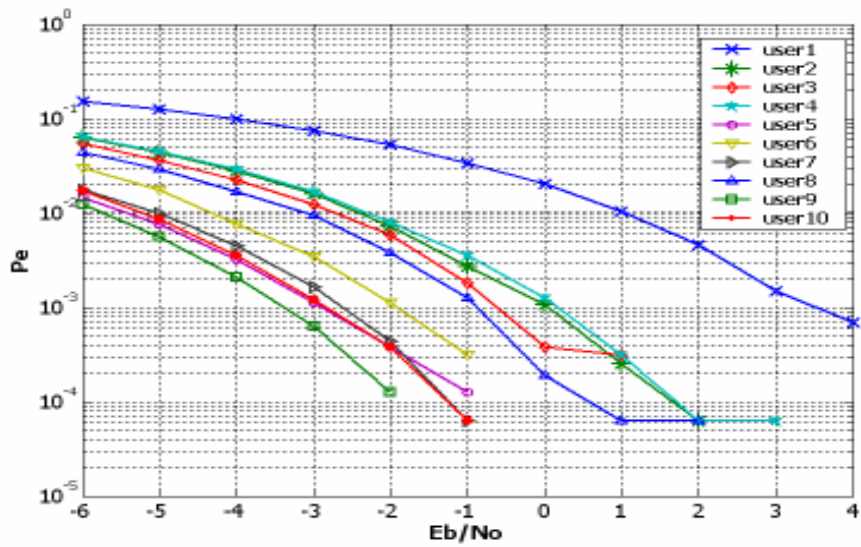

Fig.13: The probability of errors versus E_b/N_o for ten users with three paths effect.

For comparing the probability of error between the users which used maximal-linear code and the users used gold code , four users was taken (user2 , user4 ,user7 and user10) as shown in figure(14) below which shows the relationship between the probability of error versus the E_b/N_o with three paths effect.

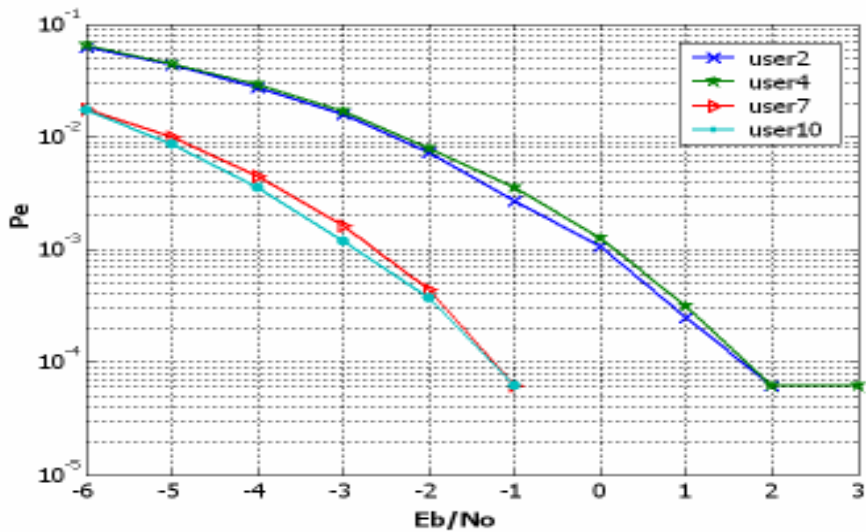

Fig.14: The probability of errors versus E_b/N_o for four users.

Conclusion:

Figure (11 a and b) shows the waveform of the transmitted and received data for user2 which used maximal – linear code, figure (11 c and d) shows the waveform of the transmitted and received data for user7 which used gold code, it is clear that the user7 had better performance than user2, this means using gold code in DS-CDMA system better than using maximal-linear code.