

FREQUENCY OFFSET EFFECT ON THE PERFORMANCE OF CHAOTIC CHIRP SPREAD SPECTRUM SYSTEM⁺

تأثير الانحراف في التردد على أداء منظومة طيف منتشر تستخدم الإشارة العشوائية وإشارة التعديل

التردد الخطي

Mohamed. S. Haji Ali *

Maan M. Shaker**

Thair A. Salih***

Abstract:

Recently there has been a great deal of interest in the application of spread spectrum systems. However, the performance of the robust spread spectrum system detector depends on the selection of the spreading signal. This paper is intended to provide the basic concepts of a proposed spread spectrum system based on two features. The first one implies the use of the spread spectrum based on Rossler chaotic sequence to minimize interference caused by other systems to secure the information transmission. The second concept clarifies the use of a chirp signal to achieve high data transmission rate within a limited bandwidth. Furthermore, performance of the proposed system is simulated in the presence of AWGN as well as frequency offset is applied to notice and limit its effect. Bit error rate (BER) is computed to evaluate the system confidentiality.

Keywords- chirp, chaotic, QPSK, spread spectrum

المستخلص:

لقد زاد اهتمام العلماء في الآونة الأخيرة لاستخدام منظومات الطيف المنتشر في التطبيقات المختلفة. على أية حال يعتمد أداء منظومات الطيف المنتشر الموثوقة على اختيار مواصفات الإشارة المنتشرة. يقدم هذا البحث المفهوم الأساسي لمنظومة طيف منتشر تعتمد في بناءها على استخدام إشارة عشوائية نوع (Rossler) كإشارة منتشرة لغرض تقليل التداخل الناجم عن تأثير المنظومات الأخرى للحصول على وسيلة إرسال معلومات ذات سرية تامة، إضافة إلى استخدام إشارة (Chirp) للحصول على إمكانية إرسال كم هائل من المعلومات خلال حزمة ترددية محددة. تم تقييم أداء المنظومة المقترحة من خلال حساب نسبة معدل الخطأ في المعلومات المرسله تحت تأثير (Frequency Offset) والضوضاء الأبيض الكاوزي المضاف (AWGN) باستخدام برمجيات (Matlab/Simulink).

Introduction:

When a signal is propagated through a wireless channel, it should be disturbed by impairments such as fading, multipath spread, adjacent channel interference, and other effects. Spread spectrum (SS) technique is known as a technique being strong against these impairments and maintaining required system performance in such a bad channel environment. Therefore, systems based on the spread spectrum technique are well suited for wireless communication [1]. The spread spectrum signal is not easily detected since it appears

⁺ Received on 22/4/2009 ,Accepted on 13/12/2009.

* Prof / Aleppo University .

** Ass . Prof / Technical College /Mosul .

*** Lecturer/ Technical College /Mosul .

to be noise-like except at the intended receiver where the spreading sequence is known. SS systems can strongly reject narrowband interference and they fail in rejecting wideband interference [2]. In 2005, a proposal based on chirp spread spectrum (CSS) was proposed for IEEE802.15TG4a by Nanotron Technologies. Chirp signals and the associated technique of pulse compression which is extensively used in radar systems are well suited for spread spectrum transmission. Because of its advantages such as high processing gain, large bandwidth, low power, scalable bit rate, robustness to multipath interference, immunity to Doppler frequency offset, and others. CSS techniques have been applied to many areas [3]. Chirp signal, chirp modulation, or linear frequency modulation for digital communication was patented by Sidney Darlington in 1954 with significant work performed by Winkler in 1962. This type of modulation employs sinusoidal waveforms whose instantaneous frequency increases or decreases linearly over time. These waveforms are commonly referred to as linear chirps or simple chirps [4]. Chirp signals has the wave form which can be written as:

$$S(t) = a(t) \cos(2\pi f_o t + \pi \mu t^2) \quad (1)$$

where $a(t)$ is the envelope of chirp signal and $a(t) = 0$, when $|t| \geq \frac{T}{2}$; f_o is the starting frequency; μ is the rate of frequency change. $\mu > 0$ makes an up-chirp while $\mu < 0$ makes a down-chirp. Within a period of $0 \leq t < T$, up-chirp and down-chirp signal can be written as.

$$\begin{aligned} c_1(t) &= a(t) \cos(2\pi f_o t + \pi \mu^2) \\ c_2(t) &= a(t) \cos(2\pi f_o t - \pi \mu^2) \end{aligned} \quad (2)$$

The transmitted signal is:

$$s(t) = b c_1(t) + (1-b) c_2(t) \quad (3)$$

where b is the bit ready to be sent. The received signal is composed of transmitted signal and AWGN [5].

$$r(t) = s(t) + n(t) = b c_1(t) + (1-b) c_2(t) + n(t) \quad (4)$$

The impulse response of a filter matched to a chirp signal is also a chirp but with opposite sign of μ . If $a(t)$ is a rectangular function, the autocorrelation function of a linear chirp, or the output of a chirp passing a matched filter, can be written as:

$$g(t) = \sqrt{\frac{\mu}{2\pi}} \cos(\omega_o t) \frac{\sin\left(\frac{\mu t(T-|t|)}{2}\right)}{\mu t}, \quad -T < t < T \quad (5)$$

if the expression at $2\omega_o$, is neglected, which is reasonable for most cases of practical interest. $g(t)$ is with the form of $(\sin x)/x$, a SINC function. SINC function has the property of high autocorrelation peak and low side lobes. Due to this high autocorrelation peak, CSS has a very large processing gain. Furthermore, the output energy of other signals, such as noise, of the matched filter is spread in time.

It is widely accepted that CSS is immune to Doppler frequency offset. If a chirp signal with the form of Eq.(1) (where $a(t)$ is a rectangular function) has reached the receiver with a certain frequency offset $\varepsilon = \omega_d / 2\pi$ then the received signal can be represented as :

$$f(t) = \cos[(\omega_o + \omega_d)t + \frac{\mu t^2}{2}], \quad -\frac{T}{2} < t < \frac{T}{2} \quad (6)$$

The output of the matched filter is:

$$G(t, \omega_d) = \sqrt{\frac{2\mu}{\pi}} \cos[(\omega_o + \frac{\omega_d}{2})t] \cdot \frac{\sin[\frac{\omega_d + \mu}{2} (\frac{T}{2} - |t|)]}{\omega_d + \mu t}, \quad -\frac{T}{2} < t < \frac{T}{2} \quad (7)$$

Comparing Eq.(5) with Eq.(7), we can see that the two outputs has the same form of a SINC function except for a time shift of the autocorrelation peak, which can be represented as[6]:

$$\delta_t = \frac{\varepsilon}{\mu} \quad (8)$$

CSS is classified into two types according to how to modulate chirp signals with information data. One is binary orthogonal keying (BOK) and the other is direct modulation (DM). BOK uses up-chirps for representing bit '1' and down-chirps for representing bit '0'. Thus both up and down-chirp filters exist together at transmitter and receiver in BOK. On the other hand, DM uses the chirp signal as a spreading code which is similar to a pseudo random (PN) sequence in direct sequence spread spectrum. Modulation and demodulation are performed separately and independently from the chirp processing in DM. Thus, the system using DM requires only one chirp filter at each transmitter and receiver [1]. The advantages of using chirp spread spectrum over other modulation techniques include reduction of complexity, increased robustness and lower cost. Many advantages of CSS have over other spread spectrum techniques are: 1-its ability to tolerate large frequency drifts, 2- its analog-only implementation, 3-its robustness to transmitter-receiver frequency offsets. Such offsets can be caused by Doppler shifts in the channel, oscillator drift and other factors [7].

Chaotic communication can be considered as a spread spectrum communication, which spreads a message signal into a much wider bandwidth in comparison with the message signal. The message signal is then retrieved at the receiving end by coherent or non-coherent despreading and demodulation [8]. Chaos, as a particular nonlinear dynamic phenomenon, lies in some special continuous nonlinear equations or discrete nonlinear maps [8]. Many advantages can be shown when chaos is applied to communication system. Firstly, chaos can be easily generated by some simple nonlinear equations. Secondly, it is sensitive to initial conditions and has noise-like, wideband spectrum features. These good merits make us easily construct a number of periodic and non-correlated sequences, which are candidates for conventional PN codes. The conventional PN sequence, such as m sequence, has good auto-correlation property, but spikes are usually found in its cross-correlation function. Furthermore, they can make the communication system more secure [9]. In 1963, Lorenz found the first classical chaotic attractor. In 1999, Chen and Ueta found another chaotic attractor, which is similar, but not topologically equivalent to the Lorenz attractor. In 2002, Lu and Chen also found the critical attractor between the Lorenz and Chen attractor [10]. A number of chaotic communication schemes have been proposed, such as chaos masking, chaos shift keying and chaotic modulation [8]. Chaotic communication is implemented instead of the conventional communication system, since messages were successfully sent at some gigabit per second (Gbps) speeds (v) over a distance $R=115$ km of commercial optical fiber system with a BER of one in ten million. The BER is said to be limited by the equipment rather than the technique itself. The advantage is that at such a high speed, it is easier to generate strong, high-power chaotic signals than periodic signals [11].

Chaotic sequence has many of the properties such as [12]:

- a- Balance Property
- b- Correlation Property
- c. Security

Several modulating schemes have been used in chaotic communications. The most common ones are [11]:

- Chaos Shift Keying (CSK);
- Differential Chaos Shift Keying (DCSK);
- Additive Chaos Modulation (ACM);
- Multiplicative Chaos Modulation (MCM).

System Model

Fig. 1 shows configurations of both transmitter and receiver blocks, respectively and the system parameters were illustrated in table (1).

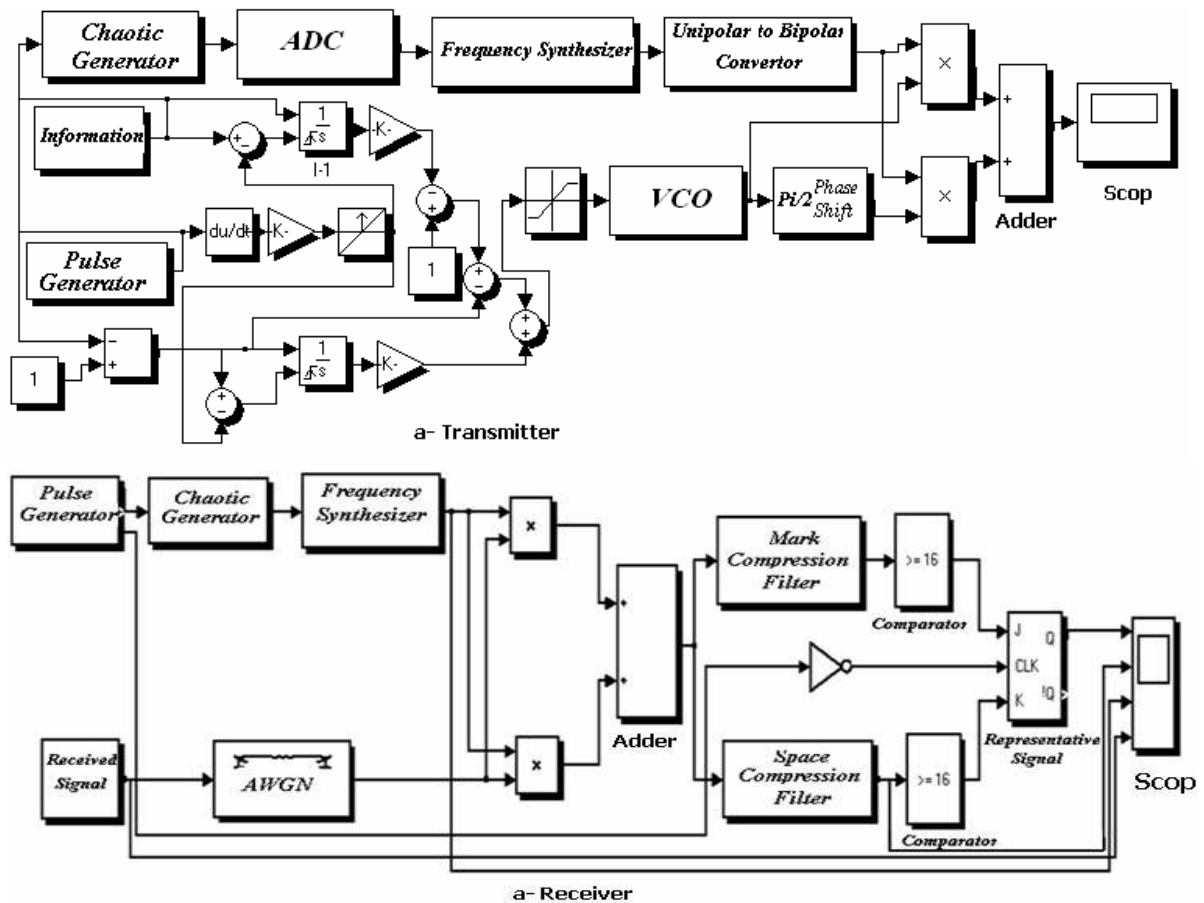

Fig. 1. The proposed system simulator.

Table (1): System parameters

Data signal	20 KHz
Chirp signal	$T=0.5\mu\text{sec}, \mu=150\text{KHz}, f_0=5\text{KHz}$
Spreading signal	(14.06-16.9)MHz
Transmitted signal	(14.28-17.29)MHz

On the transmitter side, the binary data are used to generate the chirp signal with positive or negative slope. The proposed system uses Voltage Controlled Oscillator (VCO) to generate the chirp signal. By employing the VCO, the chirp signal can be easily obtained without using any complex devices. The Rossler map is recommended here as the spreading code generator, due to its favorable correlation properties. The Rossler system has a smooth attractor with a nearly uniform distribution which is important for reliable synchronization and optimal usage of the frequency bandwidth. The system can be written in the form:

$$\begin{aligned}
 \dot{X}_1 &= \mu(-X_2 - X_3 - d) \\
 \dot{X}_2 &= \mu(2.25X_1 + 0.15X_2) \\
 \dot{X}_3 &= \mu(0.04 + 5X_3(X_1 - 2))
 \end{aligned} \tag{8}$$

where X_1 , X_2 and X_3 are the states of the system, μ and d are fixed parameters [13].

Owing to the spectrum efficiency and the constant envelope, QPSK modulation is utilized in the proposed system to modulate the chirp signal. Traditionally, a double balance modulator and a 90° phase shifter are usually employed to implement a QPSK modulator. In QPSK, two bits are transmitted in a signal modulation symbol in stead of one bit as for BPSK. Thus, the bandwidth efficiency of QPSK is twice that of BPSK. This is because the main lobe of the power spectral density of a QPSK signal is equal to twice the symbol rate, which is half that of BPSK. When the transmission signal passes through the AWGN channel, the received signal is: $Y_{\text{out}} = S(t) + N(t)$.

At the receiver (with proper synchronization between the transmitter and receiver is proposed) the transmitted signal is correlated with an identical spreading signal included at the receiver and then is filtered out to retrieve the chirp signal. The chirp signal is fed into the matched compressor filters. The up-chirp filter is matched to the '0'-bit signal, the down-chirp filter is matched to the '1'-bit signal. Pulse compression filter employs a modulated "long" pulse to achieve the range resolution of a "short" pulse without the need for high peak transmit power. JK flip flop is used to reconstruct the original data.

SIMULATION RESULTS:

System simulation is performed to validate the feasibility of the proposed system using Matlab and Simulink. The output signals such as the original data signal, the chaotic signal, the spread signal, and the QPSK signal, are all shown in Fig.(2) and Fig.(3). Notice that the final receiver data signal is an exact replica of the one being transmitted except small delay. The proposed system is based on QPSK demodulation, and it is assumed that chaotic generators are synchronized with the signal for simplicity, because synchronization issues are beyond the scope of this paper. AWGN is a real problem when operating with the proposed system. Fig. (4) shows the matched filter output signals in the presence of AWGN.

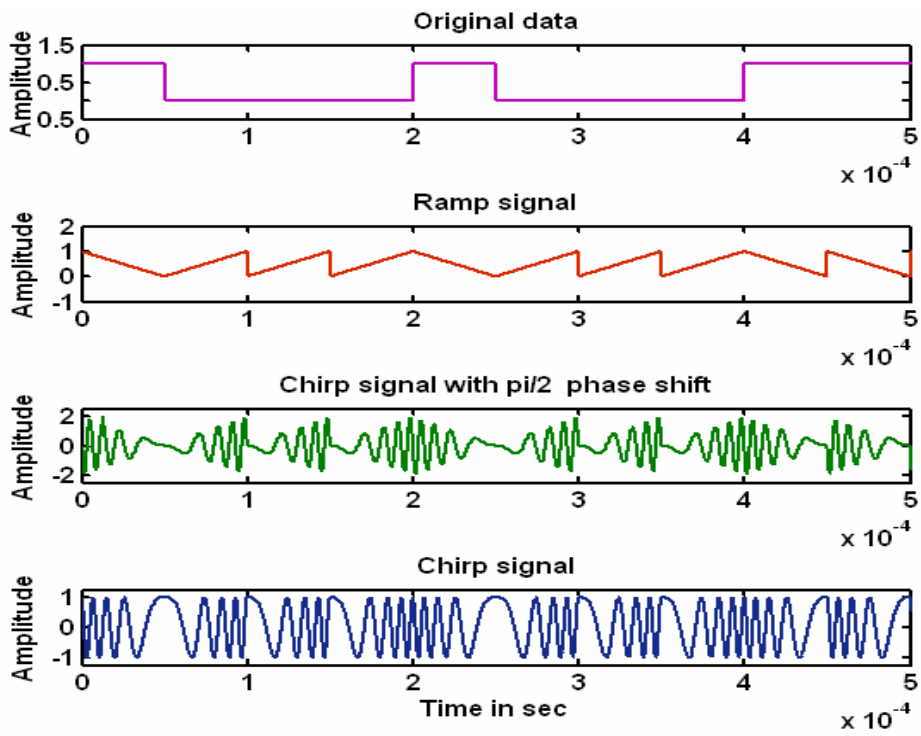

Fig. 2. a- Original Data, b- Ramp Signal, c- Chirp Signal with Pi/2 Phase Shift, d- Chirp Signal.

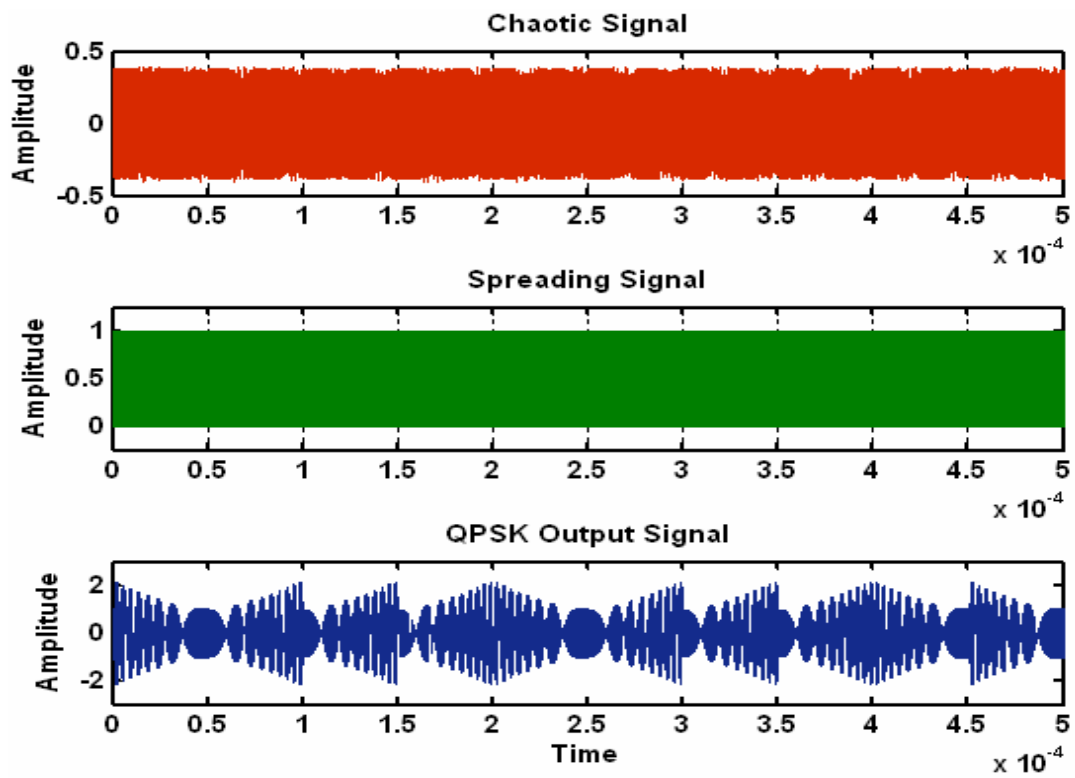

Fig. 3. a- Chaotic Signal, b- Spreading Signal, c- QPSK Signal.

One of the most important characteristics of a communication system performance evaluation is the bit error rate as a function of the signal to noise ratio or the ratio of energy per bit to the noise spectral density E_b/N_0 . It provides a quantitative measure for the efficiency of the modulation-demodulation scheme used in the system. The simulation is carried out to show the system performance under the effect of frequency offset. The "frequency/phase offset" block is used in Simulink to add frequency offset, as shown in Fig. (5).

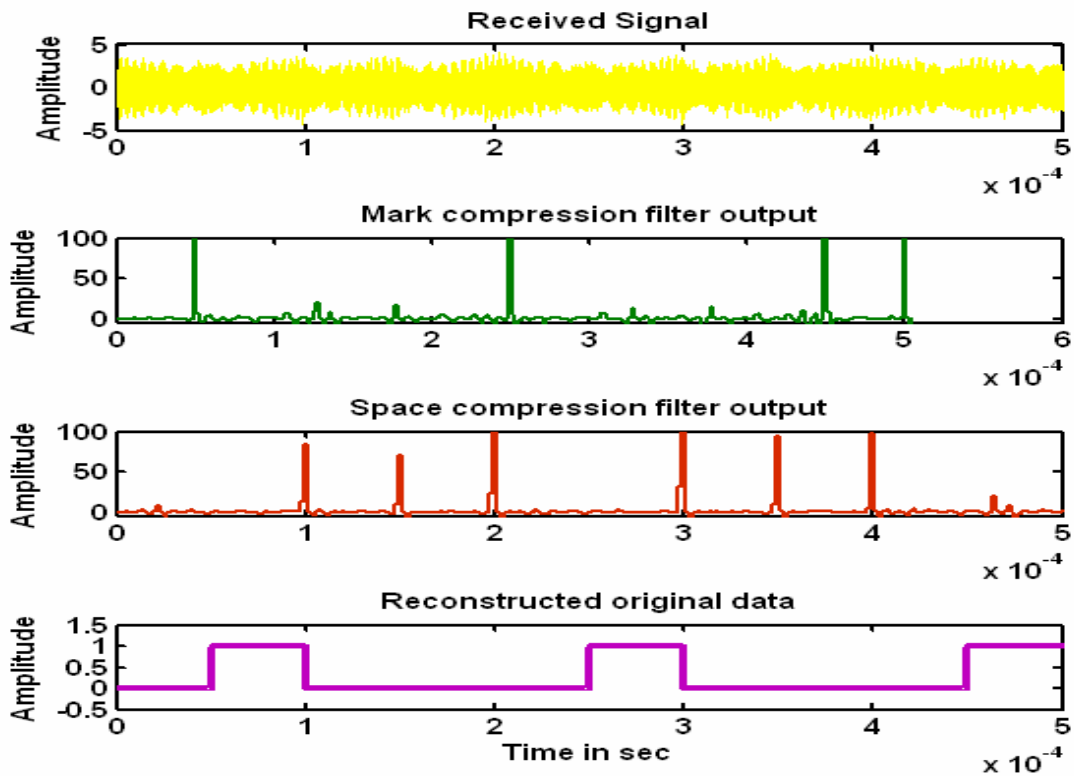

Fig. 4 a- Received Signal- Mark Compression Filter, c- Space Compression Filter, d-Reconstructed Original Data.

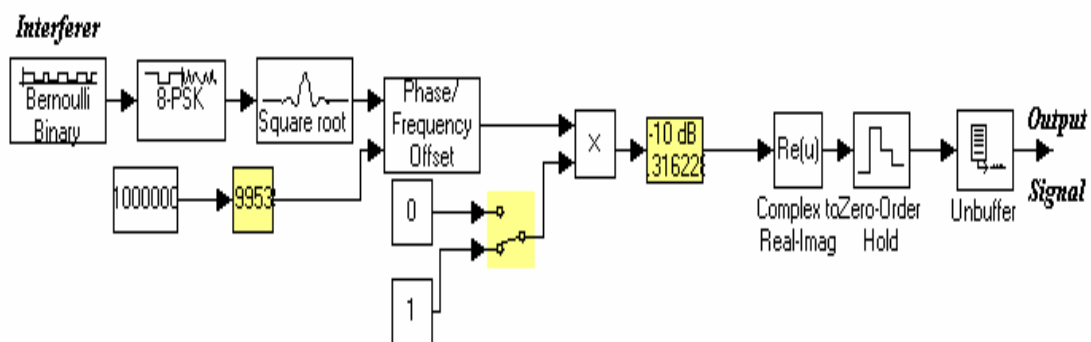

Fig. 5. Frequency/phase Offset Generator.

To get a high impression how robustness appear in the proposed system, Fig.(6) shows the BER with different frequency offset values. From Fig.(6) the BER is the same as the theoretical one (with no frequency offset) when the frequency offset is 10 kHz or 1MHz. For frequency offset equals to 100 kHz (the frequency offset value approaches the center frequency of the chirp signal), that system performance would have high BER.

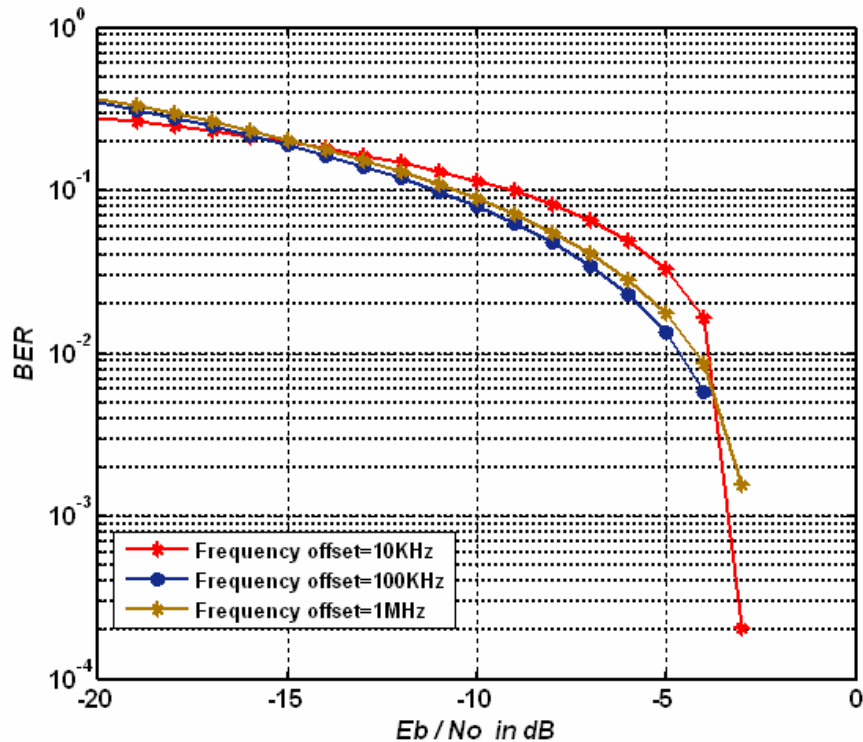

Fig. 6. BER of the proposed system.

CONCLUSIONS:

This paper presents a Simulink model for designing a robust spread spectrum system based on a chaotic and chirp signals. The proposed system can combine efficiently the techniques of chirp system, chaotic system and QPSK. Through analysis and simulation of the system, it is shown that under the best channel condition (AWGN only), the system is immune to Doppler frequency offset. In this scheme, chaotic sequences are generated by the proposed Rossler map with different parameter sets to carry the corresponding binary bits packets. The results show that the designed system has a simpler structure and thus is relatively easier to be realized.

References:

1. Taeung Y., Sangho A., Sun Y. K., and Seokho Y., "Performance Analysis of an Overlap-Based CSS System", *IEEE 10th International Conference on Advanced Communication Technology*, Vol. 1, pp. 424 – 426, Feb. 2008.
2. Z., Nandini A., Sridhar K. and Alagan A., "Interference Detection in Spread Spectrum Communication Using Polynomial Phase Transform," *IEEE International Conference on Communications*" pp.2979 – 2984, June 2007.
3. Chenglin Z., Fangmin X., and Zheng Z., "Frequency-Band Coded Orthogonal UWB Pulse Design Based on Chirp Spread Spectrum for Cognitive NBI Suppression", *IEEE Military Communications Conference*, pp.1-6, Oct. 2007.
4. Eui S.K., Jin I. K., Ik-Seon K., Chan G. P. , and Jang G. L., "Simulation Results of Ranging Performance in Two-ray Multipath Model", *IEEE International Conference on Control, Automation and Systems*", pp.734-737, Oct. 2008.

5. Xiaowei W.X. L. M. F., " Performance Evaluation of Wireless Networks Based on Chirp Spread Spectrum", *IEEE 11th International Conference on Communications Technology*, pp.58-61, 2008.
6. Peng Z.and Hao L., " An Ultra-Wide Band System with Chirp Spread Spectrum Transmission Technique," *International Conference on ITS Telecommunications*, pp. 294-297, 2006.
7. John P., " Low Complexity Indoor Wireless Data Links using Chirp Spread Spectrum". *PhD. Dissertation, Electrical and Computer Engineering Department, Faculty of Graduate Studies, University of Calgary, June 2007.*
8. Shiyuan W. and Jiuchao F., " Particle Filtering for Noisy Contaminated Chaotic Signals and Its Application in Communications", *IEEE International Conference on Control and Automation*, pp. 524-528, June 2007.
9. Hongmin D., Tao L., Qionghua W.and Hongbin L., " A Novel Chaotic Slow FH System Based on Differential Space-Time Modulation", *IEEE International Conference on Embedded Software and Systems Symposia*", pp.380-385, 2008.
10. M., Yongguang Y., Guoguang W. and Rongguang C., " Chaos Synchronization of Unified Chaotic System Using Fuzzy Logic Controller", *IEEE International Conference on Fuzzy Systems*, pp.545-547, 2008.
11. Anjam R.and Maaruf A., " Chaotic Communications, their Applications and Advantages over Traditional Methods of Communication", *IEEE 6th International Symposium on Communication Systems Networks and Digital Signal Processing*, pp.21-24, July 2008.
12. Junrong G., Jae H. H., Ning H., and Jae M. K., " Analysis of an Interleaved Chaotic Spread Spectrum Sequence", *IEEE 8th International Conference on Wireless Communications Networking and Mobile Computing*, Oct. 2008.
13. A. R. Volkovskii, a_ L. Sh. Tsimring, N. F. Rulkov, and I. Langmore, " Spread spectrum communication system with chaotic frequency modulation", *Chaos*, Vol. 15, Issue 3, pp. 033101-033101-6, July 2005.