



Non-Human-Machine Interaction for Power Transmission Lines Protection Design and Enhancement of Under Voltage Relay

Abadal-Salam T. Hussain

Department of Medical Instrumentation Engineering Techniques, Al-Kitab University,
Altun Kupri, Kirkuk, Iraq.
asth3@yahoo.com

Citation: Hussain A.S. Non-Human-Machine Interaction for Power Transmission Lines Protection Design and Enhancement of Under Voltage Relay. Al-Kitab Journal for Pure Sciences (2021); 5(2): 26-40 .DOI: <https://doi.org/10.32441/kjps.05.02.p3>

Keyword

Voltage relay, Transmission line protection relay Under-voltage Fault types and fault location.

Article History

Received	03 Apr. 2021
Accepted	07 June. 2021
Available online	31 Dec. 2021

©2021. Al-Kitab University. THIS IS AN OPEN ACCESS ARTICLE UNDER THE CC BY LICENSE
<http://creativecommons.org/licenses/by/4.0/>



Abstract:

The continuous monitoring of transmission line protection relay is desirable to ensure the system disturbance such as fault inception is detected in transmission line. Therefore, fault on transmission line needs to be detected, classified, and located accurately to maintain the stability of system. This project presents design enhancement and development under voltage relay in power system protection using MATLAB/Simulink. The under-voltage relay is a relay that has contacts that operate when voltage drops below a set voltage which is used for protection against voltage drops to detect short circuit and others. This study is carried out for all types of faults which only related with one of the parallel lines. For the overall of operation conditions, the sample data were generated for the system by varying the different fault types and fault location. This design system proposes the use of MATLAB/ Simulink based method for fast and reliable fault classification and location for a various type of fault.

Keywords: Voltage relay, Transmission line protection relay, Under-voltage Fault types and fault location.

تصميم وحماية تلقائي من غير تدخل الانسان لخطوط نقل الطاقة وتحسين مرحل الجهد المنخفض

عبد السلام طه حسين

قسم هندسة تقنيات الأجهزة الطبية، الكلية التقنية الهندسية، جامعة الكتّاب

الخلاصة:

من المرغوب فيه المراقبة المستمرة لترحيل وحماية خط نقل الطاقة من غير تدخل الإنسان لضمان اكتشاف اضطراب النظام مثل بدء الخطأ في خط النقل. لذلك، يجب اكتشاف الخطأ في خط النقل وتصنيفه وتحديد موقعه بدقة للحفاظ على استقرار خطوط نقل الطاقة من خلال التمثيل الرياضي قبل التنفيذ الحقيقي للخطوط الناقلة للطاقة. يقدم هذا المشروع تحسيناً وتطويراً للتصميم تحت ترحيل الجهد في حماية نظام الطاقة باستخدام تطبيق ما تلاب نظام التمثيل الرياضي مرحل الجهد المنخفض عبارة عن مرحل به جهات اتصال تعمل عندما ينخفض الجهد عن الجهد المحدد والذي يستخدم للحماية من انخفاض الجهد لاكتشاف ماس كهربائي وغيرها. أجريت هذه الدراسة لجميع أنواع العيوب التي تتعلق فقط بخط واحد من الخطوط المتوازية. بالنسبة لظروف التشغيل الإجمالية، تم إنشاء بيانات العينة للنظام عن طريق تغيير أنواع الأخطاء المختلفة وموقع الخطأ. يقترح نظام التصميم هذا استخدام الطريقة القائمة على لتصنيف الأخطاء بشكل سريع وموثوق وموقع لنوع مختلف من الأخطاء.

الكلمات المفتاحية: مرحل الجهد، مرحل حماية خط النقل، أنواع أعطال الجهد المنخفض وموقع الخطأ.

Introduction:

The power system is of essential importance in electrical power systems. The parameters that define the quality of a power system are voltage and frequency stability. Moreover, an upper limit on the current flowing through a power system is also vital to maintain. Operating conditions of a power system and connected loads are not necessarily always predictable, which causes power system to deviate from its standard operating values. One of many factors greatly affecting the voltage, frequency and current flow of a power system is the development of faults. A defect in a transmission line of the power system can cause current to stop flowing through that system is known as fault [1]. Its occurrence can be due to separate conductors, carrying different potential differences, coming into contact with one another. Usually, in the cases of faults, an unintended flow of current is established between at least two phases or at least one phase and the ground. As such, a fault that affects every phase similarly is termed as a "symmetrical fault". In the case, where some phases still remain unaffected, the fault termed as an "asymmetrical fault", proves difficult in its analysis [2, 3].

In a circuit transmission line, the fault can damage or disrupt the power system in several ways such as fault give rise to abnormal operating condition, become an unstable system and can cause the equipment to operate improperly. Within an interconnected power network system, if any type of short-circuit fault occurs, both current and voltage deviate from its normal values. So both, the current and voltage can be used to identify the fault and to operate the circuit breaker. Normally transmission lines have some voltage drop so even in normal conditions voltage supplied are slightly less than the normal value. Under voltage relay is used for protection to detect the fault location through the distance with the accurate fault type. This design system proposes the use of Matlab/ Simulink based method for fast and reliable fault classification and location for various types of fault.

Objective:

The aim of this paper is to design enhancement and development under voltage relay in power system protection using MATLAB/Simulink. The main objectives are:

1. To simulate a three-phase load supplied using a power-source of 400V in the form of a three-phase voltage.
2. To design an under-voltage relay by using MATLAB/Simulink.
3. To analyse the effect of various categories of faults such as phase-to-phase, line-to-ground, double-line-to-ground, and three-phase-to-ground faults, at their specific location based on the load voltage profile.

Project Scope:

The scope of this paper is to design enhancement and development under voltage relay in power system protection which is use the method of logic gates decision as the under-voltage relay to work and in case of the under voltage, it will trigger after the forced fault applies at the system. This method was used to protect the three-phase power system when the relay protection trips the circuit breaker connecting with load and voltage source in caseload voltage is dropped below a preset limit due to any fault. The MATLAB/ Simulink software is used to simulate the power system model for the output and input mapping methods. This simulation is covered with several of the fault-types which are line-to-ground (LG), line-to-line (LL) and three-line (LLL) faults, double-line-to-ground (LLG) and three-line-to-ground (LLLG) faults that functions at their specific location.

Literature Review:

One integral component of power systems is the transmission line as it forms an important link to the generating station. The probability of encountering faults is greater in a transmission line, so it's essential to promptly and accurately classify them. This paper will explain about types of faults, factor affecting faults in the transmission line, a function of the relay and what is under voltage relay with it uses [4, 5]. Many approaches use a mathematical tool like MATLAB, Simulink, PSIM and many more to design the under-voltage relay. Furthermore, it also summarizes several past of works based on other methods which used to classify fault type and designing the under-voltage relay which related to this project.

A. Types of Faults

By definition, a fault in electrical circuits is the divergence of current or voltage readings from those expected from the circuit. There are two primary types of faults that may be encountered in electrical power-systems: Symmetrical and asymmetrical faults These can be further divided into five different categories namely, single-line-to-ground (SLG), line- to-line (LL), double-line-to-ground (LLG), three-phase (LLL), and three-phases-to-ground (LLLG) faults. From these the LLL and LLG faults are symmetrical faults [6, 9]. Below will explain the type of fault that will be focused on this paper.

B. Single-Line-to-Ground Fault (SLG)

The single-line-to-ground fault is caused by the contact of a single conductor with the ground or neutral phase. This type of fault accounts for approximately 70% of 80% fault occurrences in electrical power-systems. The **Figure 1** provided below illustrates the scenario where a line from the three-phase system has broken insulation and is met with the ground causing a single-line-to-ground fault.

C. line-to-line fault (LL)

A line-to-line fault is encountered in the case two lines of the three-phase system come into contact and cause a short circuit. The primary reason observed for the occurrence of this type of fault is strong wind blows, as they cause displacement in the conductors allowing them to come into contact with one another. The **Figure 2** below illustrates the scenario where two phases are brought into contact causing a “flashover” to occur between them. [7, 10] The fault is considered to lie within the two phases “a” and “b” in order to analyze the

fault as a symmetrical fault keeping phase “a” as the reference, as such it is considered to be “upfaulted”. This category of faults accounts for on average 15% to 20% of fault occurrences.

D. Double-line-to-line fault (LLL)

The double-line-to-ground faults occur in the condition that two phases in addition to having contact with one another also touch the ground, as illustrated by **Figure 3**. The occurrence of these faults is approximately 15% to 20%. In the case that only the two phases meet one another due to the influence of wind is termed as a line-to-line fault. [7, 11]

E. Three-phase fault

Three-phase faults are commonly referred to as symmetrical (balanced) faults as every conductor in this system is concurrently short circuited with each other as they are connected directly, a configuration termed as a “bolted” connection. This type of fault is the same irrespective of its connection to the neutral (ground) phase [8, 12]. The **Figure 4** below illustrates this category of fault i.e., all three phases are in contact with each other.

F. Three-phase-to-ground fault

The **Figure 5** below illustrates the condition of three-phase-to-ground faults where all three phases in the system i.e., “a”, “b” and “c”, are in addition to one another in contact with the neutral phase or the ground. [8, 13]

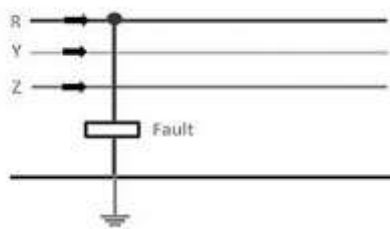

Figure 1: Single line to ground fault

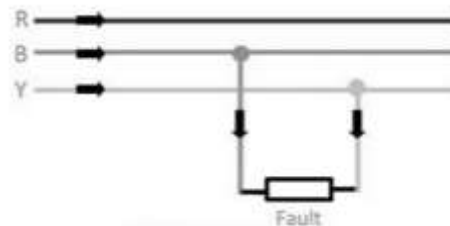

Figure 2: Line to line fault (LL)

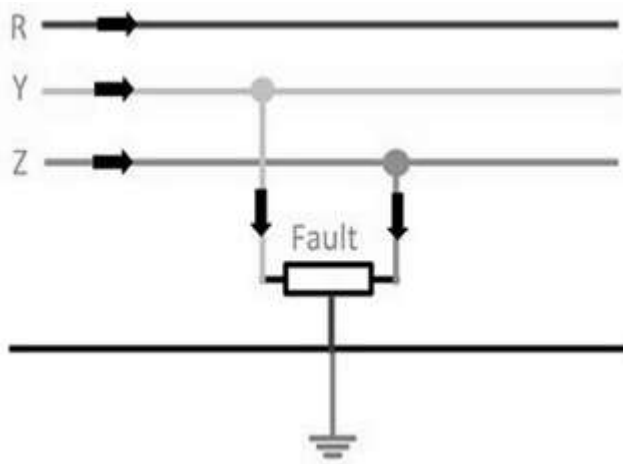

Figure 3: Double line to ground fault

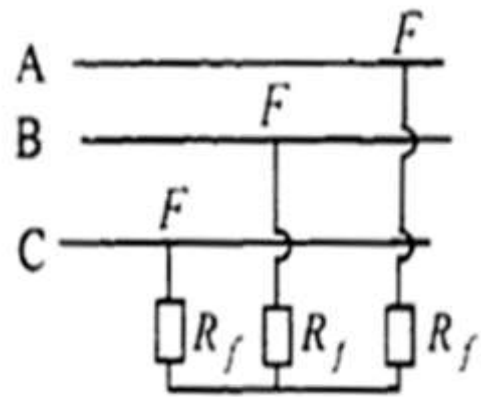

Figure 4: Three phase fault

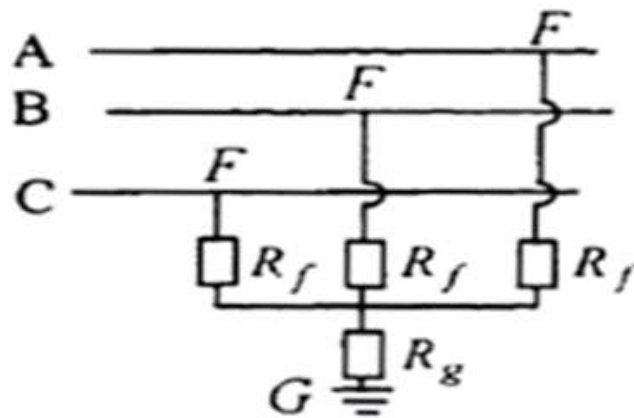

Figure 5: Three phase to ground fault

Subject and Methods:

A. Introduction

The illustrated and discussed the method of a three-phase load fed by a three-phase voltage power source simulation. Moreover, design back up protection by using an under-voltage relay as seen in **Figure 6**. Furthermore, analyze the effect of various types of faults at their specific location based on the load voltage profile. The project was carried out by using the MATLAB/Simulink to simulate the circuit.

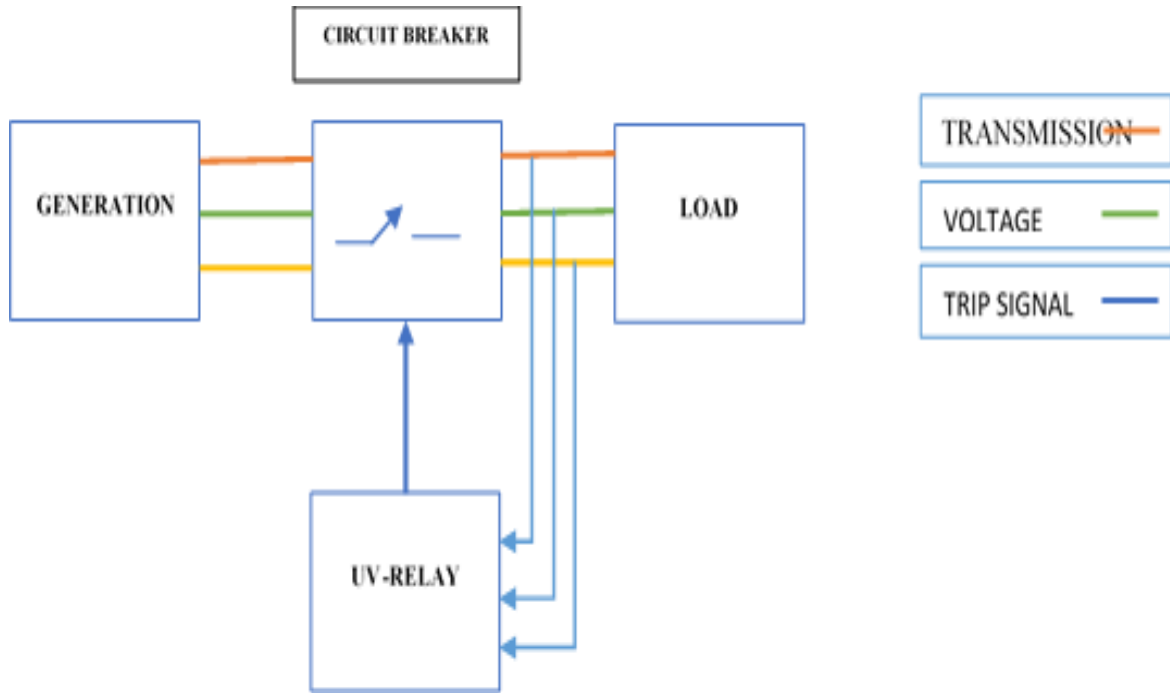

Figure 6: Block diagram of a protection system

B. Implementation in MATLAB/Simulink

From the basic introduction discussed above. Here the explanation of how designed the circuit by using Simulink of MATLAB. Simulink is a powerful tool for simulating the power system protection relay. **Figure 7** provides a general view of different protection system phases that is conducted in a sequential manner to make sure that protection system achieves its purposes.

The first part for design from began to end model the power system protection from generation to load and relay and circuit breaker. The final circuit of the designed protection system.

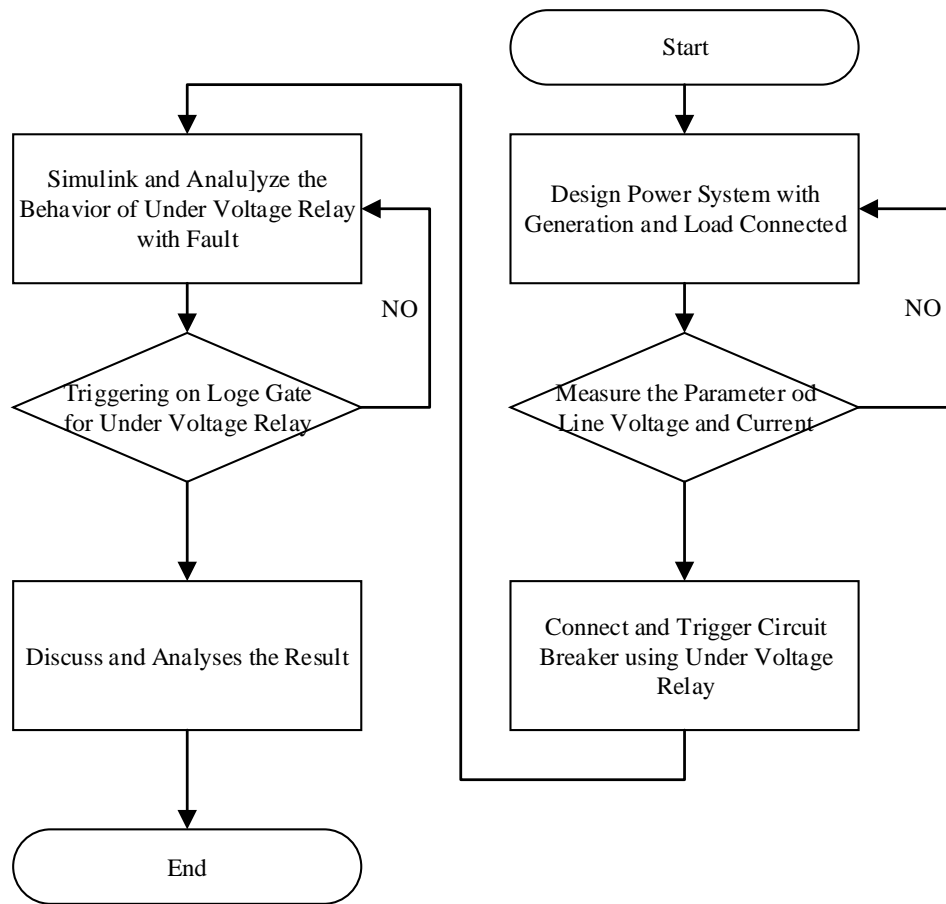

Figure 7: General flowchart of protection system design

C. Mechanism of under voltage Relay

The under-voltage relay is designed using logic gates. The flowchart of this algorithm is described below in **Figure 8**. The basic algorithm behind its working is explained below:

- a) Measure RMS value of transmission line.
- b) Compare this RMS value with the minimum set value of voltage.
- c) If RMS value is less than the set value for 3ms then trigger the breaker to open state and jump to step 5.
- d) If not, then keep the breaker in close state and go back to step 1 for some fault scenario.
- e) Then wait for a reset signal to reset the relay back to its original state.
- f) Go back to step 1 to repeat this process for some fault case.

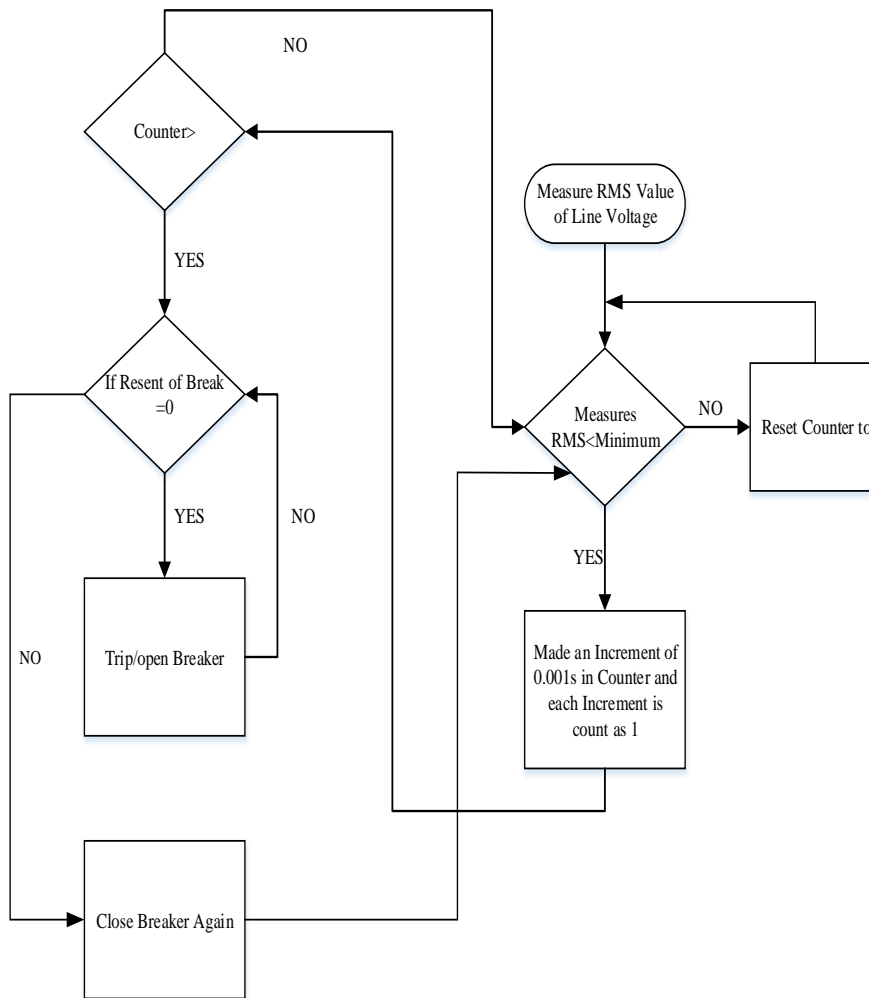

Figure 8: Mechanism of under voltage relay

D. Implementation of Under Voltage Relay in MATLAB/Simulink

The algorithm explained above is implemented in MATLAB as discussed below:

- Measure the voltage of transmission line of each phase and convert it into RMS value.
- Then, RMS voltage is compared with the minimum voltage level set for tripping, which is 90V. The output is inverted.
- As, the designing of this relay from a practical perspective, making sure that fault occurred is persistent rather than a glitch in a system is confirmed by introducing the delay in tripping time. So, a delay of 3ms is introduced using a delay block.

- d) The output delay is fed into S-R flip-flop which will decide whether the system should continue to work or stop. At this stage, the output of delay unit and reset button decided the triggering status of the relay. Blocks up to this stage.

E. Truth table of top three flip-flops

The truth table of top three flip-flops is explained below, for both the cases when the voltage of the system is above and below the limit of triggering. This can be divided into four regions of operations, as shown in **Figure 9**.

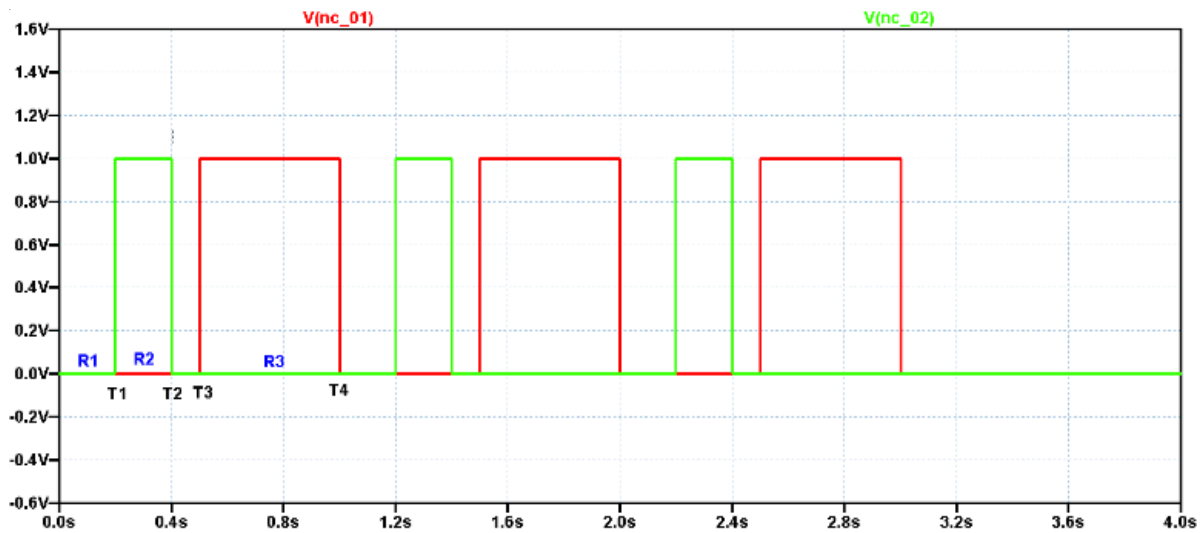

Figure 9: Regions of operations

Then, the R1 (From T=0 to 0.2 sec) and R3 (From T=0.2 to 0.4) are a normal operating region, whereas R2 is fault region. More precisely R3 (From T=0.5 to 1) is said to be as RESET region because reset again to close state:

- a) R1: When the voltage of the system is above the triggering limit:

As the voltage of the system is more than the minimum voltage required for triggering. By using this data, the following truth table can be constructed. The truth table for top three Flip Flops and the truth table for the lowest F/F reset.

- b) R2: When the voltage of the system is below the triggering limit (a fault has occurred):

As the voltage of the system is less than the minimum voltage required for triggering. By using this data, the following truth table can be constructed as below table. The truth table for top three Flip Flops is given in Table 3.4 and the truth table for the lowest F/F reset.

- c) R3: When the system is to reset again:

As the voltage of the system is more than the minimum voltage required for triggering but now the reset signal is on. So, using this data the following truth table can be constructed. First, the truth table for fourth Flip Flops will change and the truth table for the upper three Flip Flops.

F. Simulation Results

First will see that designed relay is working on five of the faults in the transmission line. So, run the simulation with all the data discussed above and the output that confirms the satisfactory working of the relay is shown below.

G. Three phase to ground fault

In this **Figure 11** the sinusoidal waves are the voltages of the transmission line for phase A, B, and C. It can be seen that as the red square wave shape of fault timer becomes active then after a delay of 3ms the under-voltage relay opens in **Figure 10**. So, the designed model is fine. Then, to confirm that does this system triggers according to the minimum voltage set of 246.5V (RMS) for three phases. This is confirmed by the graph of RMS values of voltages as shown **Figure 13**. The comparison of the time values plots the graph showing time comparison among the fault, relay tripping and reset of relay the y, as shown **Figure 12**.

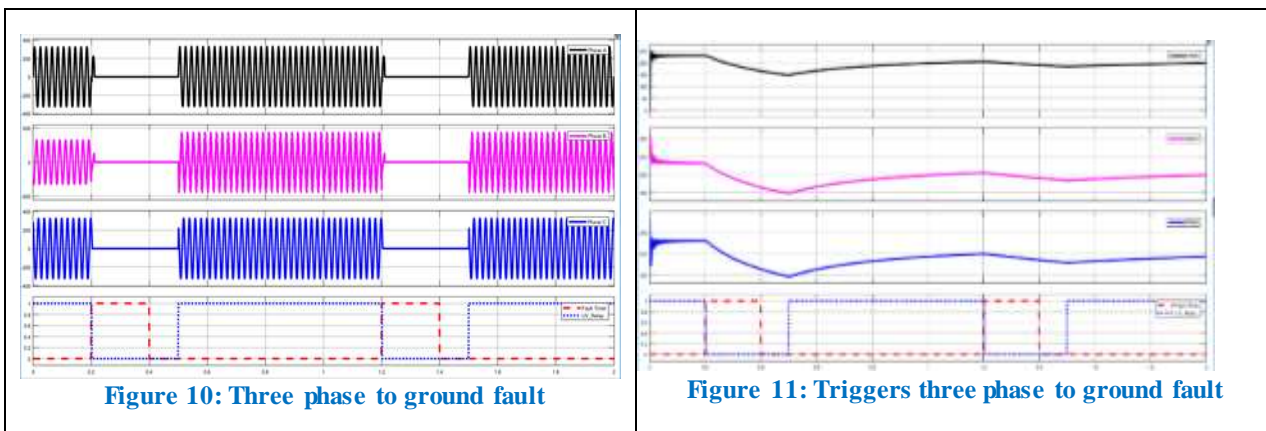

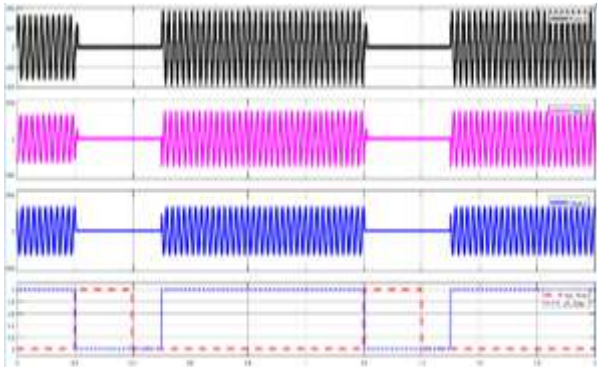

Figure 12: Phase-to-phase faults in phase B and phase C

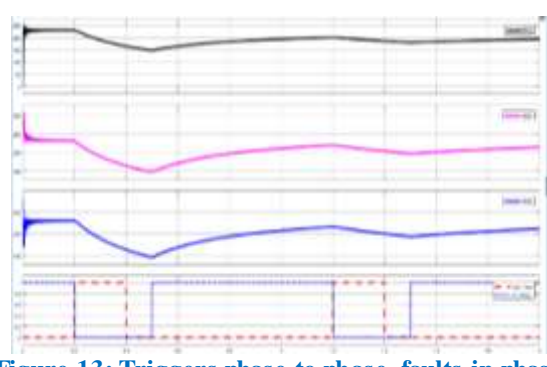

Figure 13: Triggers phase-to-phase faults in phase B and phase C

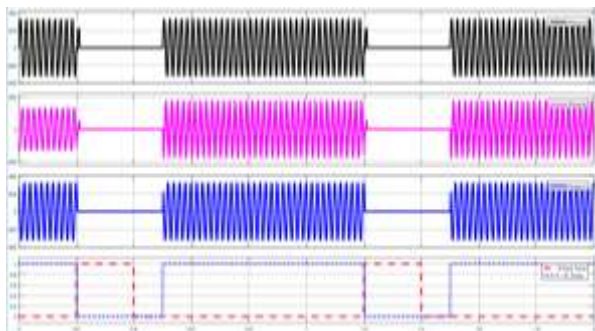

Figure 14: Double Phase to ground faults in phase A and B to ground

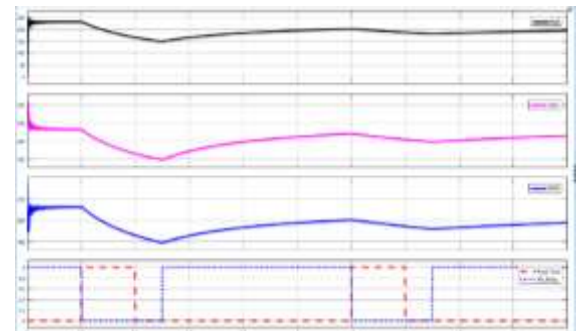

Figure 15: Triggers double phase to ground faults in phase A and B to ground 10

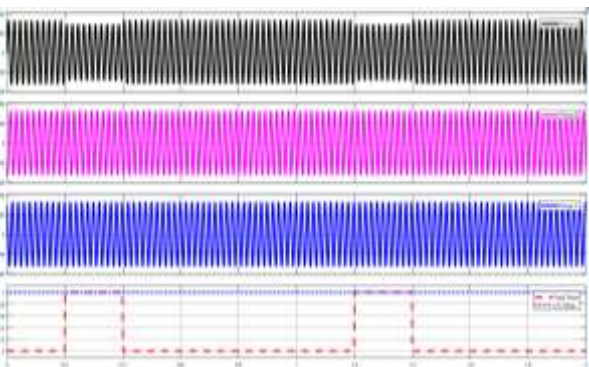

Figure 16: Phase to ground faults in phase A to ground

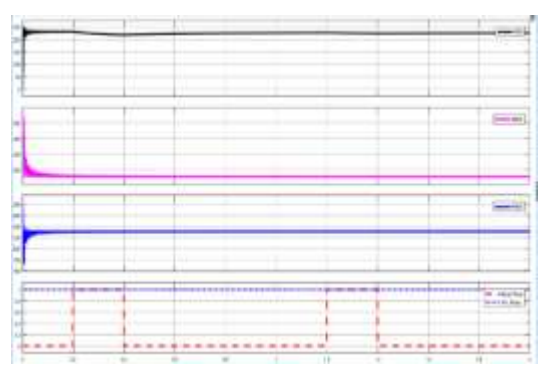
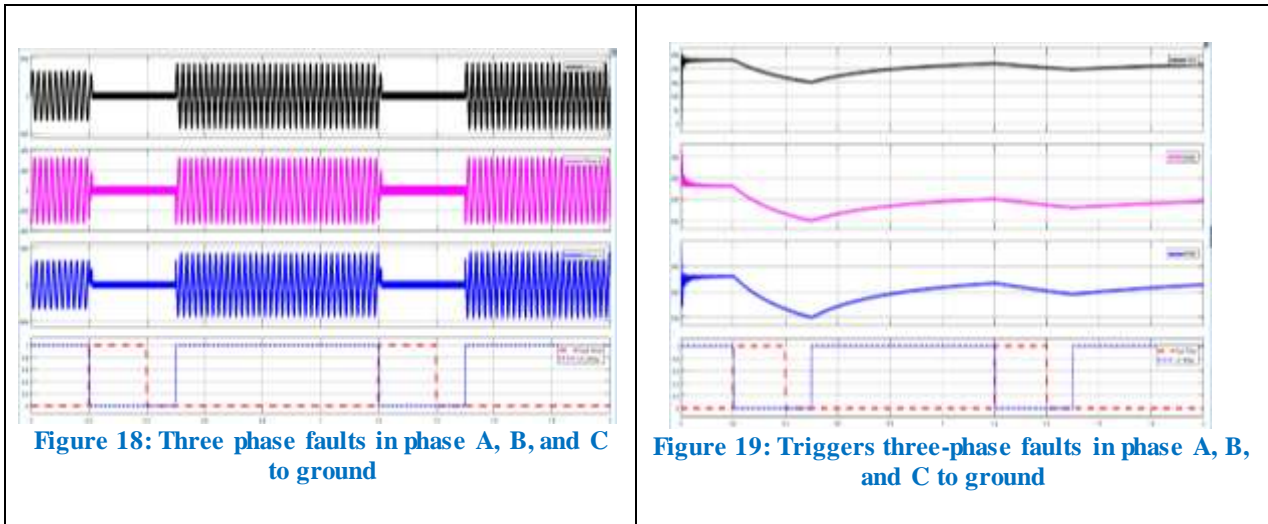

Figure 17: Triggers phase to ground faults in phase A to ground



H. Phase-to-phase fault

Phase-to-Phase faults occurs when two phases from the three-phase electrical system are brought into contact and cause a short-circuit. The position at which the phase-to-phase fault lies (Figure 15), exhibits a reduced voltage and a higher current in comparison to the third un-faulted phase (Figure 14).

I. Phase-to-ground fault

Single-phase to ground faults occur when a single phase from the three-phase electrical system comes into contact with the ground causing a short-circuit. Figure 16 illustrates the wave-form exhibited by a phase-to-ground fault on a 400V three-phase system, where it can be observed that the A-phase (faulted phase) shows a lower voltage. Additionally, Figure 17 represents different stages of the voltage wave-form in terms of amplitude height and timing i.e., the initial two cycles show the pre-fault voltage, the following four cycles show the voltage during fault, and the last cycle is of the post fault voltage.

J. Double phase to ground fault

The Double-phase-to-ground fault is the occurrence of a fault due to the short-circuit of two phases from the three-phase electrical system in addition to connection with the neutral phase or ground (Figure 19). The unintentional current path produced by such a fault will cause the voltage at the two faulted phases to be reduced and the voltage at the ground to be elevated to a value higher than the third un-faulted phase (Figure 19).

K. Three-phase fault

Figure 20 illustrates the voltage-waveforms for a three-phase fault in a 230V electrical system, with the three phases labelled as “A”, “B”, and “C”. The two initial cycle of the diagram show the pre-fault voltage, the following four cycles illustrate the voltage during the fault, and the last cycle shows the post fault voltage. The peak voltage, marked on the y-axis of the graph that denotes the voltage readings, is found to be 325V ($230V \times \sqrt{2}$) for this system. Likewise, the period of a single cycle, denoted by the x-axis in degrees, is calculated to be 16.7 ms (1 cycle = 360 degrees). Using satellite clocks the data that may help to analyze the fault is time stamped, along with corresponding root-mean-square value of the voltage. The voltage is restored while the current is disrupted in the case the fault is corrected, as such the Figure 21 shows the voltage variations due to a fault in a transmission-line. On the condition that the position of the fault is in close proximity to the terminals of the transformer, the volage on all three phases would be negligible throughout the period the fault remains active. Likewise, in the situation where the position of the fault is along the transmission line the voltage is disrupted by the opening of the breaker that is designed to set apart the fault carrying region.

Wherever three-phase electrical systems are utilized this type of fault should be expected and prepared for. However, in the process of transmission, these faults prove less possibility of occurrence owing to the adequate separation given to the three conductors. Conclusively, identification of faults in power systems can be challenging. Usually, phase to ground faults are anticipated as restricted types of faults

Conclusions:

In the conclusion the electrical power system is a very important part of the power system, there are different types of faults have different effects on power system parameters. Therefore, a protection system is greatly required, which monitors the different portions of a power system for different parameters. To analyze the effect of various types of faults (phase to ground fault, phase to phase fault and three phase fault, double phase to ground fault and three phase to a ground fault) at their specific location based on the load voltage profile. The power system of under voltage to study of design enhancement and development under voltage relay in power system protection using MATLAB/Simulink software. Simulink is a visual simulation tool of MATLAB, incorporates power system or algorithm models and export simulation results to MATLAB for further analysis. To simulate a three-phase load fed by a three-phase voltage power source of 400V.

In a circuit transmission line, the fault can damage or disrupt the power system in several ways such as fault give rise to abnormal operating condition, become an unstable system and can cause the equipment to operate improperly. Under voltage, the relay is used for protection to detect the fault location through the distance with the accurate fault type. This design system proposes the use of MATLAB/ Simulink based method for fast and reliable fault classification and location for various types of faults.

Identification of faults in power systems can be a challenging task. Usually, phase to ground faults are anticipated as restricted types of faults. The primary focus in categorizing faults in terms of phases and ground is for calculation of set-points for protective-relays, as well as research concerning the transient stability and co-ordination of these devices. In general, phase related faults are coupled with phase-relays and ground related faults are coupled with ground-relays. Research regarding the transient stability of these relays is directed towards reducing the time taken to resolve faults or at the very least reduce them to single-line to ground faults, to allow generators both in close proximity and those at a greater distance to keep synchronization with one another.

Reference

- [1]. Z. Qingchao, Z. Yao, S. Wennand, and F. Dazhong, “Transmission line fault location for single-phase-to-earth fault on nondirect-ground neutral system,” IEEE Trans. Power Delivery, vol. 13, no. 4, pp. 1086–1092, Oct. 2008.
- [2]. Grainger, John J, *Power System Analysis*. Tata McGraw-Hill. p. 380. ISBN 978-0-07-058515-7, 2015.
- [3]. Campbell Drive, “What is undervoltage? How can I protect my equipment?”, Available [Online]: <https://www.macromatic.com/blog/relays/what-is-undervoltage>.
- [4]. K. G. Narendra, V. K. Sood, K. Khorasani, and R. Patel, “Application of a radial basis function (RBF) neural network for fault diagnosis in HVDC systems,” IEEE Trans. on Power Systems, vol. 13, no. 1, pp.177–183, 2004.
- [5]. A. A. Girgis, D. G. Hart, and W. L. Peterson, “A new fault location for two-and-three-terminal lines,” IEEE Trans. Power Delivery, vol. 7, no.1, pp. 98–105, Jan. 2008.
- [6]. Fault location on distribution systems: An update on EPRI and DOE research”, IEEE Distribution Subcommittee presentation, Orlando, FL, Jan. 10, 2007.
- [7]. Circuit globe, “Types of faults in power system”, Available [Online]: <http://www.circuitglobe.com>.

- [8]. Oyetunji Samson A.,” Real-Time Evaluation of System Dynamics to Improve Network Performance in Akure Electric Power Distribution System in Nigeria”,2012.
- [9]. “Orthogonal least squares learning algorithm for training multi output radial basis function networks,” in IEE Proceedings-F., vol. 139, no. 6, pp. 378–384, Dec. 2012.
- [10]. Cheng-Ting Hsu, “Under-voltage relay settings for the tie-lines tripping in an upgrading cogeneration plant” in IEEE Region 10 Conference TENCON, Vol 3, pp.264-267, 2004.
- [11]. Omer Ozgur Gencer, Semra Ozturk, Korhan Karaarslan, “Performance of an Over/Under Voltage Relay at Non-sinusoidal Conditions” IEEE Melecon,2006.
- [12]. C. S. Chen, Y. D and Lee, C. T. Hsu, “Design of under voltage relay settings for an industrial plant with cogeneration units” ,2007.
- [13]. Sharma V. Kolluri and Jayanth R. Ramamurthy, “Relay-based Undervoltage Load Shedding Scheme for Entergy’s Western Region”,2015.