

Modeling and Simulation of Wind Turbine Generator Using Matlab-Simulink

Roshen T. Ahmad

roshen62@yahoo.com

University of Technology

Mahdi A. Abdul-Hussain

mahdiobaydi@yahoo.com

University of Technology

Abstract: *Wind energy utilization for power generation purpose is becoming high interest in electrical power production as a result of easy access to the wind and not be affected by any environment that is clean and sustainable source of energy.*

In this research a mathematical model and its parameters has been studied that affect the electrical output power generated by the wind turbine. These parameters are wind speed which is affected by temperature that cause air density change and that lead to vary wind speed, and power coefficient as a function of pitch angle and blade tip speed.

The modeling and simulation technique will play great role in the design and analysis of these wind turbines.

In the past years, the demand of Matlab-Simulink is one of the most common software, which is important for modeling, and simulation of dynamic systems. It provides a graphical interface, easy to access, design, build and verify mathematical models.

These programs can easily make new designs and strategies control as well as tests. The wind turbine generators are the best example of these dynamic systems.

Keywords: *wind turbine, Matlab simulink, Renewable energy.*

Abbreviations:

P = Mechanical power in the moving air (Watt).

ρ = Air density (kg/m^3).

A = Area swept by the rotor blades (m^2)

V = Velocity of the air (m/s)

C_p = Power coefficient.

o/p = Output

Ω = Mechanical speed at the rotor shaft of the wind turbine (rad/s)

R = Radios of the blade (m).

V = Velocity of the air (m/s).

TSR = Tip Speed Ratio.

β = Blade pitch angle.

1. Introduction

Wind turbine is designed to convert the wind energy into electric energy. The wind turbine system consists of three main parts: the rotor, which includes the blades to convert wind energy to low speed rotational energy. The second part is the generator that includes the electrical generator, which include all control circuits with gearbox that convert the rotational low speed into electric power and finally the structure that hold all the previous components and that is the tower and nacelle.

Wind turbine is classified into two main groups depending on their axis in which the turbine rotate. it can be classified into horizontal axis and vertical axis. Because the horizontal axis has the ability to collect the maximum amount of wind energy for the time of the day and can adjust their blades pitch angel to avoid high windstorms, they are considered more familiar and more common than vertical axis [1].

Understanding of wind properties is very important for wind energy exploitation. Speed of wind is highly variable both geometrically from place to place and temporally, seasonal and in hourly means.

In addition to seasonal changes in the wind speed, there are some variations on the shorter time scale. These variations are called synoptic variations and they have a peak at around 4 days.

Beside the seasonal and synoptic components in the wind speed, there is a turbulence component. This turbulence refers to fluctuations in wind speed on relatively fast time-scale, typically less than 10 min.

In studying the wind energy affection into a wind turbine it is very important to know the mean wind speed determined by the seasonal, synoptic and diurnal effects, which varies on a time, with turbulence fluctuations superimposed [2, 3].

2. The determination of wind turbine properties and performance curves:

Power, torque and thrust are three indicators that varying with the wind speed which characterize the performances of a wind turbine. The amount of energy captured by the rotor determine its power, the size of the gearbox determine its torque, while the rotor thrust has a great influence on the structural design of the tower.

A wind turbine captures energy from moving air and converts it into electricity. Air density, power coefficient, air density and turbine swept area are parameters that affect the captured energy as shown in the following equation:

$$P = 0.5 \times \rho \times C_p \times V^3 \times A \quad \dots (1)$$

Where:

P = Mechanical power in the moving air (Watt).

ρ = Air density (kg/m^3).

A = Area swept by the rotor blades (m^2)

V = Velocity of the air (m/s)

C_p = Power coefficient.

Maximum power that can be achieved from an ideal turbine rotor with infinite blades from wind under ideal conditions is 59.26% (0.5926 times) of the power available in the wind as proved by scientist Betz and this limit is known as the Betz limit. Wind turbines are designed to have two or three blades due to a structural and economic considerations, and hence, the amount of power they can get is closer to about 50% (0.5 times) of the available power.

Tip speed ratio (TSR) of a wind turbine is defined as:

$$\lambda = (\Omega \times R) / V \quad \dots (2)$$

Where:

Ω = Mechanical speed at the rotor shaft of the wind turbine (rad/s)

R = Radius of the blade (m).

V = Velocity of the air (m/s).

The TSR, and blade pitch angle β , are used to calculate the rotor power coefficient, denoted by C_p . The rotor power coefficient can be calculated as:

$$C_p = (\text{Extracted power}) / (\text{Power in wind})$$
$$C_p = P_{\text{rotor}} / P_{\text{wind}} \quad \dots (3)$$

Equation 1 can be written as:

$$\text{Power} = 0.5 \times \rho \times C_p(\lambda, \beta) \times V^3 \times A$$

Variable-speed wind turbines are equipped with a pitch-change mechanism (Pitch angle control) to adjust the blade pitch angle and obtain a better power coefficient profile cause it control its rotation speed [3, 4].

3. Wind turbine modeling:

Wind turbine consists of the following subsystems as shown in figure (1):

- Rotor blades and hub.
- Nacelle contains shafts, gearbox, couplings, brake, and generator.
- Tower that hold the Nacelle.
- Electrical system such as switchgear, transformers, cables, and power converters.

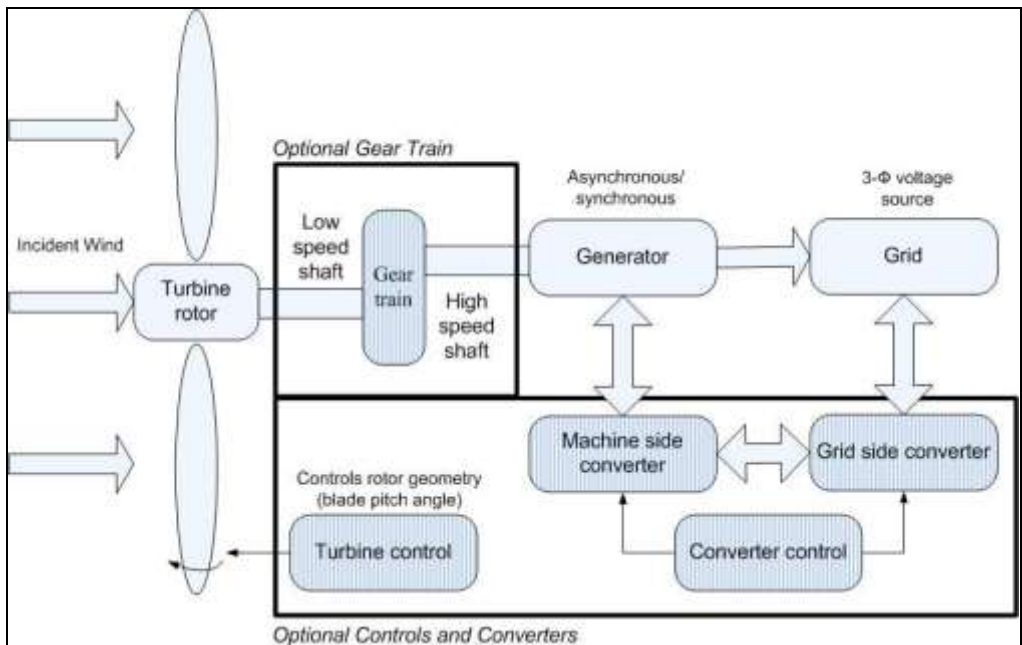

Figure (1): Modern wind turbine diagram.

4. Matlab Simulation:

4.1 Power equation simulation:

A Matlab-Simulink model (Fig. 2) has been build to show how these factors (equation 1 and 2) affect the generated power from wind turbine while figures (3, 4, and 5) show the output results. The Simulink model can be used for wide ranges of wind turbines.

The specification of the suggested wind turbine is listed table (1) and can be changes to any values by changing the setting values of the blocks [5, 6]:

Table (1) Specification of the suggested wind turbine

Rotor Diameter	52 m
Swept area	2.125 m ²

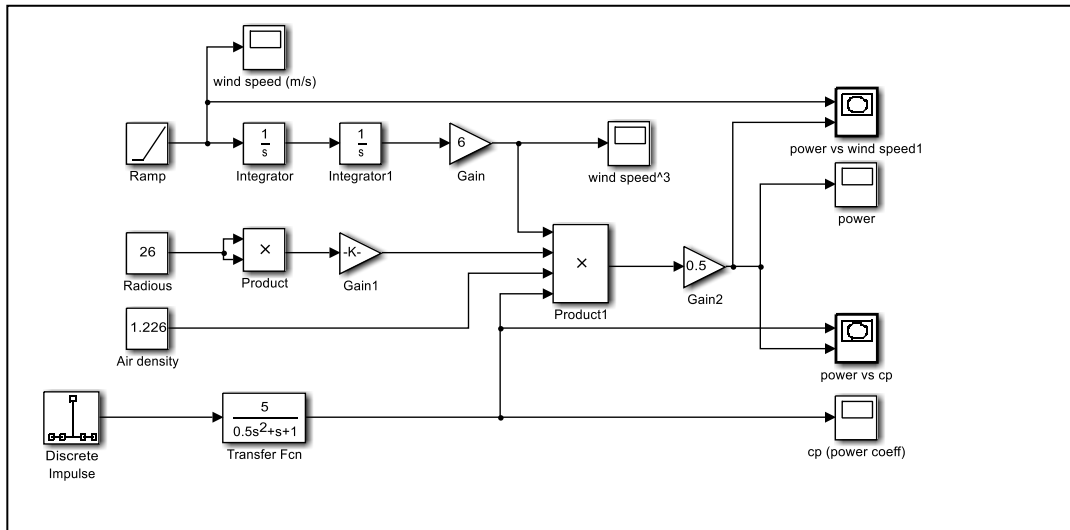

Figure (2): Matlab-simulink for equation 1 and 2.

4.1.1 Results and discussion for the power equation simulation:

From the results one can see the variation of wind speed with time as shown in figure (3) and in actual the wind speed is not constant so the curve is nonlinear, wind speed in this simulation block diagram can be generated by integration two times the Ramp function as shown in the first top part of figure (2) and after that multiply it by 6 to get the wind speed 3 , also the power and power coefficient. Swept area must be taken into consideration in terms of the local area conditions to capture power as maximum as possible in order to get best wind turbine.

As can be seen from figures (4 and 5) the output power of a wind turbine is directly related to the wind speed and tip speed ratio as explained in equation 2 which in turns is a function of blade pitch angle, the power increase with wind speed till some value and after that it will decrease because of the control system which placed in the nacelle of the wind turbine in order for the safety of the turbine.

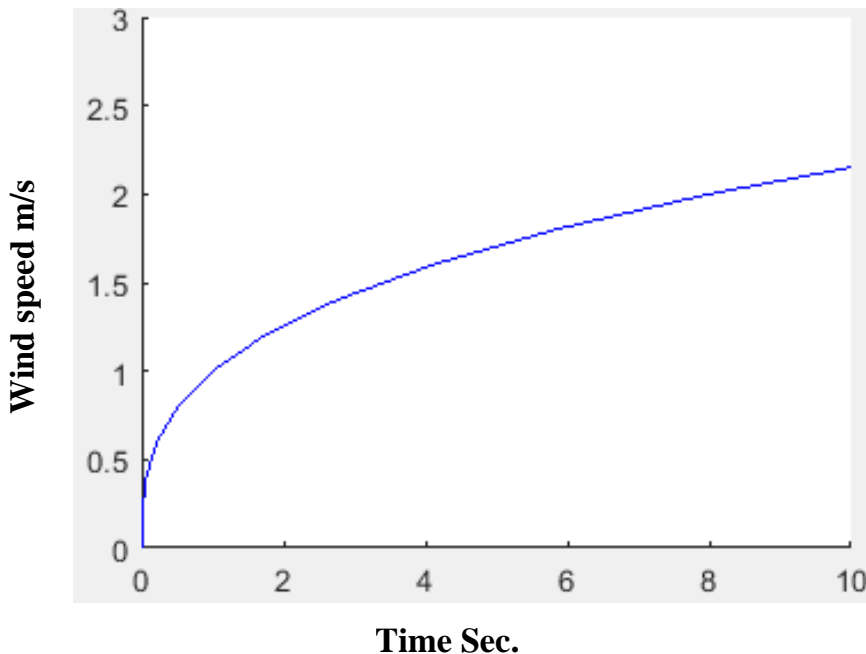

Figure (3): Wind speed m/s simulation

Blade swept area has great effect on power. The diameter of the rotor has directly proportional with the power can be extracted from the wind. Air density has a great effect on wind turbine performance. The power available in the wind is directly proportional with air density too as air density increases, the power also increases and vice versa. In addition, air density is a function of air pressure and temperature.

It proportional directly with air pressure and proportional inversely with temperature. In the same time temperature and pressure proportional inversely with increasing elevation [7, 8].

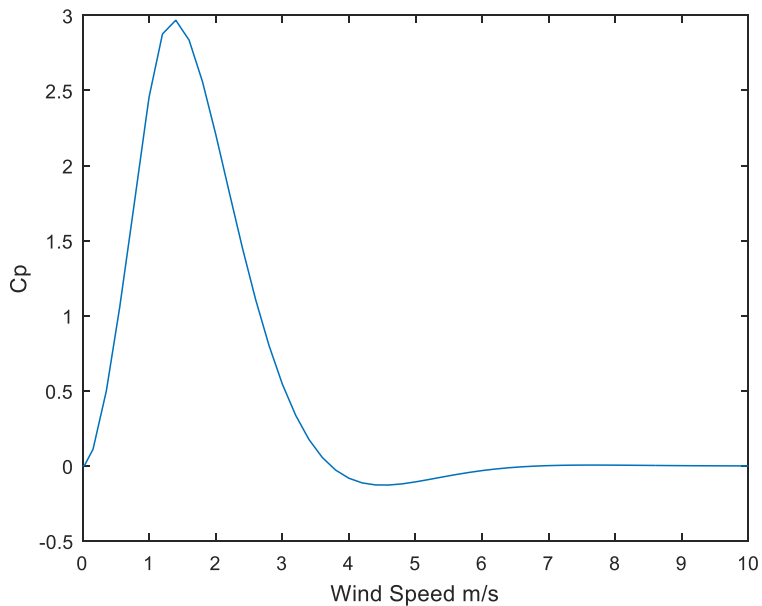

Figure (4): The relation between wind speed and Cp.

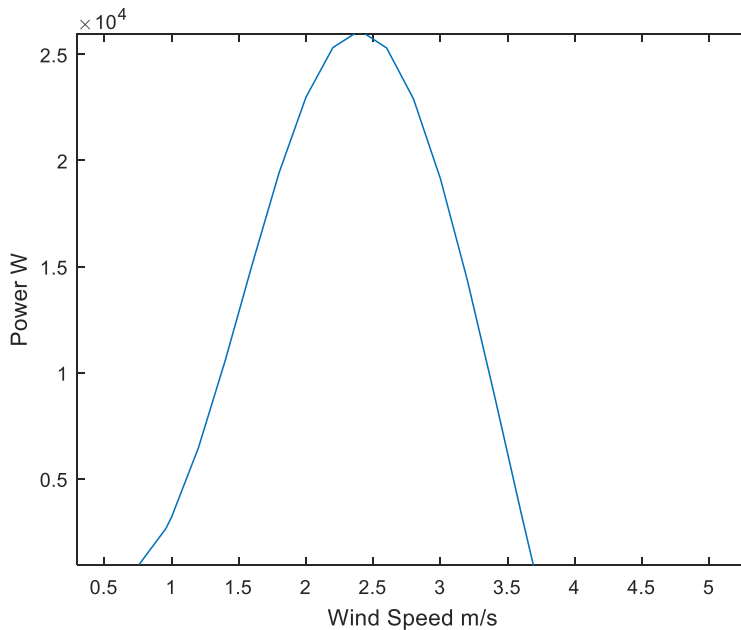

Figure (5): The relation between wind speed and power.

4.2 Wind turbine plant modeling:

A wind power plant has been designed by using Matlab-Simulink as shown in figure (6), which is equivalent to the above block diagram. The designed system consist of a 1.5 MW (can be changed to any value) wind turbine connected to a load 400 KVA and electric power source 25 KV through three phase transformer, the active and reactive power is measured for different wind speed and different pitch angle of the blade. Figures (8, 9, and 10) shows the relation between turbine speed (which it depend on wind speed) and the turbine output power for different wind speed and pitch angle of the blades. These values can be changed by changing the system blocks parameters very easily and this is the advantage of using Matlab-Simulink [9].

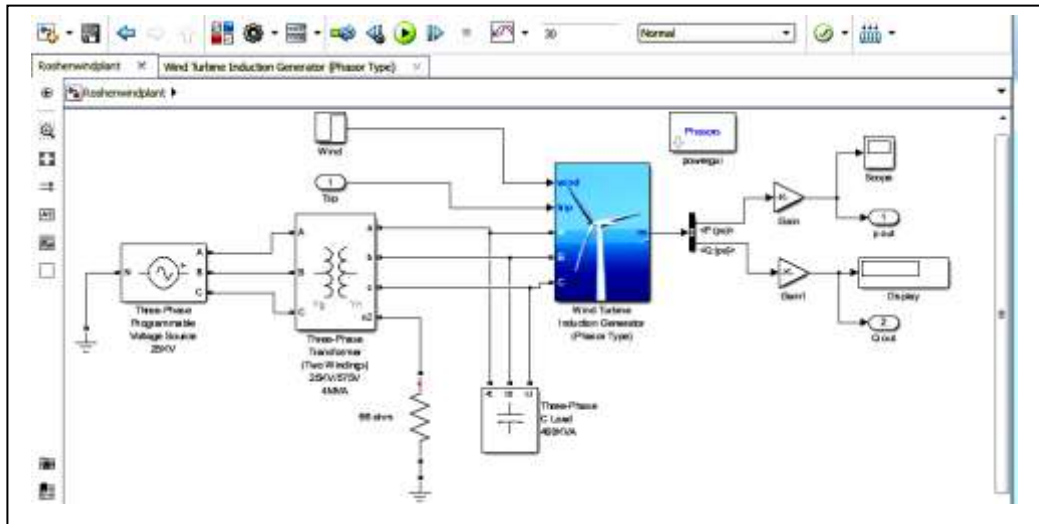

Figure (6): (1.5 MW) wind turbine power plant.

Pitch angle can be defined as the angle of attack of the wind with the blade. Changing pitch angle means that the angle of attack of the wind is changed, this can be done by changing the set of the wind turbine in Matlab-simulink in the wind turbine parameters block as shown in figure (7), for example when the pitch angle is zero and wind speed is 12 m/sec we get maximum power as shown in figure (8) but if we change the pitch angle to 5 and 10 respectively for the same wind speed the output power is decrease and this indicate the effect of pitch angle on the output power as shown in figure (9,10).

So the pitch angle value must be evaluated for optimum wind speed in order to get best output power such as it change automatically when the speed is high or low and this done buy using proper position control, the optimum pitch angle value is set as set point for the wind turbine. This position control system change the pitch angle according to wind speed, for example for high wind speed the pitch angle decrease and for low wind speed the pitch angle increase to get constant speed and after that to

obtain best output power and for the safety of the blades structure [8, 10].

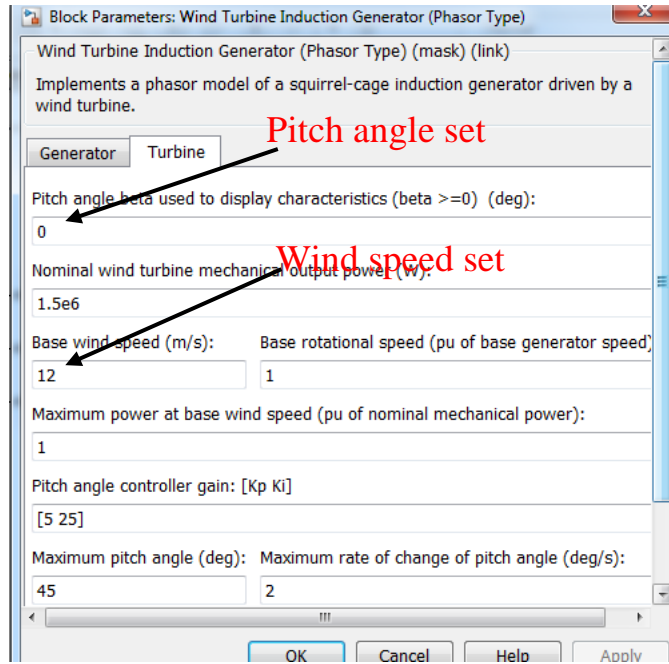

Figure (7): The wind turbine parameters setting block.

4.2.1 Results and discussion for the wind turbine plant:

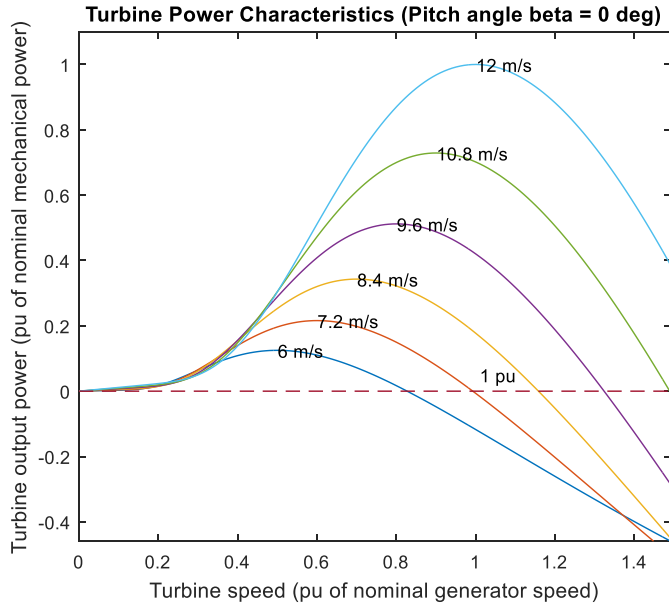

Figure (8): Turbine speed vs. o/p power for pitch angle equal zero.

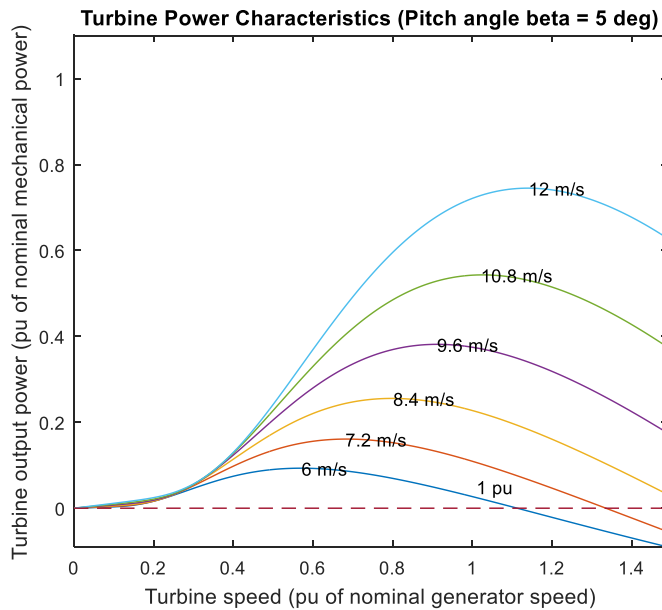

Figure (9): Turbine speed vs. output power for pitch angle equal 5.

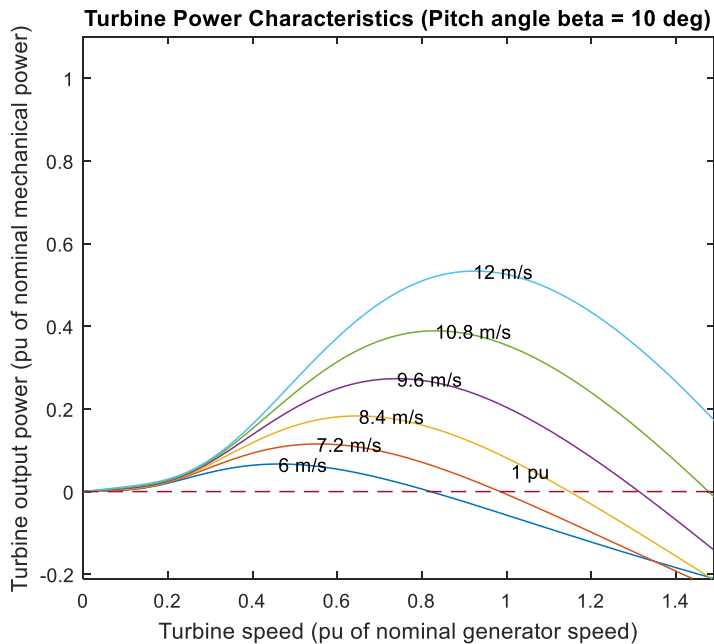

Figure (10): Turbine speed vs. o/p power for pitch angle equal 10.

Power in an electric circuit can be defined as the rate of flow of energy past a given point of the circuit. In alternating current (AC) circuits, energy storage elements such as inductors and capacitors may result in periodic reversals of the direction of energy flow. The portion of power that, average over a complete cycle of the AC waveform in net transfer of energy in one direction is known as Active power (sometimes also called real power).

In this research, one can see the effect of changing wind speed on the output power (Active power) when the pitch angle is constant. This can be done in the same wind turbine parameters block as shown in figure (7).

The output power of the wind turbine depend on wind speed, so the output power change when the wind speed is change as shown in figure (11). The maximum power for the wind turbine designed in this research is 1.5 MW as described previously when the wind speed is 12 m/sec and higher and that because of

the pitch angle position control while for less wind speed the output power is decrease, the position control is work to increase the output power by changing the pitch angle to a certain value so the fan rotate at higher speed and vise versa [10].

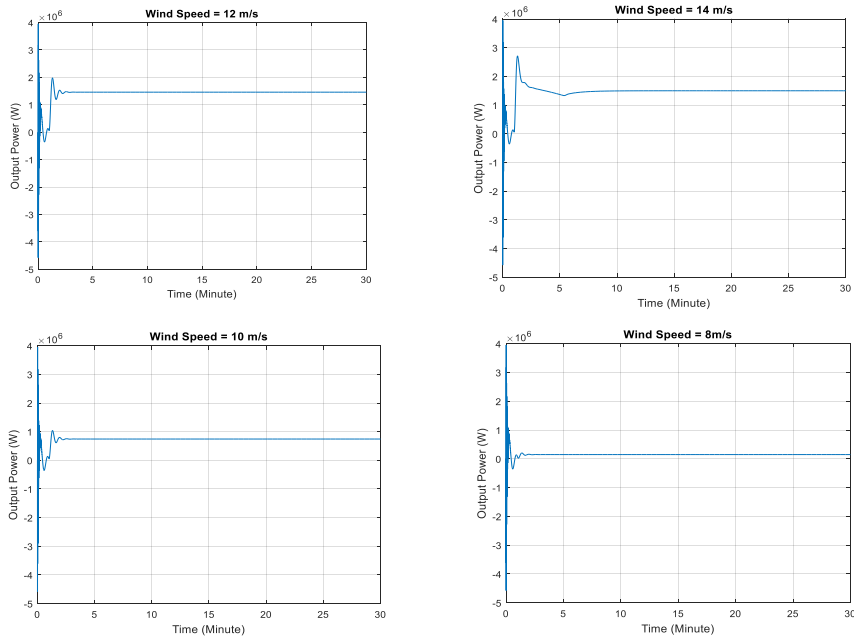

Figure (11): Wind turbine output power for different wind speed.

Figure (12) combine all the curves in figure (11) in one curve to notice the effect of wind speed variation on the output active power.

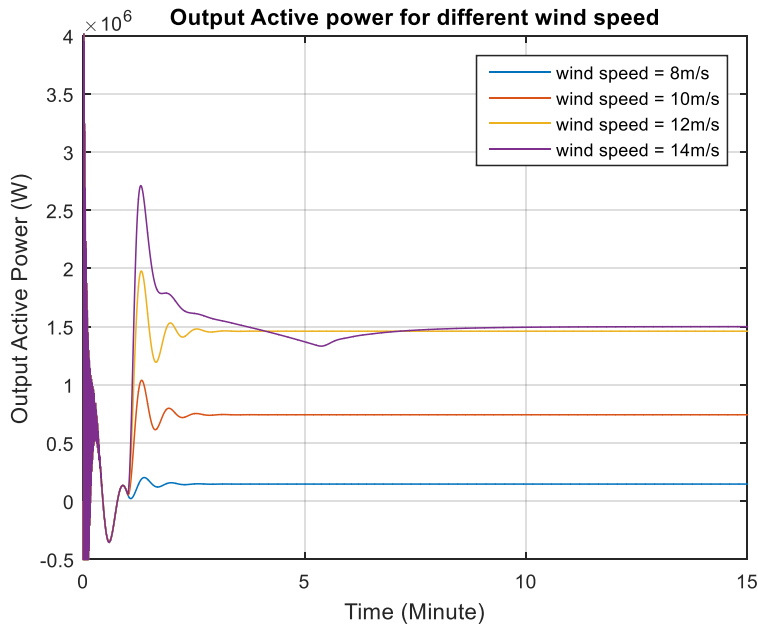

Figure (12): Wind turbine active power.

Also in this research, measuring the reactive power has been done in order to get complete information about wind turbines.

Reactive power can be define as the portion of power due to stored energy, which returns to the source in each cycle, figure (13) shows the wind turbine reactive power curves for different wind speed. Finally figure (14) shows an image of the Matlab-Simulink scope display which shows the output curve of the suggested wind turbine [10].

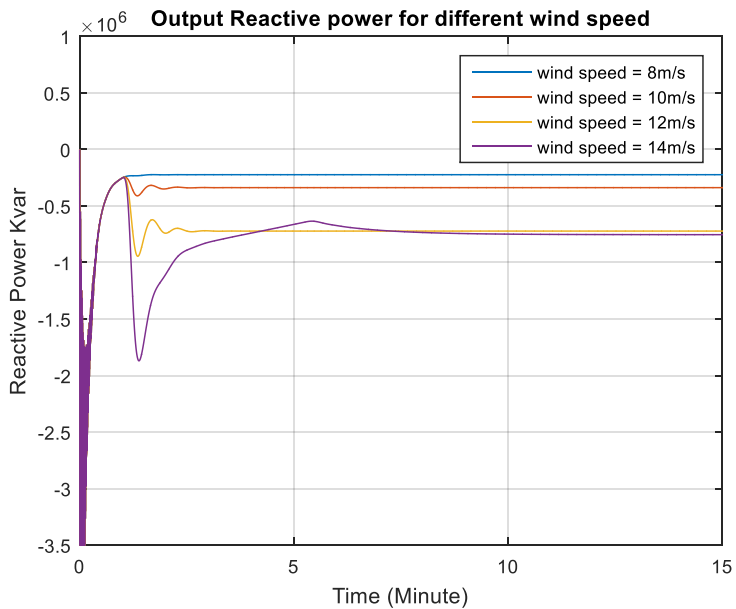

Figure 13 Wind turbine reactive power.

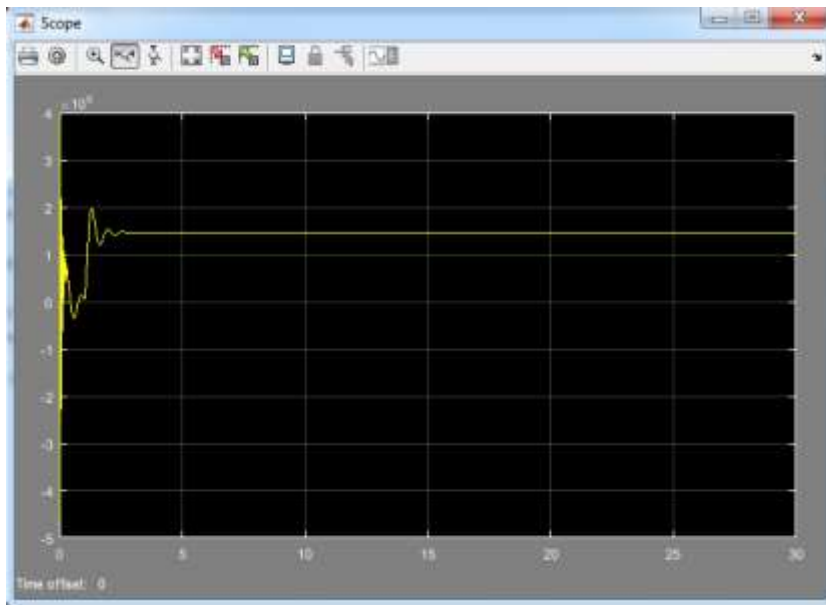

Figure (14): Scope display of the Matlab-Simulink.

5. Conclusion

Studies of wind energy for power generation purposes have a great interest in the electricity market. The good exploitation of wind energy may enhance the renewable power generation capabilities, increase its capacity factor, and participate in generating electricity at good costs.

Many parameters taken into consideration during manufacturing or installation of wind turbines, such as air density, wind speed, and power coefficient as a function of pitch angle and blade tip speed as shown in figures (3, 4, and 5).

In this research modeling and simulating of a wind turbine generator by using Matlab/Simulink have been done as shown in figure (6). A model built in this study is easy to be understood. The integration of the developed wind turbine model with the public electrical grid was presented in the work.

After building the model, it has been used in order to verify its usefulness; a study of its behavior when integrated in whole power system was needed. Many wind speed levels taken into consideration i.e. from low with 8 m/s as the mean value, medium with 10-12 m/s as the mean value and high with 14 m/s as the mean value. These allowed predicting and supervising the active and reactive power produced by the system as shown in figures (8, 9, 10, 11, 12, 13 and 14).

References:

- [1] M. Vyas, M. Singh, and S. Santoso,, "Handbook Of Wind Power System", Springer, 2011.
- [2] Thomas Ackerman, "Wind Power In Power Systems", Royal Institute of Technology Stockholm, Sweden, Edition: John Wiley and sons, Ltd, 2005.
- [3] T. Burton, D. Shape, N. Jenkins, E. Bossany, "Wind Energy Handbook", J. Wiley & Sons, Ltd. 2001.
- [4] Herbert, G. M. Iniyar, S., Sreevalsan, E, and Rajapandian,, "Review of Wind Energy Technologies", Renewable and Sustainable Energy Reviews, S.A. 2007.

- [5] T. Petru and T. Thirnger, "Modelling Of Wind Turbines For Power System Studies", IEEE Trans. Energy Convers. Vol. 17, No. 4, pp. 1132-1139, Nov. 2002.
- [6] C. M. Ong, "Dynamic Simulation Of Electric Machinery using Matlab/Simulink", Prentice-Hall PTR, 1998.
- [7] Fingersh, L., Hand, M., and Laxson, A. 2006. "Wind Turbine Design Cost And Scaling Model", Technical Report NREL/TP-500-40566: Cole Boulevard, Golden, Colorado, 2009.
- [8] "Simulink-Simulation and Model-Based Design/Mathworks", Mathworks.com/simulink, 2012.
- [9] L. Hansen, P. Madsen, F. Blaabjerg, H. Christensen, U. Lindhard, and K. Eskildsen, "Generators And Power Electronics Technology For Wind Turbines", in the 27th Annual Conference of the IEEE Industrial Electronics Society (IECON), vol. 3, pp. 2000 –2005, 2001.
- [10] M. G. Gracia, M. P. Comech, J. Salla and A. Llombart, "Modeling Wind Farms for Grid Disturbance Studies", Renewable Energy, 33 (2008) 2109–2121.

نمذجة ومحاكاة لمولدات الطاقة من الرياح بأستخدام ماتلاب-سيميونك

م.م. روشن طارق احمد

roshen62@yahoo.com

الجامعة التكنولوجية

م. مهدي علي عبد الحسين

mahdiobaydi@yahoo.com

الجامعة التكنولوجية

المستخلص:

نتيجة لطلب المتزايد على استخدام الطاقة الكهربائية في كافة مجالات الحياة فإن استخدام مولدات الطاقة الكهربائية بواسطة الرياح في زيادة أيضا نتيجة سهوله الحصول على الرياح وعدم تأثر البيئة بها أي انه مصدر نظيف ومتوفر للطاقة. في هذا البحث تمت دراسة منظومة رياضية لتحليل ومحاكاة العوامل المؤثرة على الطاقة الكهربائية المتولدة من مولدات الطاقة من الرياح مثل سرعة الريح والتي تكون متغيرة نتيجة تغير درجة الحرارة والتي تؤدي الى تغيير كثافة الهواء وبدورها تتولد الرياح، زاوية تثبيت الريشة أو الزعنفه. أن دراسة وتحليل وتمثيل لتلك المولدات لها دور كبير في تصميم وتطوير وزيادة كفاءه عمل تلك المولدات. لغة البرمجة ماتلاب سميونك في السنوات الماضية أصبحت أكثر شيوعا في تحليل و تمثيل مختلف أنواع المنظومات لما لها من قابلية التمثيل الرياضي وكمنظومات سيطرة وسهولة التنفيذ وإجراء الاختبارات عليها في مختلف الحالات. دراسة مولدات الطاقة من الرياح وتحليلها هو خير مثال على استخدام لغة البرمجة ماتلاب كونها تحتوي على العديد من المنظومات الفرعية مثل الرياح، رأس التوليد، المنظومات الكهربائية والشبكة الكهربائية. الكلمات الرئيسية: توربينات الرياح، ماتلاب سميونك، الطاقة البديلة.