

## **STUDY AND DETERMINATION OF SAFETY FACTORS WHEN USING CO<sub>2</sub> LASER**

Firas Faeq Al-Araaji

Department of physics, College of science, Al-Muthana University

### **ABSTRACT:**

The use of lasers by industry and by the academic community continues to increase. Many educational institutions are using a wide variety of lasers in many different ways. Traditional disciplines in universities, colleges and high schools, such as biology, chemistry, and physics, now recognize the laser as an essential teaching element. Unique environments associated with educational institutions (such as civil engineering, earth and planetary sciences, and biomedical research) have also incorporated lasers into their educational processes.

The effects of CO<sub>2</sub> laser hazard on different parts of human body (such as eye and skin) have been studied, where hazards are classified into direct and indirect exposure of laser radiation.

The nominal hazard zone has been calculated; it was compared with power and the maximum permissible exposure and found that the nominal hazard zone was direct proportional to power and inverse proportional to maximum permissible exposure.

The optical density has been calculated; it is also compared with maximum permissible exposure and found that the optical density was inverse proportional to the maximum permissible exposure.

### **الخلاصة:**

إن استخدام الليزر في الصناعة والأوساط الأكاديمية في تزايد مستمر. إذ أن الكثير من المؤسسات التعليمية تستخدم مجموعة متنوعة واسعة من الليزر بطرق مختلفة. الكثير من التخصصات التقليدية في الجامعات والكليات والمدارس الثانوية، مثل علم الأحياء والكيمياء، والفيزياء، تستخدم الليزر كعنصر أساسي في التدريس. خلال هذا البحث تم دراسة آثار مخاطر شعاع الليزر (CO<sub>2</sub>) على أجزاء مختلفة من جسم الإنسان (مثل العين والجلد)، حيث يتم تصنيف المخاطر لأشعة الليزر إلى تعرض مباشر وغير مباشر. وقد حسبت منطقة الخطر الاسمية؛ وتم مقارنتها مع القدرة والحد الأقصى المسموح به للتعرض ووجد أن منطقة الخطر المباشر الاسمية كانت متناسبة طردياً مع قدرة الليزر، وتتناسب عكسياً مع التعرض الأقصى المسموح به. وقد حسبت الكثافة البصرية، وتم مقارنتها مع التعرض الأقصى المسموح به ووجد أن الكثافة البصرية تتناسب عكسياً مع الحد الأقصى المسموح به للتعرض.

### **1- Introduction:**

Potential hazards related to the use of lasers can generally be divided into primary and secondary hazards. The laser beam itself represents the primary potential hazard, as it can affect humans or objects – in the form of raw beam, focused beam, directly reflected beam, or scattered radiation. Secondary potential hazards are further subdivided into direct and indirect hazards:

- Direct potential hazards are caused by technical components of the laser installation (high voltage, excitation radiation, laser gases, optics).
- Indirect potential hazards are generated by the interaction of the laser beam with materials or the atmosphere.

Indirect potential hazards include the UV-radiation caused by plasma formation, hazardous substances generated during material processing, and also potential ignition of explosive materials and the danger of fire [1] [5].

**2- Type of Hazard when using Lasers:**

**2.1- Beam Hazard**

The laser produces an intense, highly directional beam of light. If directed, reflected, or focused upon an object, laser light will be partially absorbed, raising the temperature of the surface and/or the interior of the object, potentially causing an alteration or deformation of the material [2].

**2.2- Non-Beam Hazard**

In addition to the direct hazards to the eye and skin from the laser beam itself, it is also important to address other hazards associated with the use of lasers. These non-beam hazards, in some cases, can be life threatening, e.g. electrocution, fire, and asphyxiation. The only fatalities from lasers have been caused by non-beam hazards. Some of these hazards are [2]:

1. Electrical hazards.
2. Chemical hazards.
3. Explosion hazards.
4. X-rays hazards.
5. UV and Visible Radiation hazards.
6. Fire hazard.
7. Cryogenic liquids hazards.
8. Noise hazards.

**3- Maximum Permissible Exposure (MPE):**

In order to know how much exposure, laser light is hazardous the output characterize of laser must be taken in to account. Those characteristics include wavelength, output energy and power, size of the irradiated area, and duration of exposure. If one using a pulsed laser, the pulse repetition rate must be considered. Sensitivity to a given wavelength varies significantly from person to person. Maximum permissible exposure (MPE) limits indicate the greatest exposure that most individuals can tolerate without sustaining injury. An MPE is usually expressed in terms of the allowable exposure time (in seconds) for a given irradiance (in watts/cm<sup>2</sup>) at a particular wavelength. Table (1) gives the maximum permissible exposure for the eye for a variety of lasers operating at different irradiance levels [7]:

**Table (1): MPE for Selected Lasers and Exposure Times [7].**

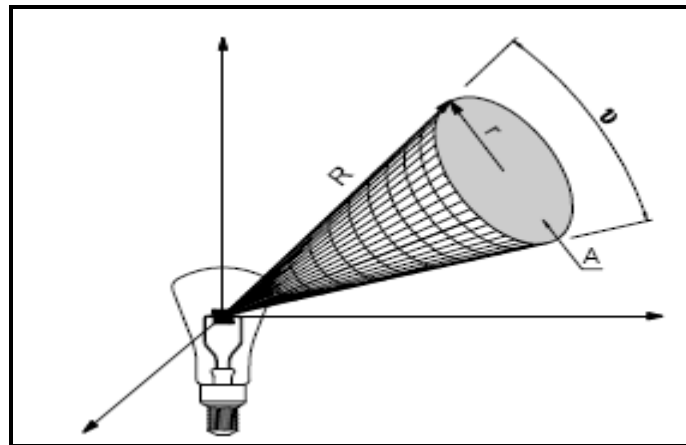
Laser Type	Wavelength (μm)	MPE (average power density-watts/cm <sup>2</sup> )			
		Exposure time in second			
		0.25 s	10 s	600 s	3 x 10 <sup>4</sup> s
CO <sub>2</sub>	10.6	-	0.1 W/cm <sup>2</sup>	-	0.1 W/cm <sup>2</sup>
Nd:YAG (cw)	1.33	-	5.1 x 10 <sup>-3</sup>	-	1.6 x 10 <sup>-3</sup>
Nd:YAG(cw)	1.064	-	5.1 x 10 <sup>-3</sup>	-	1.6 x 10 <sup>-3</sup>
Nd:YAG(cw) Q-switched <sup>b</sup>	1.064	-	17 x 10 <sup>-3</sup>	-	2.3 x 10 <sup>-6</sup>
GaAs (diode)	0.840	-	1.9 x 10 <sup>-3</sup>	-	610 x 10 <sup>-6</sup>
InGdAlP (diode)	0.670	2.5 x 10 <sup>-3</sup>	-	-	-
He-Ne	0.633	2.5 x 10 <sup>-3</sup>	-	293 x 10 <sup>-6</sup>	17.6 x 10 <sup>-6</sup>
Krypton	0.647	2.5 x 10 <sup>-3</sup>	-	364 x 10 <sup>-6</sup>	28.5 x 10 <sup>-6</sup>
	0.568	2.5 x 10 <sup>-3</sup>	-	31 x 10 <sup>-6</sup>	18.6 x 10 <sup>-6</sup>
	0.530	2.5 x 10 <sup>-3</sup>	-	16.7 x 10 <sup>-6</sup>	1.0 x 10 <sup>-6</sup>
Argon	0.514	2.5 x 10 <sup>-3</sup>	-	16.7 x 10 <sup>-6</sup>	1.0 x 10 <sup>-6</sup>
XeFI <sup>c</sup>	0.351	-	-	-	33.3 x 10 <sup>-6</sup>
XeCl <sup>c</sup>	0.308	-	-	-	1.3 x 10 <sup>-6</sup>

**4- Nominal Hazard Zone (NHZ):**

Another quantity of interest in laser safety is called the nominal hazard zone (NHZ). This zone describes the region within which the level of direct, reflected, or scattered (diffuse) laser radiation is above the allowable MPE (figure 1) [6].

To take the right measures for Laser safety reasons one has to know the intensity of the considered light source for a given distance. When this intensity is below the MPE value there will be no risk for damaging the eye.

The intensity is defined as the flux of radiation passing a cross section of  $1\text{cm}^2$ . The flux of radiation is measured in Watts and can be either measured or one trusts the manufacturer of the particular light source or laser. Another definition of the intensity is quite often used as radiation namely the flux per solid angle  $d\Omega$  [6].



**Figure (1):** shows divergence of laser radiation [6].

The frequently used expression, “solid angle  $d\Omega$ ” will be clarified once again with the help of Figure (1). The solid angle  $d\Omega$  is defined as the ratio of the spherical surface  $A$  to the total surface of the sphere of radius  $R$  [6]:

$$d\Omega = \frac{A}{4\pi \cdot R^2} \tag{1}$$

For  $A = 1\text{ m}^2$  and  $R = 1\text{ m}$  (unit sphere) we get the unit of the solid angle, the steradian sr where  $1\text{sr} = 1/4\pi$ .

The solid angle 1sr cuts a cone out of the unit sphere with an angle  $\nu$ . If the surface of the corresponding spherical section is approximated by the circular surface ( $\pi r^2$ ) we get with

$$A = \pi r^2 \tag{2}$$

For  $A = 1\text{ m}^2$

$$r = \frac{1}{\sqrt{\pi}} \tag{3}$$

and for  $\nu$  :

$$\sin\left(\frac{\nu}{2}\right) = \frac{r}{R} = \frac{1}{\sqrt{\pi}} \tag{4}$$

or  $\nu \cong 34^\circ$

The light that passes by the solid angle unit is called radiant intensity ( $I_e$ ) and is measured in  $\text{W/sr}$ . To measure the radiant intensity in  $\text{Wsr}^{-1}$ , it is necessary to know the solid angle used during the measurement. A diaphragm (shown in figure 2) with a radius  $r$  is used for this purpose and a distance  $R$  to the radiator is selected. The solid angle  $d\Omega$  for this arrangement is therefore [6]

$$d\Omega = \frac{\pi \cdot r^2}{4 \cdot \pi \cdot R^2} = \frac{1}{4} \cdot \frac{r^2}{R^2} \tag{5}$$

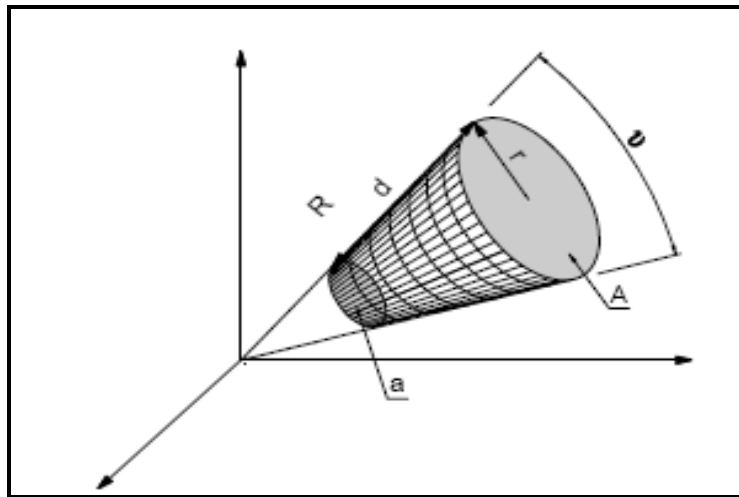
If the total emitted radiation into the full solid angle is known, the flux ( $P_e$ ) through the diaphragm will be [6]:

$$P_e = P_\Omega \cdot \frac{d\Omega}{\Omega} = P_\Omega \cdot \frac{1}{4\pi} \cdot \frac{A_d}{A_r} \quad (6)$$

and the intensity:

$$I_e = \frac{P_e}{A_d} = P_\Omega \cdot \frac{1}{4\pi} \cdot \frac{1}{A_\Omega} = P_\Omega \cdot \left(\frac{1}{\pi \cdot R}\right)^2 \quad (7)$$

From Eq. 2 we can deduce, that for a fixed aperture the intensity will decrease inverse quadratically with increasing distance R from the light source [6].



**Figure (2):** Surface emitter [6].

From the surface a light source emits the power  $P_0$ . In point of view of laser safety we have to know the intensity at a distance d where for instance the eye of the observer is located. The intensity at the surface is simply [8]

$$I_s = \frac{P_0}{a} \quad (8)$$

and the intensity at the distance d will be:

$$I_d = \frac{P_0}{A} \quad (9)$$

Commonly the cross section a as well as the beam radius  $r_a$  is known and we have to derive an expression for A [8].

Since

$$r_A = r_a + 1 \cdot \tan\left(\frac{\nu}{2}\right) \quad (10)$$

the intensity  $I_d$  will be found :

$$I_d = \frac{P_0}{\pi \cdot (r_a + 1 \cdot \tan(\frac{\nu}{2}))^2} \quad (11)$$

If we consider the case of Laser beam, we know that the divergence or the angle  $\nu$  is fairly smaller than  $15^\circ$ . In this case we can use the approximation [9]

$$E = \frac{\tan(\nu) \cong \frac{\nu}{4 \cdot P_0}}{\pi \cdot (d_0 + z \cdot \theta)^2} \quad (12)$$

A Laser can be considered as safe when for each distance  $z$

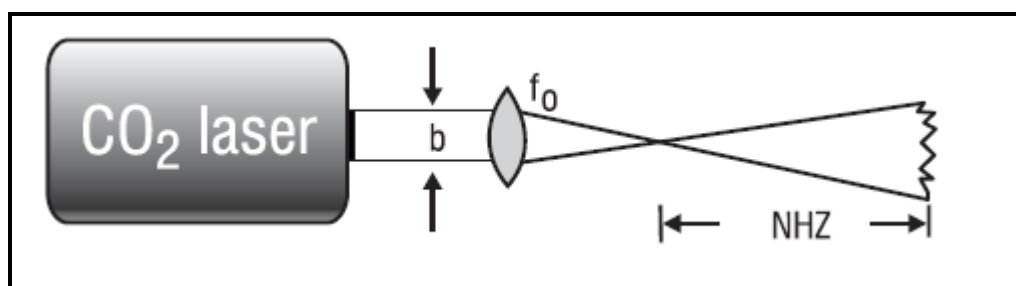
$$MPE \leq E \tag{13}$$

For a particular Laser the MPR is taken from Table (1). With the specification given by the supplier the value for E is calculated using the power, the beam diameter at the beam exit, the divergence and the location for which the Eq. 13 must be fulfilled. It may happen that Eq. 13 is only true for a certain distance  $z$ . The minimum of the distance where the Laser can be considered as safe is termed as nominal ocular hazard distance or as NOHD. This value can be derived from Eq. (12) and Eq. (13) as [10]:

$$Z_{NOHD} = \frac{1}{\theta} \cdot \left( \sqrt{\frac{4P}{\pi \cdot MPE}} - d_o \right) \tag{14}$$

If a negative value for  $z_{NOHD}$  is obtained, the laser is safe and means total safety for each distance. The NHZ for a laser of given power and exit beam diameter is given by the formula [10]:

$$NHZ = \frac{f_o}{b} \sqrt{\frac{4P}{\pi \cdot MPE}} \tag{15}$$



**Figure (3):** Nominal Ocular Hazard Distance [9].

Equation (15) shows how to calculate an NHZ for a given laser and given MPE. Table (2) lists nominal hazard zones for three common lasers, for a direct laser beam, a laser with a focusing lens attached, and diffusely scattered laser light. The data used in the NHZ calculations for the three lasers listed in Table (2) are given in Table (3) [3] [4].

**Table 2:** Nominal Hazard Zones (NHZ) for Various Lasers [3].

Laser Type	Exposure Duration	Nominal Hazard Distance (m)		
		Direct	Lens-on-Laser	Diffuse
Nd:YAG	8 h	1410	11.4	1.4
	10 s	790	6.4	0.8
CO <sub>2</sub>	8 h	399	5.3	0.4
	10 s	399	5.3	0.4
Argon	8 h	25 , 200	1700	12.6
	0.25 s	505	33.6	0.25

**Table 3:** Laser Criteria Used for NHZ Calculations [3]

Laser Parameter	Nd:YAG	CO <sub>2</sub>	Argon
Wavelength, $\lambda$ ( $\mu\text{m}$ )	1.064	10.6	0.488 , 0.514
Beam power, $P$ (W)	100	500	5.0
Beam divergence, $\phi$ (mrad)	2.0	2.0	1.0
Beam size at aperture, $a$ (mm)	2.0	20.0	2.0
Beam size at lens, $b$ (mm)	6.3	30.0	3.0
Lens focal length, $f_o$ (mm)	25.4	200	200
MPE, 8 hour ( $\mu\text{W}/\text{cm}^2$ )	$1.6 \times 10^3$	$1.0 \times 10^5$	1.0
MPE, 10 s ( $\mu\text{W}/\text{cm}^2$ )	$5.1 \times 10^3$	$1.0 \times 10^5$	-
MPE, 0.25 s ( $\mu\text{W}/\text{cm}^2$ )	-	-	$2.5 \times 10^3$

## 5- Simulation Results & Discussions:

### 5.1- Input Parameters

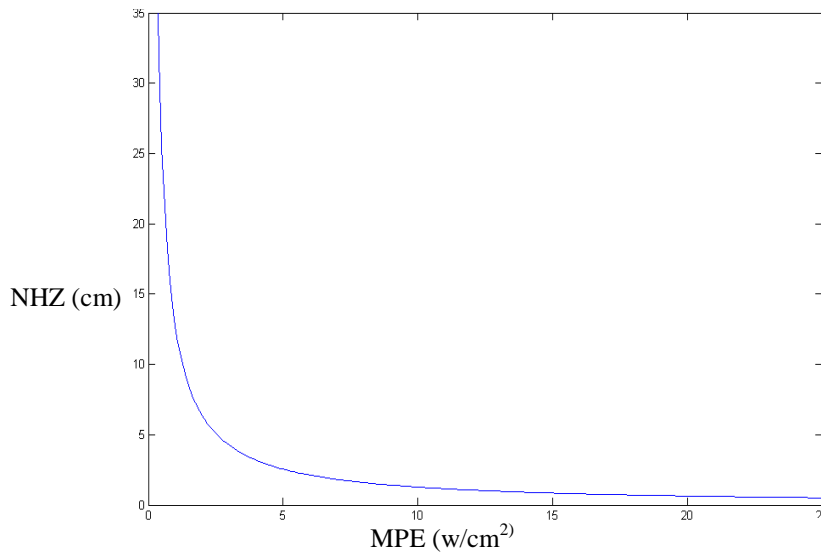
There are some input parameters for laser system. These parameters can be arranged in table (4) bellow

**Table (4):** Input parameters [10].

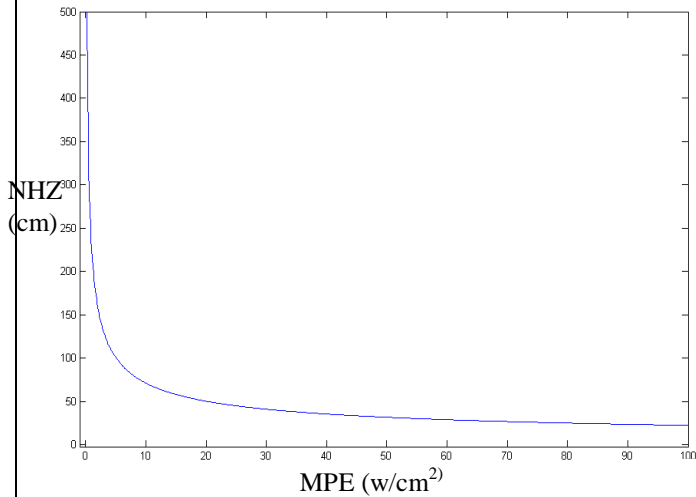
Laser type	CO <sub>2</sub> laser
Power (P)	1,100,1000 (w)
Wavelength ( $\lambda$ )	10.6 ( $\mu\text{m}$ )
Beam diameter (b)	1 (cm)
Focal length ( $f_o$ )	20 (cm)
maximum permissible exposure (MPE)	0.1-100 W/cm <sup>2</sup>

### 5.2- Calculation of Nominal Hazard Zone (NHZ)

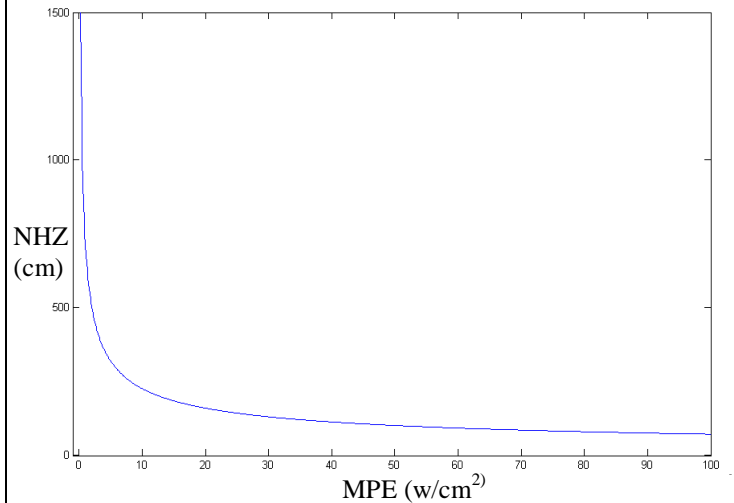
By using the equation (15), the Nominal Hazard Zone (NHZ) has been calculated. According to the equation recorded above, the relationship between the (NHZ) and Maximum permissible exposure (MPE) (with values of power are 1, 100 and 1000 W respectively) were shown in figures (4, 5, and 6) bellow:



**Figure (4):** Relationship between (NHZ) and (MPE) with value of P=1W.



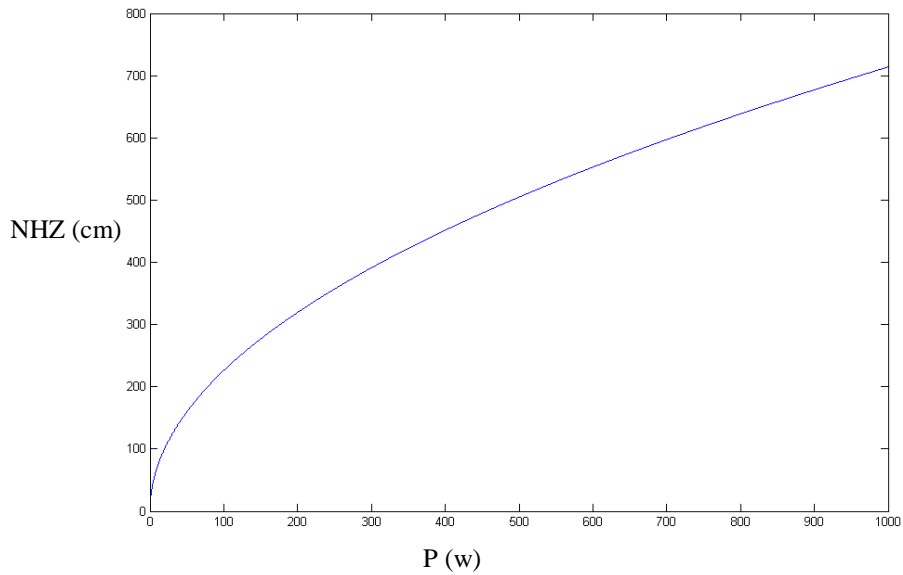
**Figure (5):** Relationship between (NHZ) and (MPE) with value of P=100W.



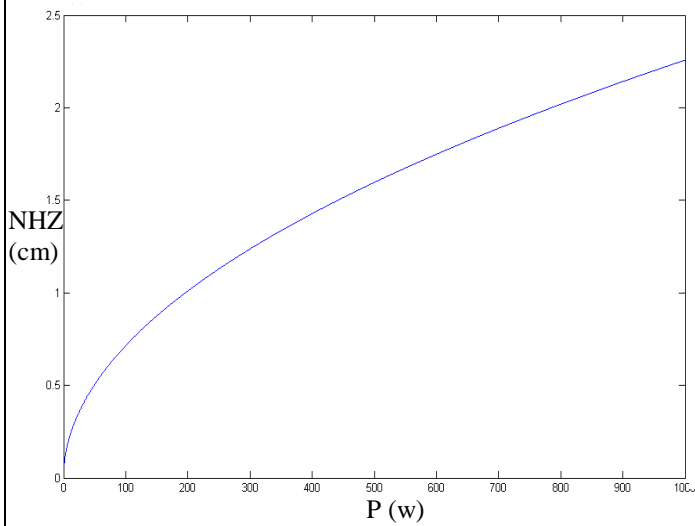
**Figure (6):** Relationship between (NHZ) and (MPE) with value of P=1000W.

From the figures above, we can notice that the relation between the Nominal Hazard Zone (NHZ) and Maximum permissible exposure (MPE) is inversely proportional.

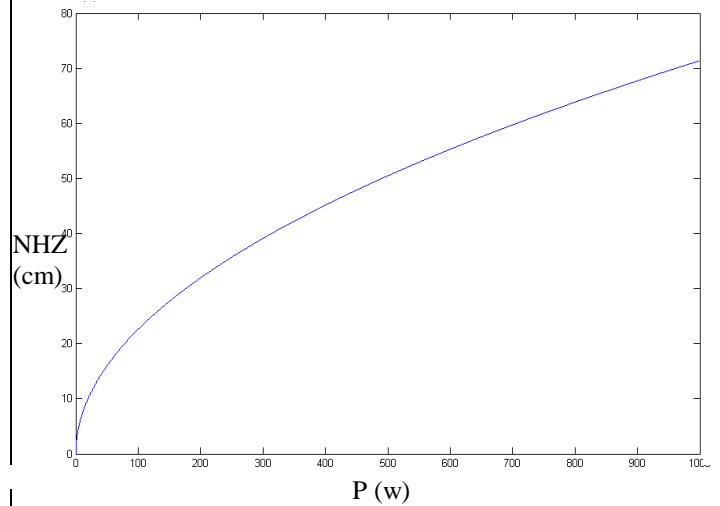
The relationship between the (NHZ) and the power (P) (with values of MPE is 1, 10 and 100 W/cm<sup>2</sup> respectively) were shown in figures (7, 8, and 9) below:



**Figure (7):** Relationship between (NHZ) and (P) with value of MPE=1 W/cm<sup>2</sup>.



**Figure (8):** Relationship between (NHZ) and (P) with value of MPE=10 W/cm<sup>2</sup>.

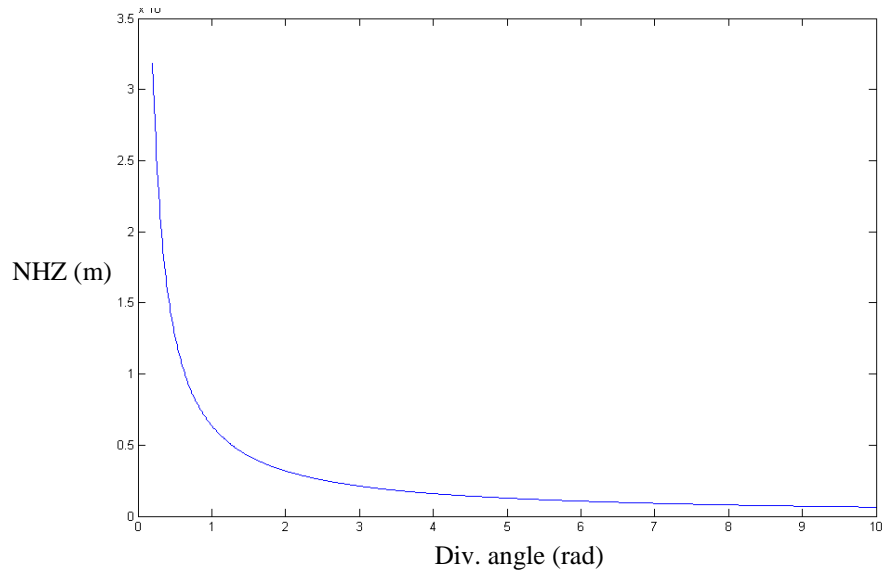


**Figure( 9):** Relationship between (NHZ) and (P) with value of MPE=100 W/cm<sup>2</sup>.

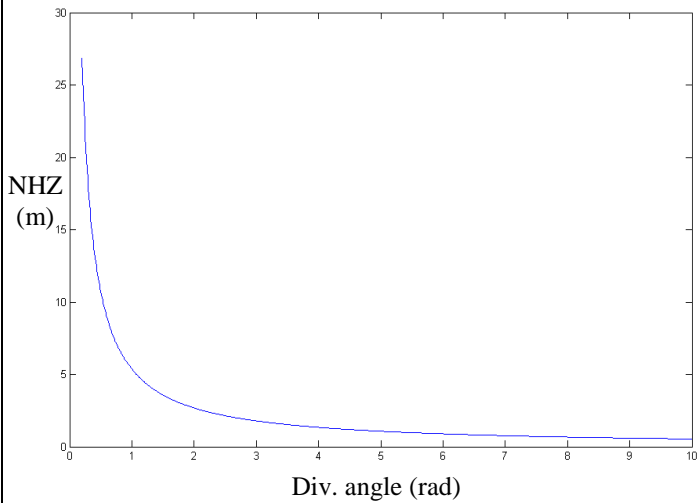
From the figures (7, 8, and 9) above, we can notice that the relation between the Nominal Hazard Zone (NHZ) and power (P) is directly proportional.

According to equation (14), the relation between the (NHZ) and the divergence angle ( $\theta$ ) (with values of power are 1, 100 and 1000 W respectively) were shown in figures (10-12) bellow:

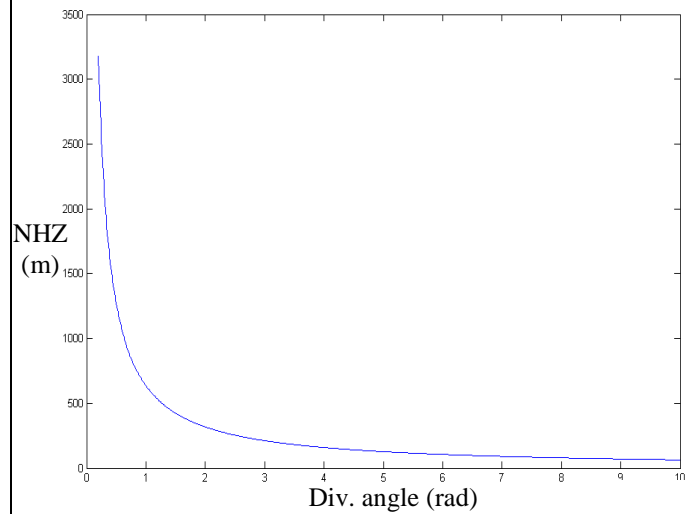




**Figure (10):** Relationship between (NHZ) and ( $\theta$ ) with value of P=1W.



**Figure(11):** Relationship between (NHZ) and ( $\theta$ ) with value of P=100W.

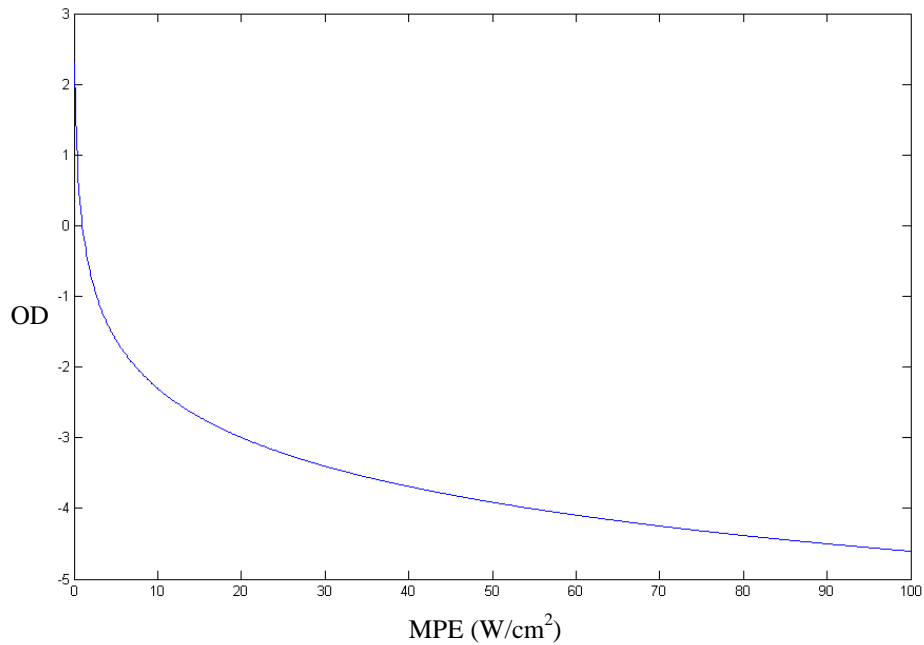


**Figure (12):** Relationship between (NHZ) and ( $\theta$ ) with value of P=1000W.

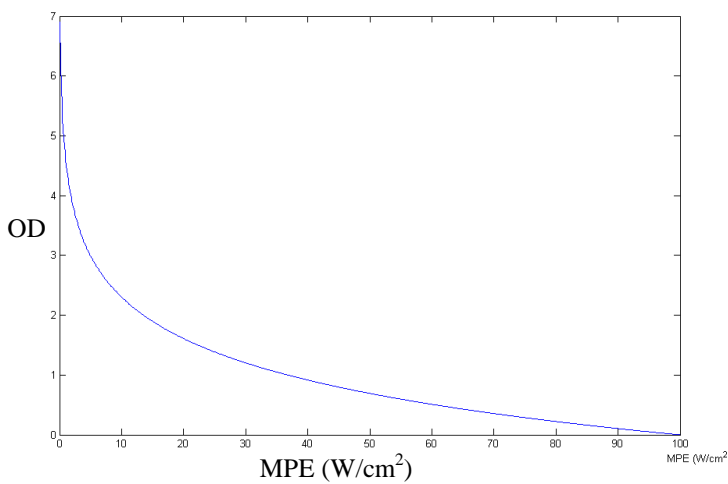
From the figures (10-12) above, we can notice that the relation between the Nominal Hazard Zone (NHZ) and the divergence angle ( $\theta$ ) is inversely proportional.

### 5.3- Calculation of Optical Density (OD):

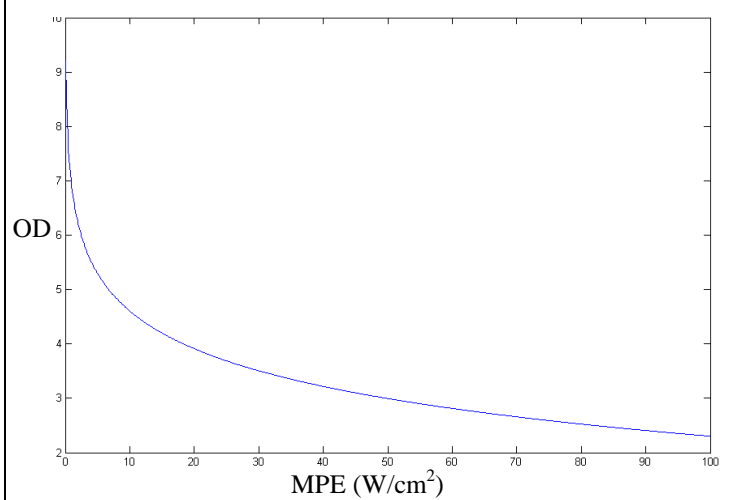
The relationship between the optical density (OD) and the Maximum permissible exposure (MPE) (with values of incident irradiance are 1, 100 and 1000 W/cm<sup>2</sup> respectively) were shown in figures (13-15) bellow:



**Figure (13):** Relationship between (OD) and (MPE) with value of  $E_0=1 \text{ W/cm}^2$



**Figure (14):** Relationship between (OD) and (MPE) with value of  $E_0=100 \text{ W/cm}^2$ .

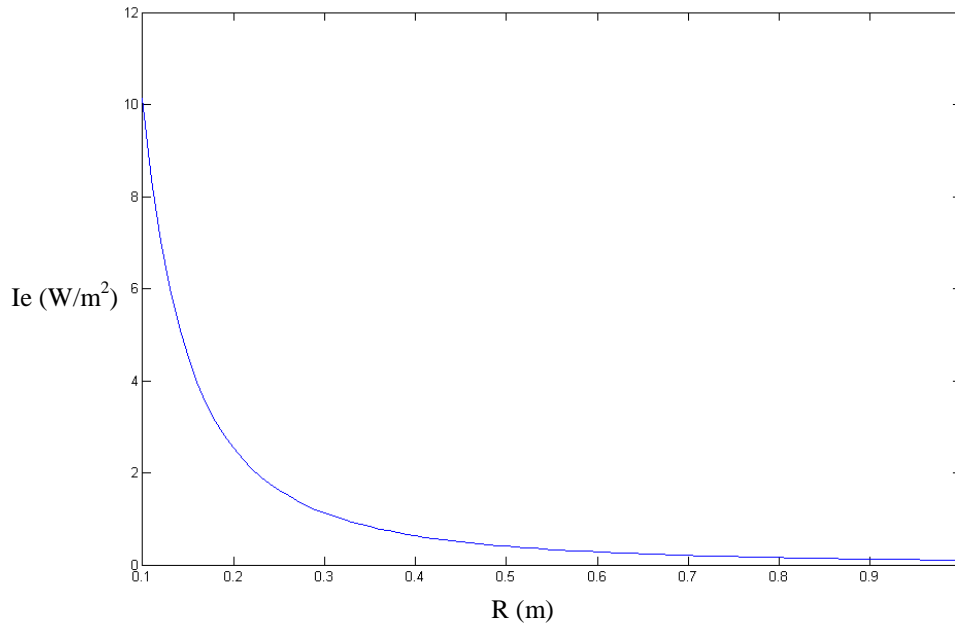


**Figure (15):** Relationship between (OD) and (MPE) with value of  $E_0=1000 \text{ W/cm}^2$ .

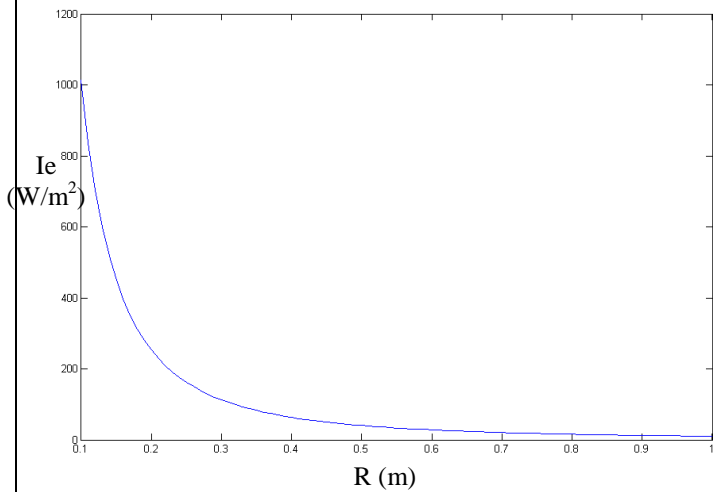
From the figures (13-15) above, we can notice that the relation between the optical density (OD) and the Maximum permissible exposure (MPE) is inversely proportional.

#### 5.4- Calculation of radiant intensity ( $I_e$ )

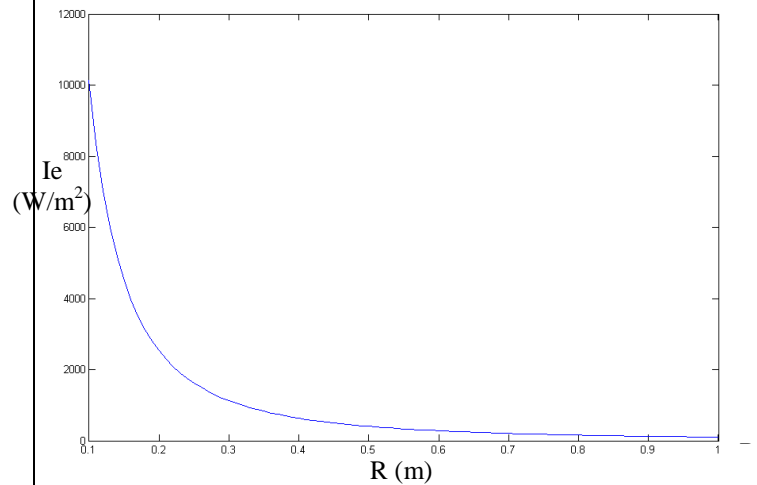
By using the equation (7), the relationship between the radiant intensity ( $I_e$ ) and the distance (R) (with values of power are 1, 100 and 1000 W respectively) were shown in figures (16-18) below:



**Figure (16):** Relationship between ( $I_e$ ) and ( $R$ ) with value of  $P=1$  W.



**Figure (17):** Relationship between ( $I_e$ ) and ( $R$ ) with value of  $P=100$  W.



**Figure (18):** Relationship between ( $I_e$ ) and ( $R$ ) with value of  $P=1000$  W.

From the figures (16-18) above, we can notice that the radiant intensity ( $I_e$ ) and the distance ( $R$ ) inversely proportional.

## **6- Conclusions:**

From this study and according to the results, which have been obtained, the following points can be concluded:

- 1-** The long exposure of radiation to the eye and skin may cause damage to these parts of the human body.
- 2-** The power dose not directly effect on the human body with fixed value of (MPE).
- 3-** The small divergence angle makes the laser safer to the human body.

- 4- The long exposure of the laser on the human body needs to increase the safety equipments of the laser user (such as safety suits, goggles, etc).
- 5- The increasing of (R) makes the work circumstance safer.

**7- References:**

- [1] W. T. Silvast, Laser Fundamentals, Cambridge University press, 2004.
- [2] O. Svelto, Principles of Lasers, Poly Technique Institute of Milan, Italy, 1998.
- [3] W. S. C. Change, Principles of Laser and Optics, 2002.
- [4] CFMO-13, Medical Surveillance of Personal Occupationally Exposed to Hazardous Laser Devices.
- [5] H. Ly, Laser Safety, The University of Western Ontario, 2006.
- [6] W. Luhs, Laser safety, MEOS GmbH 79427 Eschbach, July 2003.
- [7] American National Institute (ANSI), Safe Use of Lasers, Z136.1, 2000.
- [8] M. Varkking, LCVU, Atomic and Molecular Physics, 2002.
- [9] Northwestern University, Laser Safety Handbook, 2007.
- [10] A. Kis, Laser Safety, Ernest Orlando Lawrence Berkely National Laboratory, Material Science Division, 2006.
- [11] South Dakota School and Mines Technologies, University of North