

THEORETICAL STUDY OF ALARM SYSTEM FOR BLIND MAN

Issam Haidar Al-Sakini – Assist. Lecturer - Institute of Medical
Technology/Mansoure
Issamalsakini@yahoo.com

ABSTRACT

In This paper we discussed the usage of ultrasonic sensor to alerts a blind man from hitting an object depending on the principle of SONAR and generate an audible signal to alert the blind man that there is an object in front of him at a detection range (0.31- 3.1) m. The device could be mounted at the belt of the blind man. The ultrasonic pulses is transmitted by transducer, this pulse reflects off an object is received by another transducer. We use the 40 kHz ultrasound transducer enabling the same transducer to be used both as a transmitter and as a receiver . The sound waves frequency which is used beyond our range of hearing (human hearing is between 20Hz – 20kHz) . By using the known speed of the sound wave (346.3 m/s) and the time between the transmitted pulse and the received pulse we could calculate the distance. The determination of the distance will depend on two modes of operation (calibration mode and speed detection mode) , The calibration mode is useful because the sound wave speed varies with altitude and the atmospheric conditions , while the speed detection mode is useful to determine the speed of the user moving toward or away from an object .

KEYWORD

Sonar – sound navigation and ranging , Transducer – device which converts voltage signal to sound wave and vice versa , Q – Quality Factor , US Tx – ultrasonic transmitter , US Rx – ultrasonic receiver .

أخلاصه :

يتم في هذا البحث مناقشته استخدام متحسسات الامواج فوق الصوتيه لمساعدة الضريير على تجنب الاصطدام بالاجسام التي تصادفه على الطريق أعتامادا على مبدأ السونار والذي يقوم بتوليد الاشارات الصوتيه والتي تمكن الضريير من تجنب الاصطدام بالاجسام التي تصادفه من الامام على مدى (0.31 – 3.1) متر , الجهاز يمكن ربطه الى حزام الرجل الضريير . الموجات فوق الصوتيه يتم بثها بواسطه المشع , هذه الموجات تتردد من الاجسام الصلبه ويتم أستلامها بواسطه المستلم , في هذا البحث أستخدما مشع و مستلم يعمل بتردد مقداره (40 kHz) , بسبب كون الموجات الصوتيه والتي تقع ضمن مدى الموجات الصوتيه المسموعه هي (20 – 0.2) kHz . من خلال معرفتنا بسرعه الموجات الصوتيه والتي تساوي (346.3) m/sec والزمن بين النبضه المرسله و النبضه المستلمه يمكننا حساب المسافه . حساب المسافه يعتمد على نظامين الاول نظام التعيير والنظام الثاني سرعه الكشف . النظام الاول مفيد جدا لكون سرعه الموجات الصوتيه تتغير نسبه الى الارتفاع و المتغيرات الجويه , بينما النظام الثاني يكون مفيد في حساب سرعه المستخدم باتجاه الجسم الصلب او عكس الاتجاه .

1. INTRODUCTION

We know that the speed represents the first derivative ($\frac{dx}{dt}$ - dx is the change in distance , dt - change in time) and also that the distance between the user and the object is multiple by 2 (since the sound wave travels in one direction, is reflected and travels back in the other direction) . In this research. we can determine the extent of the variations in object strength TS for a specific object in a given environment by measuring the changes in the magnitudes of echoes from the object for a series of pulses at all expected variations reradiating objects , The echo level as a function of object range is[1] :

$$Elf (R) = SPL (R0) - 40 \log (R/R0) - 2 \alpha f R + TS \dots\dots\dots (1)$$

Where :

Elf (R) – Echo level at frequency f , R – Range distance to target , SPL (R0) – Sound pressure level of transmitter at reference distance R0 , α f – attenuation coefficient of sound at frequency f , TS – object strength

Changes in temperature will cause a variable error in the accuracy of the absolute distance measurement for a 1° C temperature change of :

$$\text{err Rin (R)} = 0.0017 \dots\dots\dots (2)$$

$$\text{err Rft (R)} = 0.0204 \dots\dots\dots (3)$$

Where :

err Rin (R) - variable error in object range in inches for a 1° C , err Rft (R) - variable error in object range in feet for a 1° C [2] .

There are many factors which affects the measurements of the range of the object such as : the shape of the object , the distance between the sensor and the object must be adequate , the cross-section of the object must be enough to reflect the sound wave, object must be set in front of the ultrasonic sensor in order to detect the desired object and ignore the all the objects outside this area , a lower frequency of sensor will detect longer ranges and vice versa , attenuation of the sound , and humidity as in the Fig below. [3]

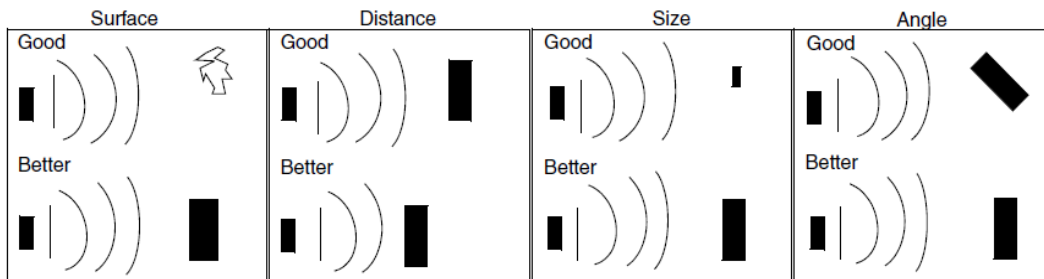

2 . EXPERIMENTAL VALIDITION

2.1 General Description

Note : we use the program (National Insrument electronic's workbench Multisim 10.0) to perform this research .

The ultrasonic transmitter (US Tx) sends a sound wave through the air by using 40kHz piezoelectric transducer . This wave is reflected from the object and received by ultrasonic receiver (US Rx) .In this paper we treat the air as an ideal gas where the speed of sound is a function of temperature and it can be calculated:

$$C = \sqrt{\gamma R T} \dots\dots\dots (4)$$

Where : C – speed of sound m/s , γ - ratio of specific heats ($\gamma = 1.4$ for dry air) , R – gas constant (R= 286.9 N. m/(kg.K)) , T – absolute temperature (Kelvin – where 0°C = 273.16 K) [4,5] .

For example the speed of sound at room temperature (25°C , 71.6°F) is :

$$C = \sqrt{1.4 (25 + 273.16)(286.9)} = 346.3 \text{ m/s}$$

Fro more details see the table (**change in speed according to Temperature**)

Temperature	Speed
-20° C	319.3 m/s
0° C	331.6 m/s
5° C	334.5 m/s
10° C	337.5 m/s
15° C	340.6 m/s
20° C	343.8 m/s
25° C	346.3 m/s
40° C	355.3 m/s
60° C	366.5 m/s
80° C	377.5 m/s

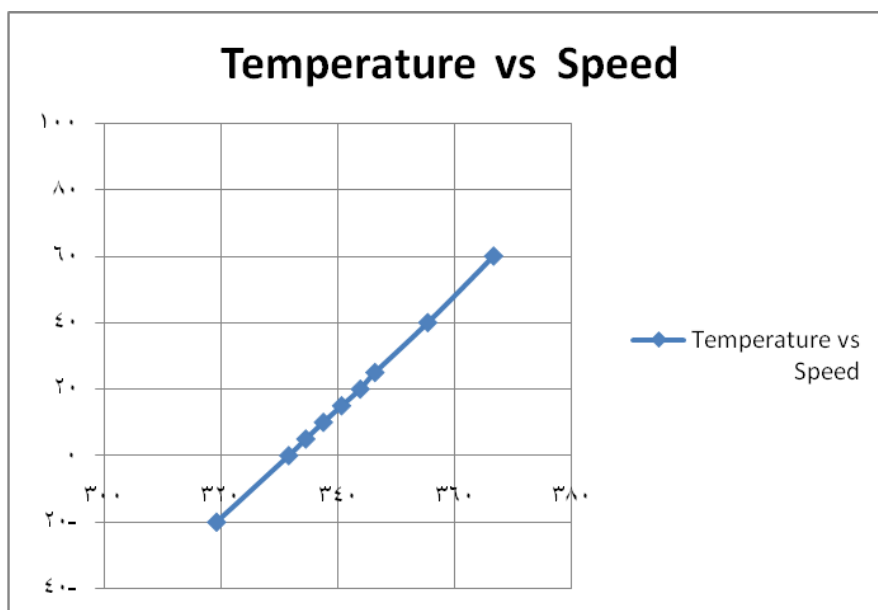

Variation of speed according to temperature

2.2 Schematic Diagram

Using the old version [6] and rebuilding it by Multisim 10.0 software [7] for getting better results and resolution the following work is achived .The ultrasonic device operates on principle similar to radar but operates at ultrasonic frequencies rather than radio frequencies , the ultrasonic transducer transforms an electronic signal to an ultrasonic pulse, transmits the ultrasonic pulse , receives an ultrasonic echo and transforms the ultrasonic echo to an electronic signal (as shown in Fig.1) , or in another terms (sending an ultrasound burst and listening for first echo).

A new burst is generated each time the decade counter U2 (as shown in Fig.2) [8] is in its reset state , the output 0 is selected. The outputs of the decade counter Q1-Q9 are scanned sequentially following the burst generation, until an echo strikes back the receiver USRX .

By adjusting the resistance R9 (as show in Fig.3) we can choose the adequate range , setting this resistance to its minimum value we get the minimum range , which is fed to the clock input of the decade counter (5-stage divide-by-10 Johnson counter with 10 decoded outputs and a carry-out bit as shown in Fig . 2) the frequency of the oscillator is adjustable by the resistor R9 (as shown in table 2) , the frequency can be calculated by using the formula .:

$$f = \frac{1}{T} = \frac{1}{R * c} \dots\dots\dots 5$$

For max value of R9 = 50kΩ the frequency is :

$$f1 = \frac{1}{R * c} = \frac{1}{(50 + 5.6) * 10^3 \Omega * 33 * 10^{-9} F} = 545 \text{ Hz}$$

For min value of R9 = 0kΩ the frequency is :

$$f2 = \frac{1}{R * c} = \frac{1}{(5.6) * 10^3 \Omega * 33 * 10^{-9} F} = 5.411 \text{ kHz}$$

The output of the decade counter pin(3) is a pulse which its frequency is divided by ten :

$$f1 = 54.5 \text{ Hz}$$

$$f2 = 541.1 \text{ Hz}$$

So the duration of the pulse is :

$$T1 = \frac{1}{f1} = \frac{1}{54.5 \text{ Hz}} = 18.35 \text{ msec}$$

$$T2 = \frac{1}{f2} = \frac{1}{541.1 \text{ Hz}} = 1.84 \text{ msec}$$

So the distance from device to the object is calculated from :

$$T = 2 * R / C \dots\dots\dots (6)$$

where R – distance from the device to the object , c- sound speed = 346.3 m/sec

$$\text{So: } R1 = \frac{T1 * c}{2} = \frac{18.35 * 10^{-3} * 346.3 \frac{m}{sec}}{2} = 3.1 \text{ m}$$

$$R2 = \frac{T2 * c}{2} = \frac{1.84 * 10^{-3} * 346.3 \frac{m}{sec}}{2} = 0.31 \text{ m}$$

These pulses controls the oscillator 2 (U3C,R11,R12,C8) which its frequency is set at 40kHz , The oscillator U3C is built around the schmitt trigger (as shown in Fig.4) , resistor R12 is used to set the frequency at 40kHz) [9] , while U3B is a buffer and U3A boots the signal doubling the voltage span across the USTX transducer .The frequency of the oscillator U3C (as shown Fig.3) can be calculated :

$$f1 = \frac{1}{T} = \frac{1}{R * c} = \frac{1}{68 * 10^3 * 330 * 10^{-12}} = 44.5 \text{ kHz}$$

$$f2 = \frac{1}{T} = \frac{1}{R * c} = \frac{1}{(68 + 50) * 10^3 * 330 * 10^{-12}} = 25.6 \text{ kHz}$$

The US Tx sends a beam of sound waves which has more energy on the main lobe and less energy (60dB below the main lobe as shown in Fig.5) on the side lobes , even this low side signal is picked up by the receiver unit , thus we must space the transmitter and the receiver about 5 cm apart . This signal is transmitted through the air and when this signal hit an object, it reflects back , the receiver works during the period while the transmitter is off .The(Fig.6) echo signal received by the receiver sensor US Rx after reflection is very weak , so we use a quad operation amplifier U1A, U1B (as shown in Fig.6) [10] .The received echo is coupled by capacitor C9 and fed to the inverting op - amplifier U1A, U1B, the operation amplifier amplifies the signal , through C3 to

precision rectifier D3, D4 and then to the comparator U1C which its reference level is adjusted by R6 , the next stage is a buffer stage with unity gain U1D .

A buffer or inverter with schmitte – trigger input U3F (as shown in Fig.4)is used in order to have enough drive, and this signal is fed to the enable pine (13) of the decade counter U2 (IC 4017) so the signal will be divided by 2 if the object is in the range of (0.31– 3.1) m the buzzer will produce a sound wave which will alerts the blind man that there is an object in front of him in order to avoid it .

3. RESULTS AND DISCUSSION

All the results are theoretically calculated , For the results see the table

(calculation of distance)

No	R(kΩ)	C(nF)	F=1/T(Hz)	T=R*C(sec)	R=(T*346.3)/2(m)
1	(5.6+50)	33	54.500	0.01834	3.170
2	50	33	60.606	0.01650	2.856
3	45	33	67.340	0.01485	2.570
4	40	33	75.757	0.01485	2.2855
5	30	33	101.0101	0.00990	1.714
6	20	33	151.515	0.00660	1.1427
7	10	33	303.030	0.00330	0.571
8	9	33	336.700	0.00297	0.514
9	8	33	378.787	0.00264	0.457
10	7	33	432.900	0.00230	0.399
11	6	33	505.0500	0.00190	0.342
12	5.6	33	541.125	0.00184	0.319

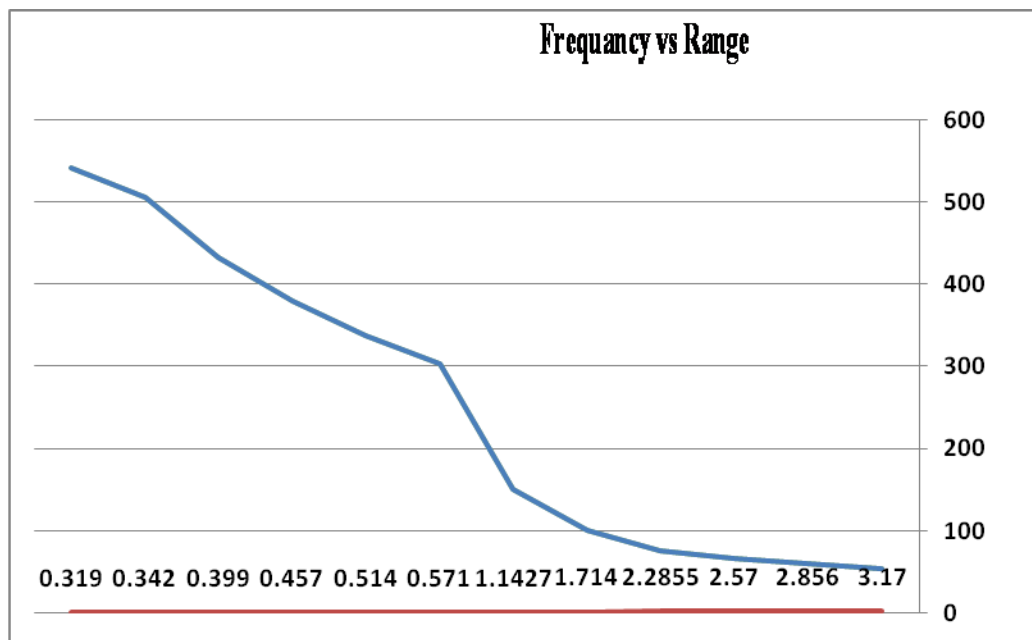

4. CONCLUSIONS

The goal of this research is to protect the blind man from hitting any object in front of him in order to avoid it .The device has advantages :

- 1-The use of integrated circuit which is cheap, available, small size, high response, high efficiency, low power supply, low power dissipation.
- 2-As a modification for the devices we can use the microcontroller unit (MCU) which needs a special software written in C , C⁺⁺ , Assembly language to minimize the size of the device and to minimize the amount of the components , and for a high resolution .

REFERENCES

- 1 . David A. Bell” Electronic Device and Circuits , Oxford University Press 2008, Optimizing Sensor Selection “ Sensors , March 1 , 1999” .
- 2 . Donald P . Massa “Choosing an Ultrasonic Sensor for Proximity or Distance Measurement Part 2 , optimizing sensor selection ,march , 1999 “.
- 3 . Luis Puebla Palma " Ultrasonic Distance Measurer , Freescale Semiconductor ,Document No.AN3481 , Rev.0.02/2008 “.
- 4 . Donald P. Massa “Choosing an Ultrasonic Sensor for Proximity or Distance Measurement Part 1,acoustic considerations ,february ,1999 “.
- 5 . Frank Mas sa May 1992 “Ultra fiftieth Anniversary Issue, Proc IRE “.
- 6 . www.riccibitti.com / Good Old Sonar .
- 7 . National Instruments Circuit Desgin Suit 10.0 (Multisim) .
- 8 .<http://pdf1.alldatasheet.com/view.jsp?searchword=CD4017B&q=CD4017B> .
- 9 . M . E . Frerking “ Crystal Oscillator Design and Temperature Compensation , Van Nostrand Reinhold Company , New York , 1978” .
- 10 . <http://www.google.com/url?sa=web&cd=8&ved=OCDQQFjAH&url> .

APPENDIX

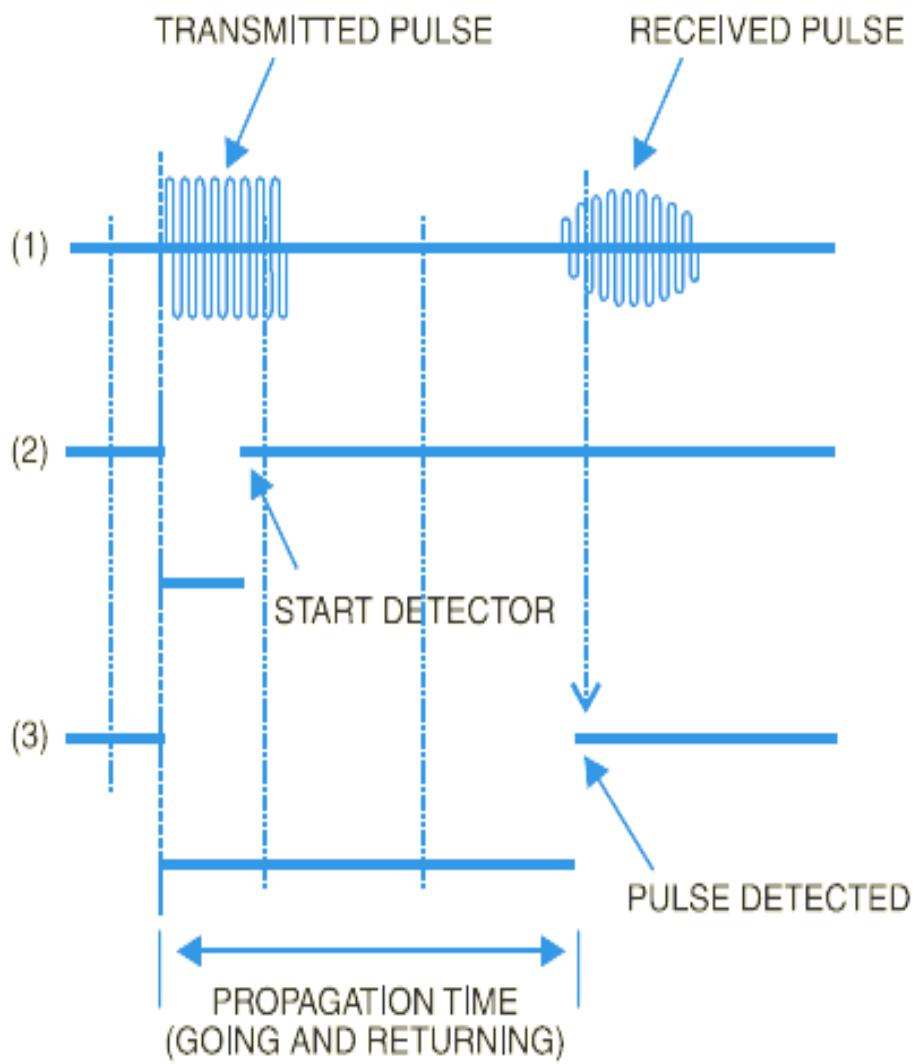
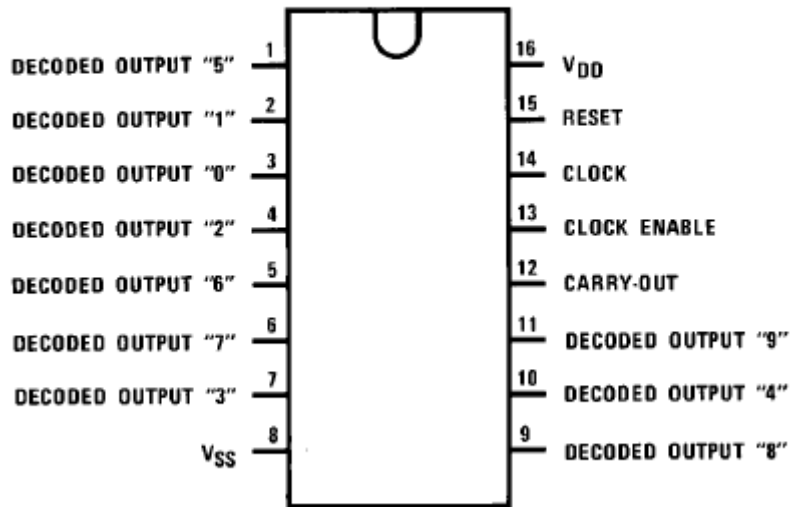

Fig .1(ultrasonic principle)

**CD4017B
Dual-In-Line Package**



TL/F/5950-1

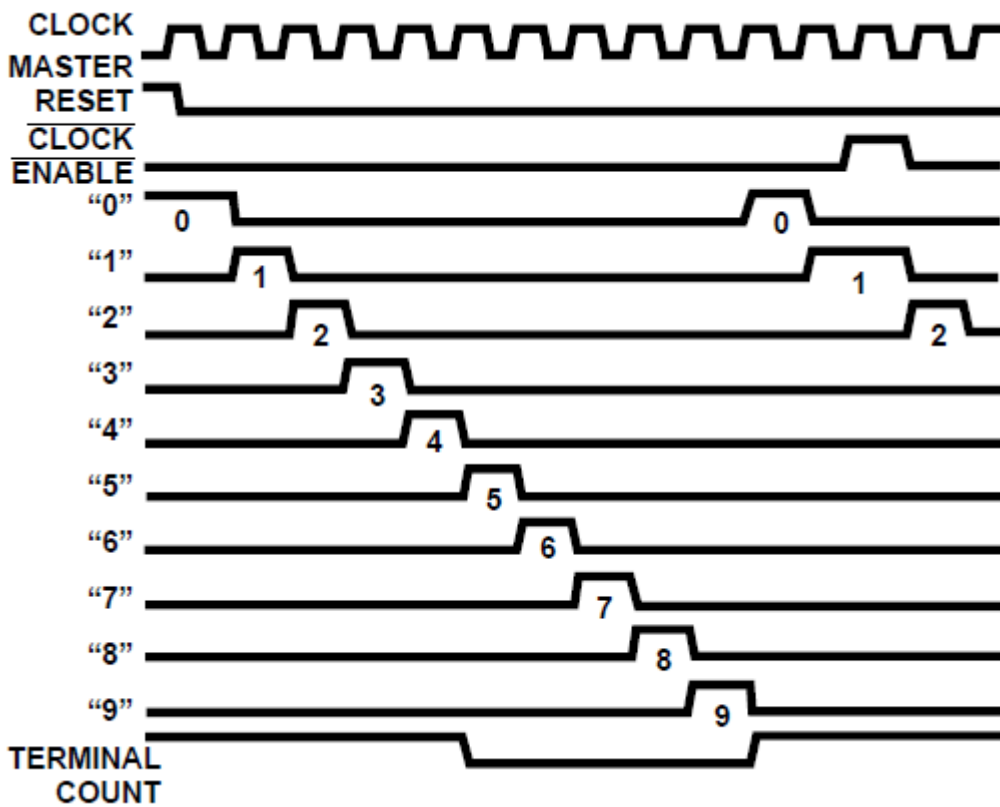

Fig .2 (Layout and Wave form of the signals at the pins of Ic 4017)

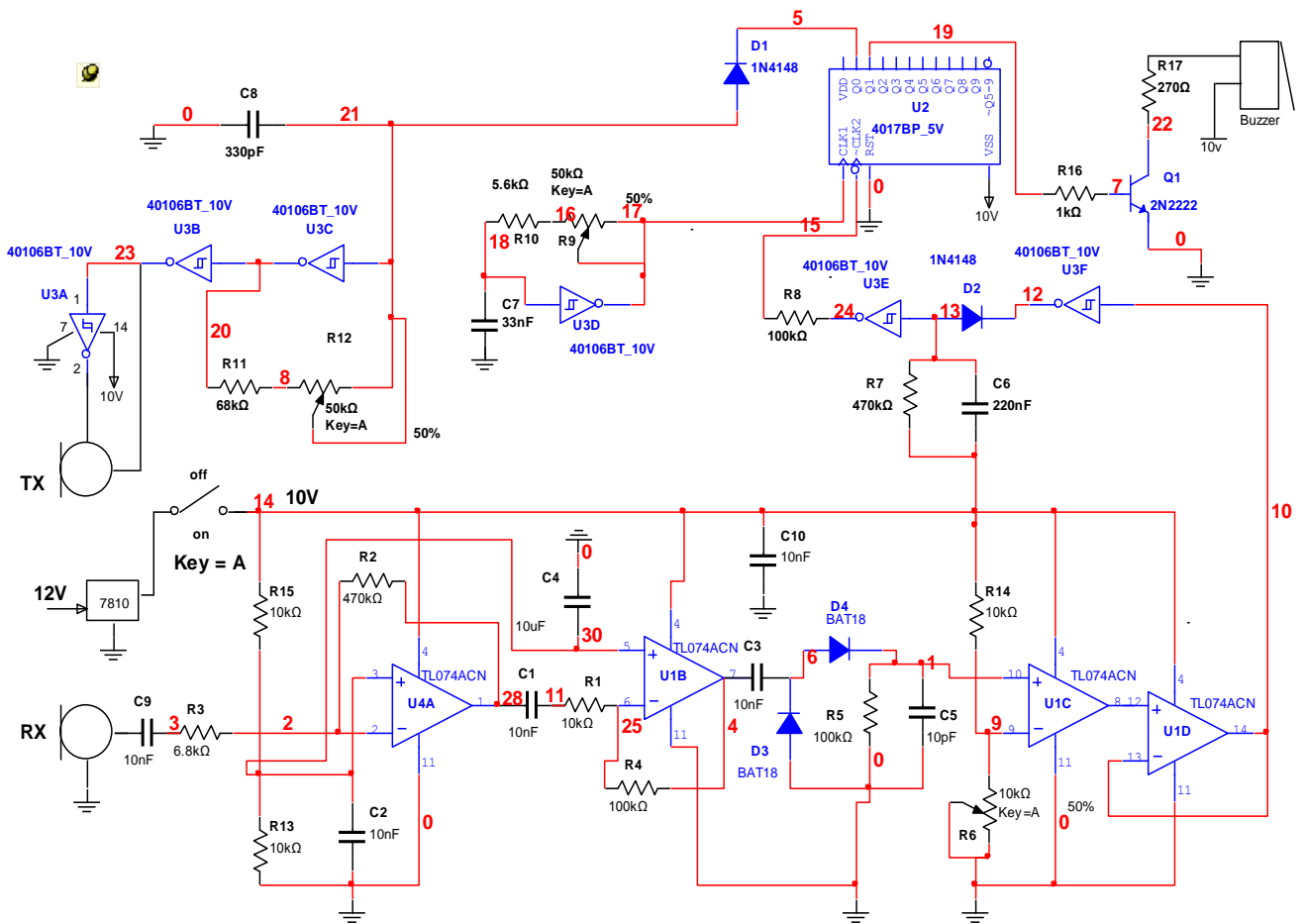

Fig.3 Schematic Diagram of the device

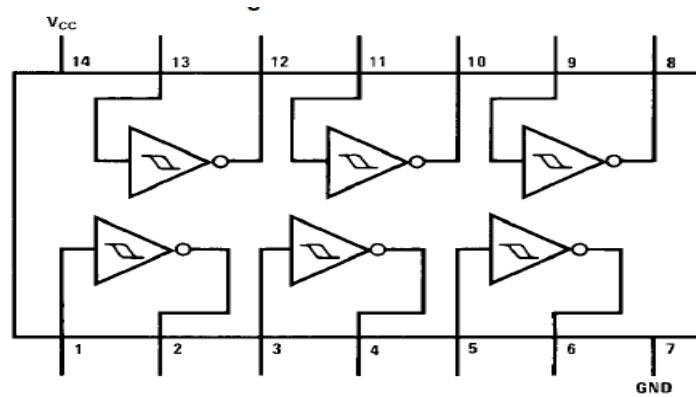

Fig 4 (layout of IC 40106 BT)

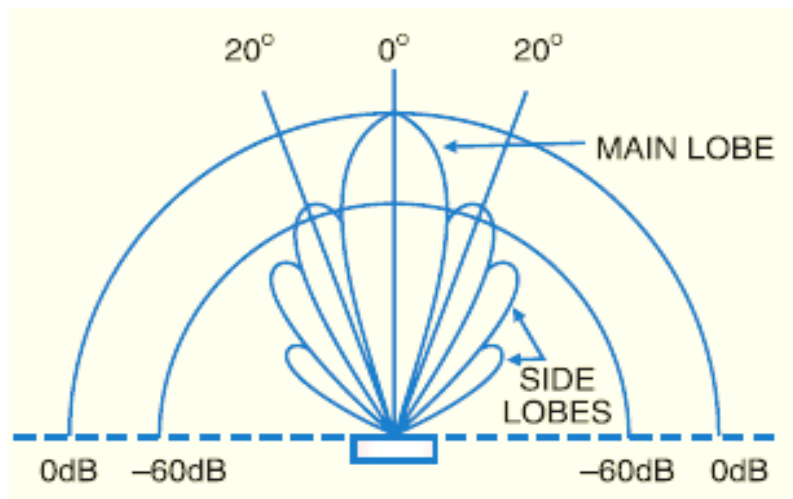

Fig .5 (pattern of the ultrasonic transmitted signal)

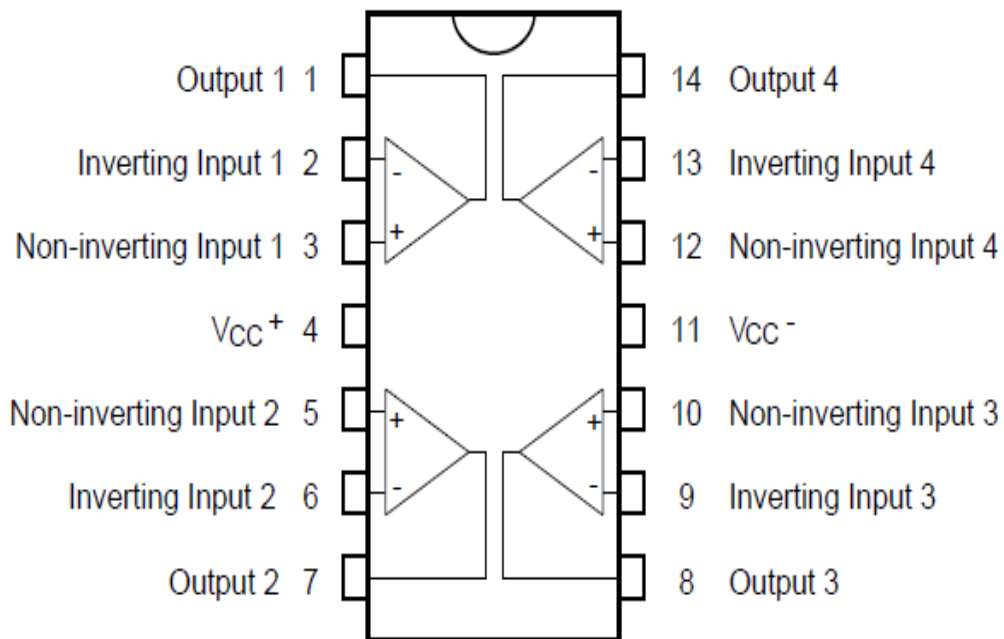

Fig .6 (layout of IC TL074 CAN)