

## **Studying the Total harmonic distortion (THD)for multilevel DC/AC Inverter**

### **دراسة عامل التشويه التوافقي الكلي (THD) لمغيرات DC/AC المتعدد المستوى**

سوسن شريف فليفل \* د. خالد إبراهيم عجيل \* عبدا لكريم خميس حسن\*\*  
\*قسم الفيزياء- كلية التربية –جامعة البصرة-البصرة-جمهورية العراق  
\*\*قسم الهندسة الكترونية والكهربائية-كلية الهندسة-جامعة البصرة- البصرة-جمهورية العراق

#### **Abstract**

This paper presents the generation of sinewave AC voltage from DC battery using Cascaded multilevel inverters connected in series . The concept of multilevel voltage source inverters and their topologies are described. The (Optimising stepped sinewave) technique for a cascaded multilevel inverter is presented to get an ac voltage from a dc power supply in order to decrease the total harmonic distortion in the output voltage of the multilevel inverter by applying two techniques: zero crossing and nonzero crossing for different steps . The optimised harmonic stepped-waveform technique is applied to the multilevel inverter using cascaded-inverters with separated dc sources for 3,5,and 7 nonzero crossing stepped sine wave by using Matlab software . The effect of number of steps on the generated voltage has been analyzed .Total harmonic distortion is decreased by 23.29% for zero crossing stepped and by 22.29% for non-zero crossing stepped.

Key words : Inverter, Zero crossing, non zero crossing, OHSW technique, Low switching frequency, AC and DC voltage, THD.

#### **المستخلص**

أصبح استخدام مغيرات التيار المستمر الى متناوب المتعددة المستوى في السنوات الأخيرة شائعاً في تطبيقات القدرة العالية. هذا البحث يُعنى بدراسة مبدأ التقليل من قيمة التوافقيات والحصول على فولتية متناوبة من مصدر مستمر، حيث تمت دراسة نوعين من الموجات المتدرجة ، الأولى هي ذات التقاطع الصفري والأخرى ذات التقاطع اللاصفرى ، وقد تمت المقارنة بينهما للحصول على أقل قيمة لعامل التشويه الكلي للتوافقيات فبينت الدراسة أن النوع الثاني هو الأفضل من حيث تقليل التشويه في التوافقيات ، أي أن الموجة الخارجة هي أقرب إلى الموجة الجيبية.

وقد تم توليد فولتية جيبية متناوبة من مصدر مستمر باستخدام تقنية المغيرات متعددة المستوى مربوطة على التوالي، هذه التقنية تنتج أقل قيمة للتوافقيات في الإشارة الخارجة المتناوبة وبالتالي تقلل من استخدام المرشحات. التردد المستخدم في هذه الدائرة هو 50 هرتز. تم تطبيق هذه الدائرة عملياً على الموجات المتدرجة ذات التقاطع اللاصفرى (3،5،7) وقد تمت محاكاة الدائرة باستخدام برنامج (Matlab) . أن عامل التشويه التوافق يتناقص بمقدار 23.29% للموجات المتتابعة للتقاطع الصفري 22.29% للموجات المتتابعة للتقاطع اللاصفرى. تم الحصول على أقل عامل تشويه كلي في حالة الموجة المتدرجة السابعة حيث كانت قيمه عامل التشويه (0.0263) . النتائج التي تم الحصول عليها بينت أن الدائرة المقدمة أعطت نتائج متطابقة مع المعادلات الرياضية النظرية .

#### **I. INTRODUCTION**

The dc-to-ac converters are known as inverters. The function of inverter is to change a dc input voltage to a symmetrical ac output voltage of desired magnitude and frequency. The output voltage waveform for an ideal inverter should be sinusoidal. However, the waveforms of the practical inverters are non sinusoidal and contain harmonics. For low – and medium-power applications, square-wave or quasi- square-wave voltages may be acceptable but for high power applications, low distorted sinusoidal waveforms are required. With the availability of high- speed power

semiconductor devices, the harmonic contents of output voltage can be minimized or reduced significantly by switching techniques. (Dewan, 1975)<sup>[1]</sup> and (Williams, 1987)<sup>[2]</sup>.

Inverters are widely used in industrial applications e.g. variable –speed ac motor drives induction heating, and standby power supply. The input of the inverter may be a battery, fuel cell, solar cell, or other dc sources. The dc-ac inverter supplies the alternating output in two ways mainly, a stepped transition of voltage between the positive and negative voltage levels (known as modified square wave output inverters) or those that more smoothly alter the voltage between the two polarities(known as sinewave output inverters) which more accurately reflect the normal household supply.

The choice between the two types will depend on the nature of the applications which are to be used. (Matsui et al, 2000) <sup>[3]</sup>.

A new type of inverter, the multilevel voltage source inverter, has become popular in high voltage and high power applications. Multilevel inverters synthesize the ac voltage from several different levels of dc voltages. Each additional dc voltage level adds a step to the ac voltage waveform. For this reason, multilevel inverters can easily provide the high power required of a large electric drive. For example, cascaded H-bridges can be used to drive the traction motor from several separate dc source. A staircase waveform can be approximated to sinusoidal waveform with minimum harmonic distortion .(Tolbert and Peng, 2000) <sup>[4]</sup>and (Tolbert et al ,2000)<sup>[5]</sup>

The output voltage waveform of multilevel inverter is composed of a number of voltage levels starting from three levels and reaching infinity depending upon the number of the dc source. The m-level inverter consists of at least one phase wherein each phase has a full-bridge inverters with an independent dc source.(Tolbert et al,1999)<sup>[6]</sup>and (Lee.et al,2002) <sup>[7]</sup>

The multilevel voltage source inverter has been recently applied in many industrial applications such as power supply, FACTS , drive system, medium voltage adjustable speed motor drives , and harmonic filtering.(Menzies at al, 1994) <sup>[8]</sup>.

One of the biggest problems in power quality is the harmonic contents in the electrical system. Generally, harmonics may be divided into two types : 1) voltage harmonics, and 2) current harmonics. Current harmonics is usually generated by harmonics contained in voltage supply and depends on the type of load such as resistive load, capacitive load, and inductive load. Both harmonics can be generated by either the source or the load side. Harmonics generated by load are caused by nonlinear operation of devices, including power converters, arc-furnaces, gas discharge lighting devices...etc. Load harmonics can cause the overheating of the magnetic cores of transformer and motors. (Chiasson at al , 2003) <sup>[9]</sup>

## **II. CASCADED H-BRIDGE**

Cascade multilevel inverter consists of a series of H-bridge (single-phase Full-bridge) inverter units as shown in Fig. (1). The function of this multilevel inverter is to synthesize a desired voltage from several separate dc sources, which may be obtained from batteries, fuel cell, or ultra-capacitors in HEV.( J. Chiasson at al, 2002) <sup>[10]</sup>

Each separated dc source is connected to a single-phase full-bridge inverter. Each inverter level can generate three different voltage outputs  $+V_{dc}$  , 0,  $-V_{dc}$  by connecting the dc source to the ac output side by different combination of the four switches,  $S_{a1}$ ,  $S_{a2}$ ,  $S_{a3}$  and  $S_{a4}$  . The ac output of different level of full-bridge inverters are connected in series such that the synthesized voltage waveform is the sum of all of the individual inverter outputs .(Bhagwat and Stefanovic ,1983) <sup>[11]</sup>.

The number of output phase voltage levels is defined in a different way from those of two previous inverters. In this topology, the number of output phase voltage level is defined by :

$$m=2S+1 \dots\dots\dots (1)$$

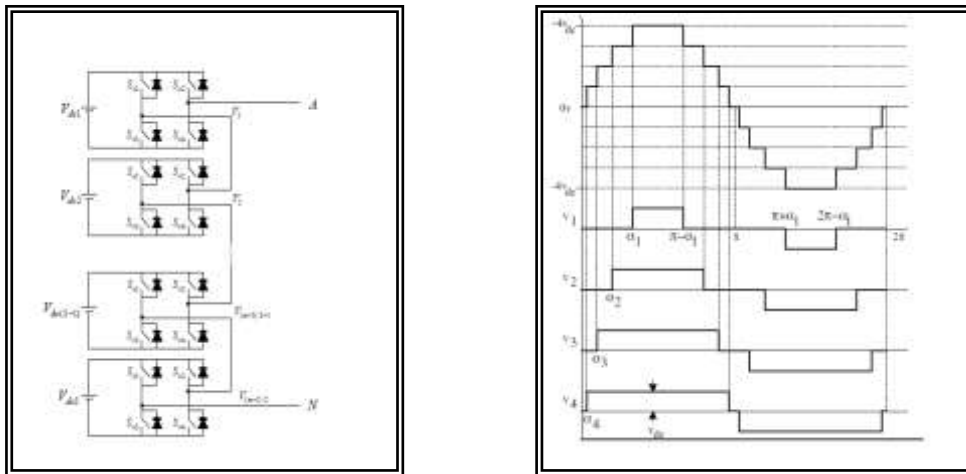
Where S=The number of DC source

m=The number of output phase voltage levels

The phase voltage is the sum of each H-bridge output which is given by:-

$$V_{AN} = V_1 + V_2 + V_3 + \dots + V_{s-1} + V_s \quad \dots \dots \dots (2)$$

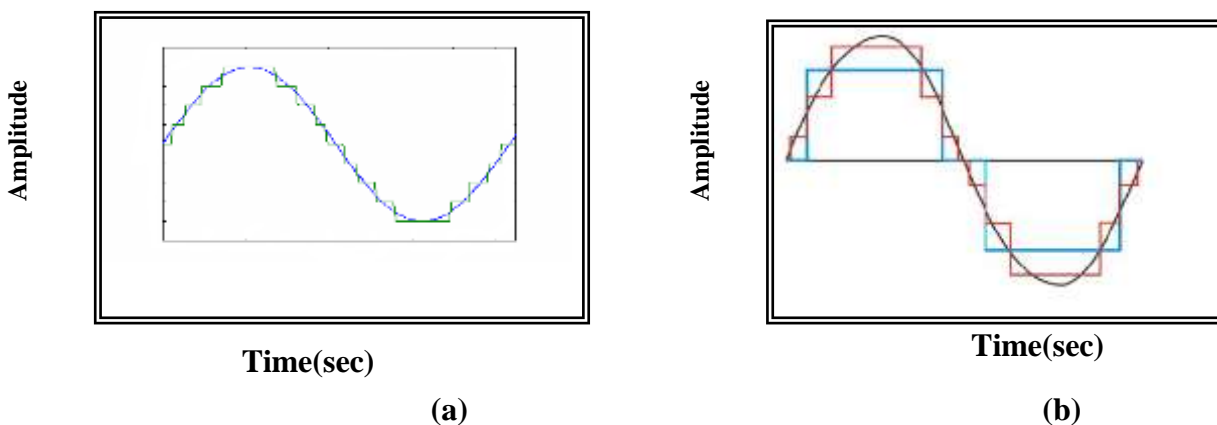
Where  $V_{AN}$  = The phase voltage



**Fig. (1) : (a)Single- phase structure of a m-level cascaded inverter. (b) Output Voltage Waveform of the H-bridge Cell series-connected Cascaded Multilevel Inverter**

In this work, the generation of stepped sinewave has been investigated theoretically which represents the main part of the stepped sinewave dc-ac inverter. Two types of stepped sinewave generation were used as maintained below:  
 a- Zero crossing, and b- Nonzero crossing.

The first one indicates that one of the steps lays on the x-axis, while the second one indicates that all steps are up or down the x-axis, as shown in figures 2(a & b). The effect of the switching angle with different number of steps on the generated voltage and total harmonic distortion has been analyzed in the two cases using "Matlab" Software.



**Fig. (2). (a)Zero crossing stepped sinewave (b) Nonzero crossing stepped sinewave**

**III. Harmonic Analysis of Stepped-Sinewave:**

Stepped-sinewave can be generated by the summation of different square waves with different magnitudes and phase shift. The magnitude of each square wave can be determined as:

(Ashour.2005) <sup>[12]</sup>

$$E_1 = V_1 \dots\dots\dots (3)$$

$$E_2 = (V_2 - V_1) \dots\dots\dots (4)$$

$$E_k = (V_k - V_{k-1}) \dots\dots\dots (5)$$

Where

$$V_1 = V_{\max} \sin [180/2N] \dots\dots\dots (6)$$

$$V_k = V_{\max} \sin [(180*(2k-1))/2N] \dots\dots\dots (7)$$

The phase shift of each square wave can be determined as:

$$\theta_n = (180*(k-1)) / N \dots\dots\dots (8)$$

$$THD = \frac{\sqrt{\sum_3^{\infty} (a_n)^2}}{a_1} \dots\dots\dots (9)$$

Where:

$a_1$  = rms of the fundamental component

$a_n$  = The rms value of the n harmonic

S = number of source

n = Degree of harmonics

V=Output voltage level

N=the number of steps

E= Amplitude of DC supply

K=Varies from 2 to N

$\theta$ = Degree of switching angle

Equations (1) to (8) are solved to get the values of switching angle  $\theta_1, \theta_2, \dots, \theta_s$  and amplitude of the dc supply for different steps which gives minimum total harmonic distortion. The results are listed in Table (1).

<i>Switching angle (Degree)</i>	<i>Amplitude of DC supply (Volte)</i>	<i>Number of steps</i>
---------------------------------	---------------------------------------	------------------------

**Table (1):Switching angle and amplitude of DC for three, five, and seven steps**

$\theta=120$	$E3=0$	
$\theta=0$	$E1=96$	
$\theta=36$	$E2=156$	5
$\theta=72$	$E3=60$	
$\theta=25$	$E1=195$	
$\theta=51$	$E2=69$	7
$\theta=77$	$E3=48$	

#### IV The Proposed Program of Cascaded Inverter

In this work a simulation program using "Matlab" software has been carried out to get the total harmonic distortion total harmonic distortion for different steps in two types nonzero crossing and zero crossing, where the total harmonic distortion is used to indicate the quantity of harmonics contents in the out put waveforms.

This work focuses on two techniques to reduce the total harmonic distortion, the first one is in the switching angle, the second is in the amplitude of steps.

The effect of switching angle with different number of steps has been analyzed using "Developer Fortran" program.

Table (2) summarizes the total harmonic distortion and the switching angle at different number of steps. It may be observed that as the number of steps are increases, the total harmonic distortion decreases.

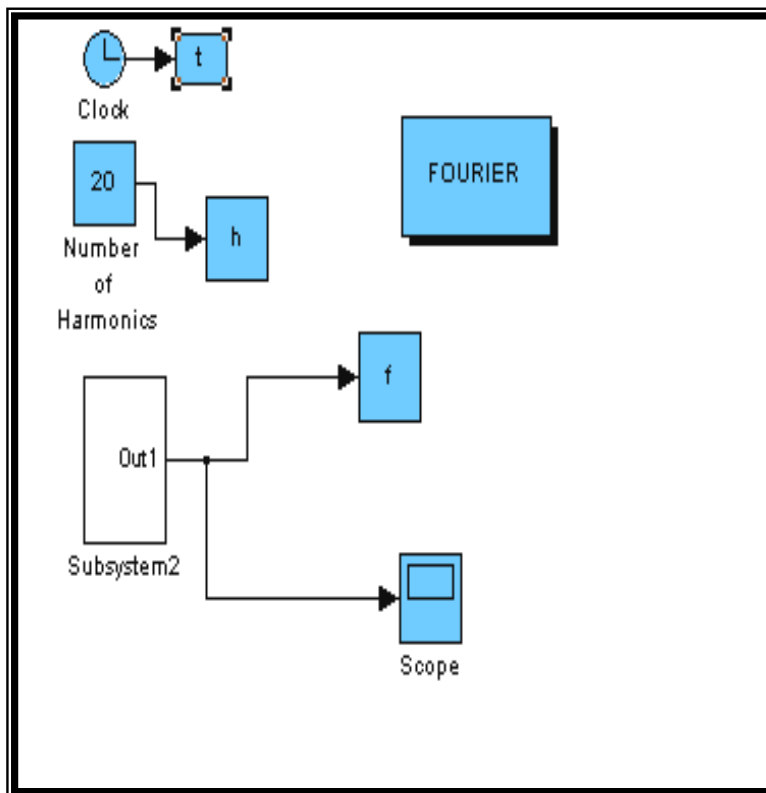
The second technique is realized by playing in the Y-axis on the zero crossing and non zero crossing by using "Matlab" software. From this analysis it can be seen that the sine waveform can be generated as a result of the summation of different square waves, and the increasing number of the square wave steps will reduce the total harmonic distortion of the resultant generated wave. The simulation diagram for simulating the steps (3 ,5 ,7 ,9, and 11) is shown in Fig. (3). The generating of stepped waves with the frequency spectrum for the zero and nonzero crossing steps is shown in Figs. (4) to (9) respectively for different steps.

The total harmonic distortion and different number of steps in zero and non zero crossing are listed in Table (3). The simulated results by using "Matlab" are shown in Fig. (10). It can be seen from the Table(3) that the total harmonic distortion decreases as the number of steps increases for both zero and nonzero crossing stepped sinewave . Total harmonic distortion is decreased by 23.29% for zero crossing if the number of steps 11 with respect to 3 steps and total harmonic distortion is decreased by 22.29% for non zero crossing stepped if the number of steps 11 with respect to 3 steps. The simulated result from the comparison between the zero and nonzero shows

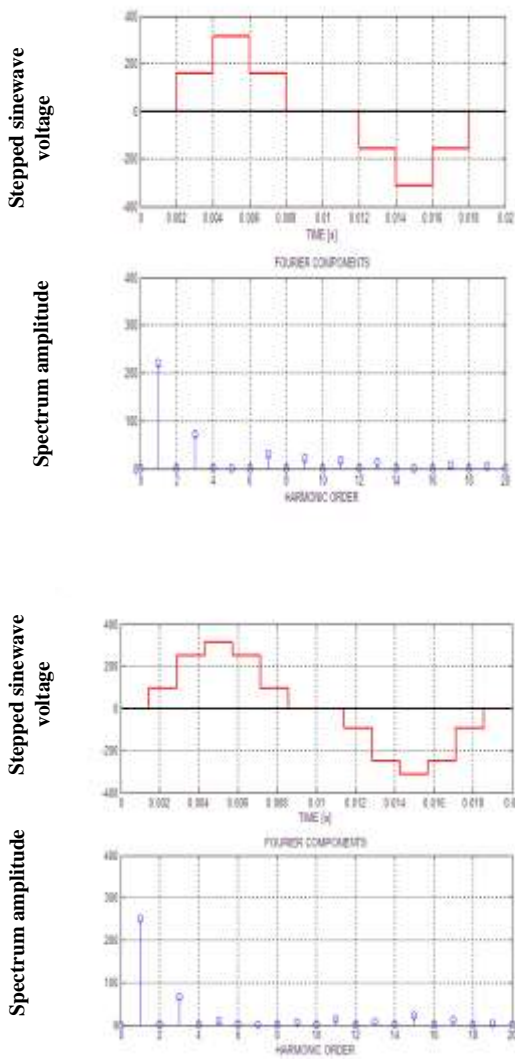
that the total harmonic distortion in nonzero crossing is less than the zero crossing stepped sinewave.

**Table (2): Total harmonic distortion and number of sweching angls**

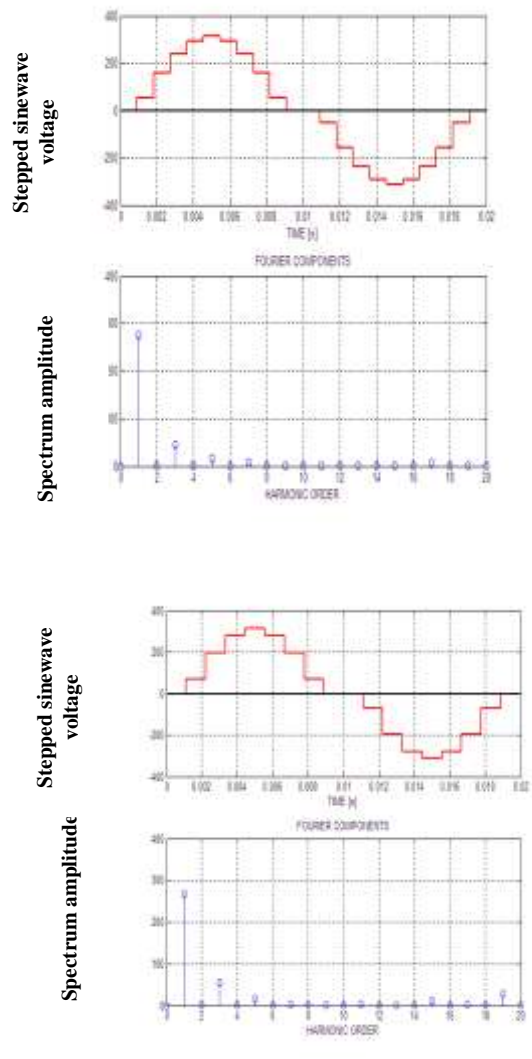
<i>No of switching Angles</i>	<i>THD%</i>
3	11.5
5	6.1
7	4.9



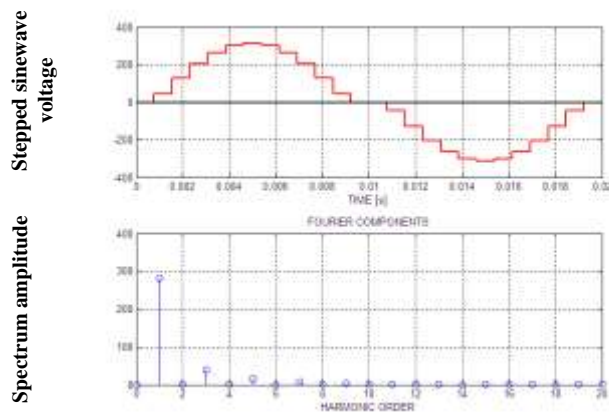
**Fig(3):Simulated diagram for stepped sinewave signal**



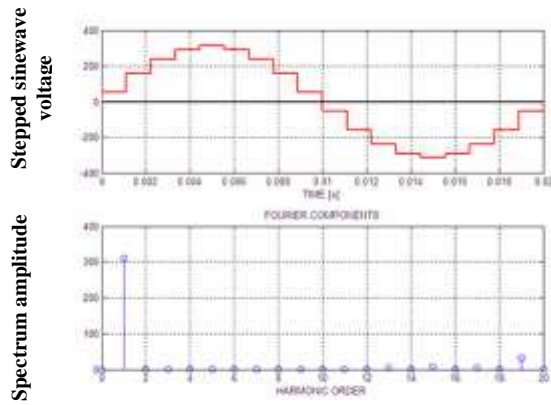
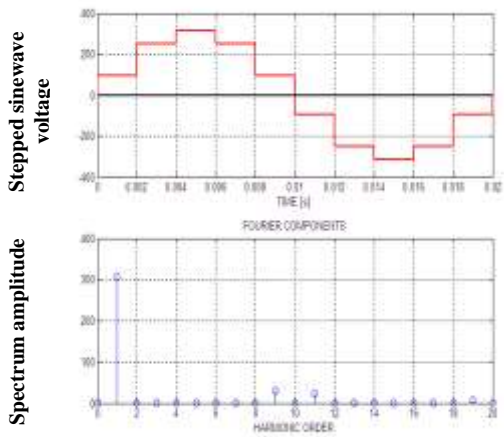
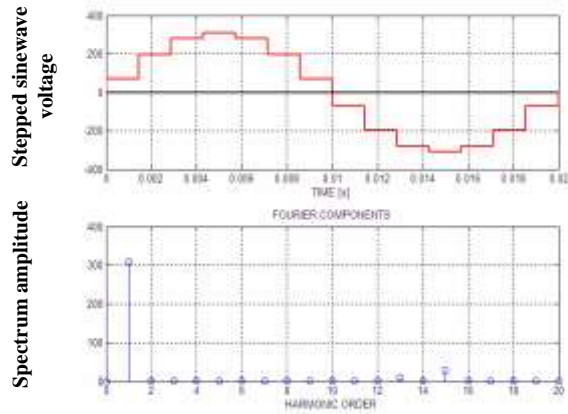
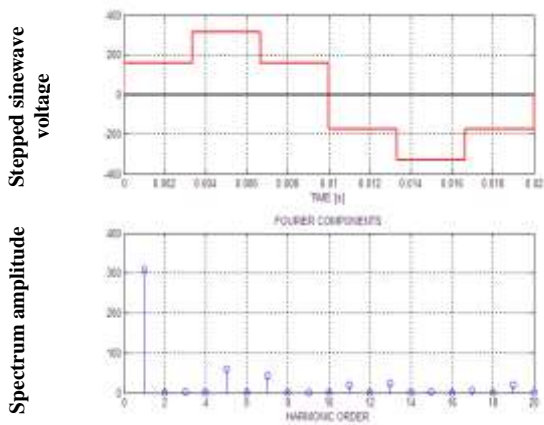
**Fig (4):The spectrum analysis of three and five steps zero crossing sine wave signal**



**Fig (5): The spectrum analysis of seven and nine steps zero crossing sine wave signal**

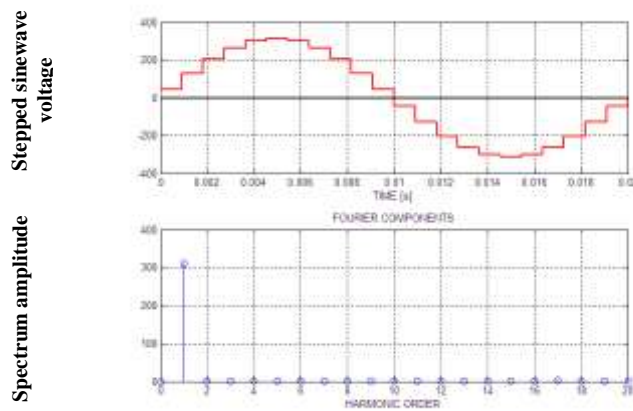


**Fig (6):The spectrum analysis of Eleven Steps zero crossing sine wave**



**Fig(7):The Spectrum analysis of three and five nonzero stepped sine wave signal**

**Fig (8):The spectrum analysis of seven and nine Steps non zero crossing sine wave**

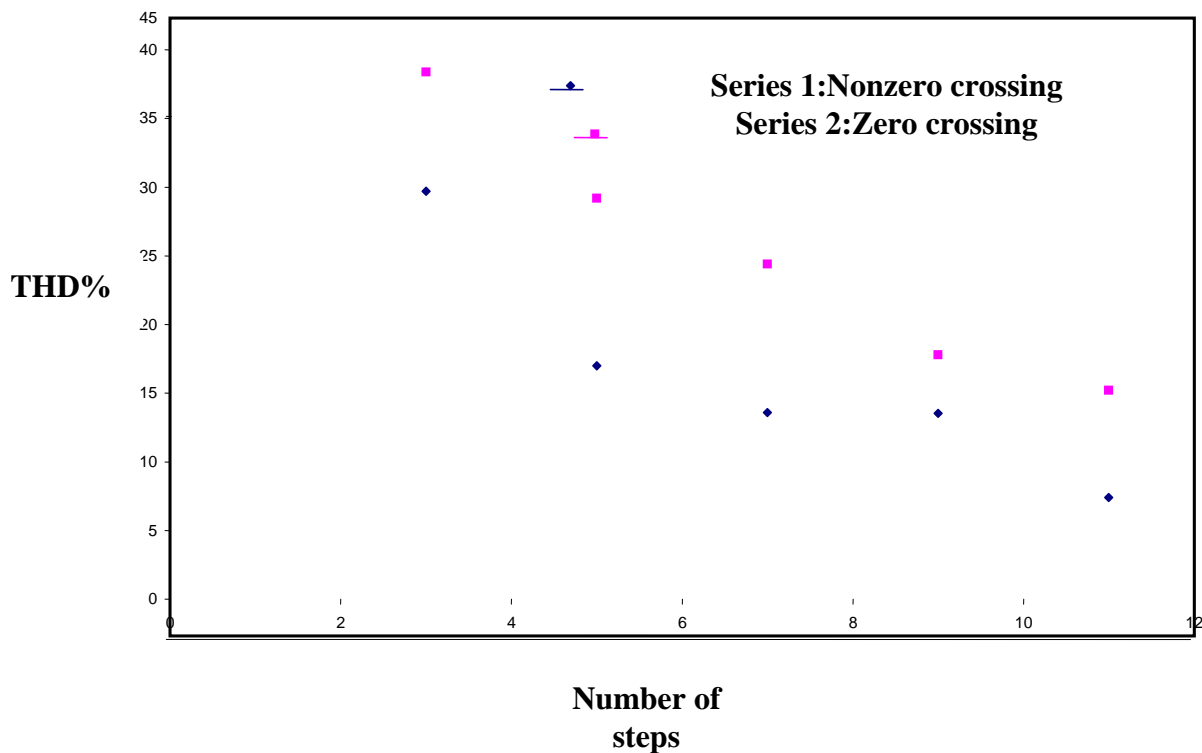


**Fig (9):The spectrum analysis of eleven Steps non zero crossing sine wave**



**Table (3): Comparison between zero and non zero crossing in stepped sine wave**

<i>No of steps</i>	<i>THD% in non zero crossing</i>	<i>THD% in zero crossing</i>
3	29.7	38.4
5	17	29.2
7	13.58	24.4
9	13.52	17.8
11	7.41	15.2



**Fig(10): Comparison between zero crossing and nonzero crossing stepped signal with THD%**

## **Conclusion**

From the above study it can be concluded that the effect of number of steps on the generated voltage has been analyzed and the total harmonic distortion (THD) is decreased by 23.29% for zero crossing stepped and by 22.29% for non-zero crossing stepped.

## **References**

- [1] Dewan .S. B, (1975) ; "Power semiconductor circuit,"John.Wiley and Sons. Inc,
- [2] Williams .B. W,(1987); "Power electronics devices, drivers and applications,"Macmillan Education LID.
- [3] Matsui .K , Kawata.Y , and Ueda .F,(2000);" Application of parallel connected NPC-PWM inverters with multilevel modulation for AC motor drive ", IEEE Transactions. on Power Electronics , Vol . 15 , No. 5 , pp.901-907 .
- [4] Tolbert. L. M. and Peng. F.Z. ,(2000); "Multilevel Converters as a Utility Interface for Renewable Energy Systems, " in Proc. IEEE Power Eng. Soc. Summer Meeting, Seattle,PP.1271-1274.
- [5] Tolbert. L .M.and Habetler T. G,(1999);"Novel Multilevel Inverter Carrier-based PWM Methods,"IEEE Transactions on Industry Applications,Vol. 35, No.5, pp 1098-1107.
- [6] Tolbert. L. M, Peng. F. Z, and Habetler T. G. 1999;"Multilevel Converter for Larg-Electric Drives," IEEE Transactions on Industry Applications,Vol.35,No.1, pp. 36-44.
- [7] Lee. C .K , Hui. S . Y. R and Chung H .S .H, 2002;" A31 –Level Cascade Inverter for Power Applications " , IEEE Transactions on Industrial Electronics , Vol .49 ,No 3, pp. 613 -617 .
- [8] Menzies. W, Steiner. P , Steinke. J. K ,1994; " Five –level GTO Inverter for Large Induction Motor Drive ,"IEEE Transations on Industry Applications, Vol . 30, No . 4, pp. 938 -944 .
- [9] Chiasson. J, Tolbert. L. M, Mckenzie. K, Du. Z, 2003; "Harmonic Elementation in Multilevel Inverters," to appear in the proceedings of IASTED .
- [10] Chiasson. J, Tolbert. L.M, Mckenzie. K and Du. Z, 2002; "Eliminating Harmonics in a Multilevel Inverter Using Resultant Theory," in Proc. IEEE Power Electron.Sept.Conf.,Cairns,A ustralia, pp. 503-508.
- [11] Bhagwat P.M. and . Stefanovic V.R, 1983;"Generalized Structure of a Multilevel PWM Inverter, "IEEE Transactions on Industry Applications, Vol.IA-19,No.6,pp.1057-1069.
- [12] Ashour. H ;(2005) "Stepped SineWave Supply For Power Application" Arab Academy for Science and Technology,Egept

**LIST OF ABBREVIATIONS**

<b>SYMBOL</b>	<b>DESCRIPTION</b>
THD	Total Harmonic Distortion
OHSW	Optimising Harmonic Stepped Sinewave