

Design device to measure the speed of objects

Khawla J.Tahir alaa mohammed
College of Science, Karbala University, Iraq.

Abstract

Speed measurements are very important in many applications, Speed objects measuring device measure the quicken moving objects by using two lasers transit with 60 cm distance and give the time of objects passing through the two lasers and then calculate the speed by use the equation(3), wide diffusion in very different fields is due not only to the high sensitivity and reliability of laser techniques, but also to availability expenditure optical components, high quality and low-cost laser. Laser sources have been already successfully applied.

الخلاصة

ان قياس سرعة الاجسام مهمة جدا في العديد من التطبيقات ، وتم قياس سرعة الاجسام المتحركة عن طريق استخدام جهاز الليزر مع مسافة 60 سم بين الشعاعين وتسجيل الوقت من الاجسام التي تمر من خلال اشعة الليزر الاول والثاني ثم حساب السرعة عن طريق استخدام المعادلة الخاصه بذلك ، وان هذا التطبيق انتشر بصورة واسعة في مختلف المجالات ويرجع ذلك ليس فقط للحساسية العالية ودقة تقنيات الليزر ، ولكن أيضا لتوافر النفقات المكونات البصرية ، والجودة العالية لليزر منخفض التكلفة.

Introduction

In selective manual speed measurements with laser equipment, the test personnel perform the measurement by hand or using a tripod. As the stationary case was with supervised radar measurements the duration, frequency and location of such speed checks depend on the accident rate and the risk evaluation by the police. This measurement technique is suited above all to speed measurements on motorcycles but also other vehicles over greater distances. The measurement takes one half of a second at most. This means that warning devices possibly used by drivers generally respond too late The measurement station can be combined with a traffic stop so the affected drivers can be immediately informed of their incorrect behavior [1]. One way to determine the distance to an object is to measure time taken for a short pulse of laser radiation to reach the object and reflect back to the observer .because of its similarity to the radar technique employing ratio –frequency waves. This method is known as optical radar or lidar (light detection and ranging), When the laser beam is used for a radar application, it is called lidar. The details, which could not be achieved earlier with microwave radars, can now be obtained with lidar. Besides, the laser beam can be focused with lenses an mirrors easily whereas microwaves need huge antenna for focusing. As a beacon or a radar, the advantages of utilizing small antenna and components are obvious. With a lidar, the dimension and the distance of the target can be obtained with higher accuracy, which is not possible with the conventional microwave radar. The lasers used in lidars are of carbon dioxide, He-Ne laser, or gallium arsenide semiconductor type. The great advantage of the use of carbon dioxide lasers for radar application is their capacity to produce high power output with requisite The spectral purity. The coherent carbon dioxide laser tips radar functions essential like a coherent microwave radar except for the fact that the carbon dioxide laser beam has a frequency of a few thousand times more than that of the X-band radar and at it a sharp beam width of a few micro radians. The high frequency of the carbon dioxide laser also produces high Doppler shift even from slow-moving targets. The fine beam width and high Doppler the shift give the carbon dioxide laser an unparalleled imaging capability. This radar system is used for and measuring radial velocities to track low-flying aircraft and slow-moving objects. Since the laser beam is very much attenuated

by rain, fog, or snow, the lidar can perform well only in good weather conditions.[2]

Laser may be used to measure velocities by taking advantage of the Doppler effect .the basic idea is the same as that used in radar- equipped police car. Laser Doppler velocity measurement is a well established method for measuring the velocity of the moving target. The method is based on the laser Doppler effect due to the moving of the target, and has been used in a variety of fields.[3–4] The traditional homodyne velocimeter using a single-frequency laser has the problem of frequency dc drift due to its measurement principle, and is sensitive to the measurement environment. Therefore, the application of homodyne velocimeter is limited. The laser heterodyne velocimeter is superior to the homodyne velocimeter for high signal-to-noise ratio with no frequency dc drift. However, the maximum measurable velocity of traditional heterodyne velocimeter is lower, which depends on the frequency difference between the two frequencies of the laser.[5] In order to meet the demands for the velocity measurement of the high-velocity, Doppler effect (or Doppler shift), is defined as the phenomena when frequency of a wave changes and an observer moves relative to its source. When the wave travels in a medium, the velocity of the observer and of the source is determined, considering motion of the medium in which waves travel [6].

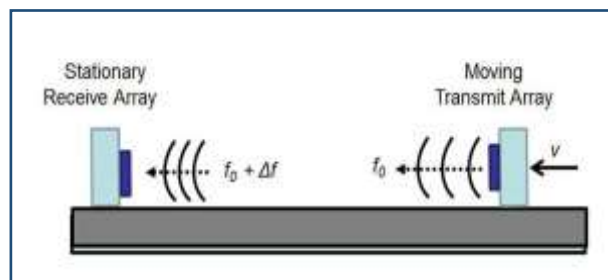

Fig. 1 Change of frequency by a moving source

When the velocity of waves (≈ 343 m/s) in the medium is much faster than the velocity of the source and of the receiver relative to the medium, the equation between receiver-observed frequency f and transmitter-emitted frequency f_0 is given by[7]

$$\frac{f - f_0}{f_0} = \frac{v_s}{c} \dots\dots\dots(1)$$

Where, v_s is the velocity of the moving target, C is the speed of sound. If the source and transmitter both move with respect to a stationary reflector and stationary medium, then[7]

$$\frac{f - f_0}{f_0} = \frac{2v_s}{c} \dots\dots\dots(2)$$

The most important application is Doppler RADAR. The Doppler RADAR is used for the measurement of a target velocity using Doppler shift. A microwave is used for the Doppler RADAR and the velocity is determined by analyzing the Doppler shift. Early versions of the Doppler RADAR were continuous wave (CW) and frequency modulated CW (FMCW). Recently, pulse-Doppler RADAR (PD) and Doppler processors for coherent pulse RADARs were developed. The use of both Doppler processing and pulse RADARs detects velocity of a target more accurately[7]

Comparison between the characteristics of the radar and Lidar

Advantages of Radar

Very flexible - can be used in a number of ways, Stationary mode , Moving mode, Two Directional mode, Beam spread can incorporate many targets, Can often select fastest target, or best reflection and Still very reliable

Radar Disadvantages

Time - Radar can take up to 2 seconds to lock on, Radar has wide beam spread (50 ft diameter over 200 ft range), Cannot track if deceleration is greater than one mph/second, Large targets close to radar can saturate receiver, Hand-held modulation can falsify readings and More interference sources[8]

Lidar Advantages

Faster lock-on time (less than 1/3 second), Very narrow beam spread (less than 6 ft over 2000 ft range), Better ability to track decelerating targets, Typically mounted, and aimed with optical targeting device, Fewer sources of interference and Much more difficult to detect, but some Problems with Lidar

Particles (dust, water) in air can limit range, Rounded surfaces, the colors black, blue, and violet are poor reflectors, Can be difficult to track target, Alignment can cause severe error and Extreme sunlight can be damaging[9]

Lidar System Components

In general, a lidar system consists of three main components: the transmitter, the receiver and the detector. A simple block diagram of these basic components is shown below in Figure 2.

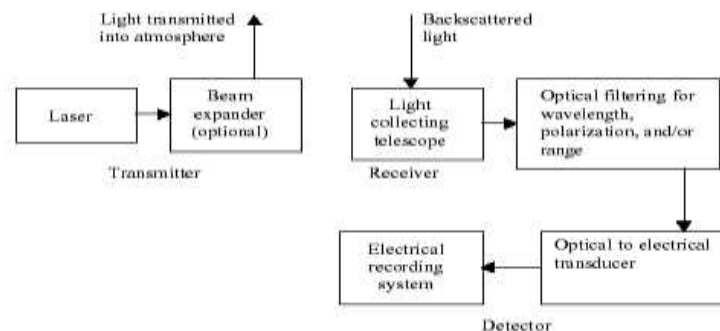

Figure 2: Block Diagram of a Generic Lidar System [10]

1. Lidar Transmitter

The transmitter includes the laser that is used to generate a continuous or pulsed laser beam at a variety of wavelengths ranging from the infrared through the visible and into the ultraviolet. The wide variety of wavelengths that are used in lidar systems gives it a capacity to measure a number of atmospheric variables. Many systems also incorporate a beam expander in the transmitter module that can help reduce the beam divergence and increase the beam diameter, which in turn diminishes unwanted background return scatter that can add noise to the return signal. This beam expander typically comes in the form of a convex lens. Also, a portion of the laser beam is sampled and used as a reference to which the backscatter signals can be compared [10].

2. Lidar Receiver

In the receiver, a telescope collects the photons that are scattered by the body that is being measured and directs them to a photo detector that converts the light into an electrical signal. The size of the telescope plays an important role in the accuracy of the lidar since the strength of the electrical signal depends on the amount of light that can be collected by the telescope. Naturally, the larger the optical telescope, the larger proportion of photons that can be detected after scattering. The diameter of most lidar telescopes range from approximately 10 cm to a few meters [10]. Smaller telescope diameters can be used when lower heights (less than 150 m) are being probed because the intensity of light that is returned at these heights is more substantial. However, the focal ratio of the telescope can cause uncertainty in range-resolved measurements.

3. Lidar Detector

The detector is the system component that records the intensity of the light that is collected by the receiver. The detector in various lidar systems can record information about the return signal by using either a photon counting method, analog signal detection or coherent detection method. While each method has its advantages, coherent detection is most commonly used for wind velocity measurements. Coherent detection allows the frequency shift of the return signal to be determined by a relatively straightforward method that isolates the difference between the frequency of emitted light and that of the backscattered light. Lidar systems that employ coherent detection tend to be cheaper and more robust because this method eliminates several sensitive and costly components that are associated with photon counting[10].

flip-flop

The characteristic table of the set/reset (SR) flip-flop is shown in Fig. 2 . If $S=R=0$, the flip-flop remains at its previous state; if $S=1$ $R=0$, it is set to “state 1”; if $S=0$ $R=1$, it is set to “state 0”. $S=R=1$

is forbidden since the flip-flop is unstable in this case. The setup of clocked SR flip-flop is shown in Fig. 3 (a): it consists of two AND gates and one SR latch. “AND 1” and “AND 2” perform AND function between the clock pulse and S and R, respectively. The outputs of “AND 1” and “AND 2” are connected to the “Set” and “Reset” ports of the latch respectively. The operation principle of this clocked flip-flop is shown in Fig. 3 (b): when a clock pulse comes, if $S=R=0$ it can not pass through either “AND 1” or “AND 2”, so “Set” and “Reset” ports receive no pulse and the latch maintains its previous state ($Q_{Next}=Q$); if $S=1$ $R=0$, the clock pulse can pass through “AND 1” but is blocked by “AND 2”, so only “Set” receives a pulse and the latch is set to “state 1” ($Q_{Next}=1$); if $S=0$ $R=1$, the clock pulse can pass through “AND 2” but is blocked by “AND 1”, so the latch is set to “state 0” ($Q_{Next}=0$). $S=R=1$ is forbidden since the latch is unstable when “Set” and “Reset” receive pulses simultaneously. The flip-flop is clocked because it only changes state when a clock pulse comes, according to the S and R values at that time. S and R values at any other time are ignored.[11-12].



Fig. 3 Clocked SR flip-flop: (a) logic circuits; (b) working principle.

Experiment

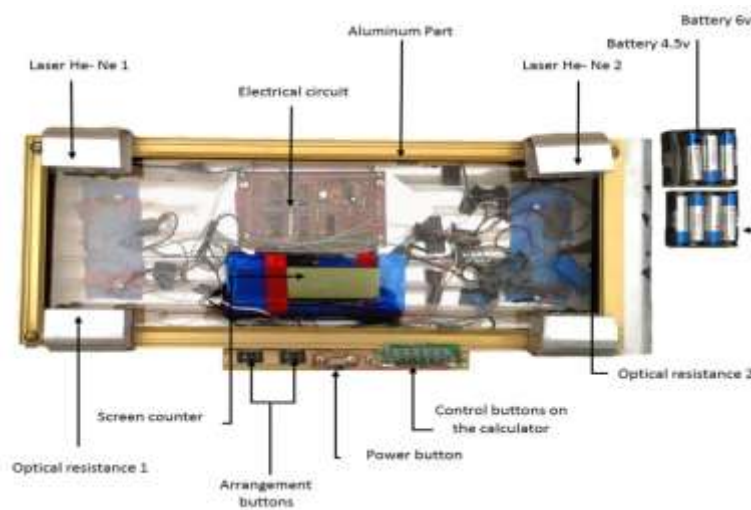

Figure 4 - The top section of the device.

When the object crossing through the first laser , electronic circuit begin to counting until the object reaches to the second laser then the counting go to stop and by holds count we can calculate the time of the object Which cross Between two lasers and the speed calculated by the equation.

$$v = \frac{m}{t} \dots\dots\dots(3)$$

Where v is object velocity- m is fixed distance between the two lasers and t is Time, which is measured by circuit.

Elements necessary for device

1. Laser He- Ne (two)
2. Optical resistance (two)
3. Electronic circuit
4. Power source (6V & 4.5V) dc
5. Calculator

lasers He- Ne

It working with 4.5 V and give us the field about 633 nm.

optical resistance :

Optical resistance (Light Dependent Resistor) Symbolized by the short LDR is resistant light-sensitive electric Covering an insulating material such as ceramic with a thin layer of semiconductor material Sensitive to light. Resistors consist of the layer of optical silent Light at 600 - 730 nm.



Fig. 5 Optical resistance

electronic circuit :

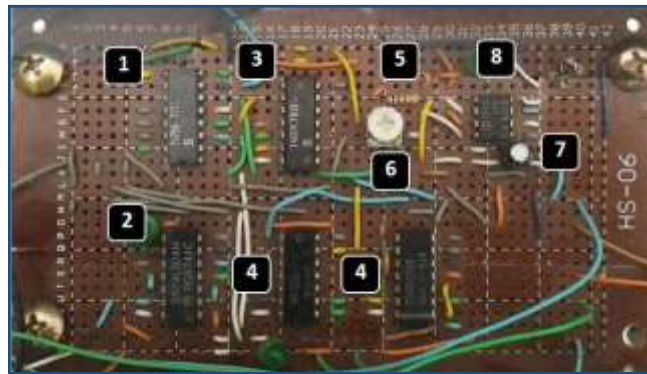
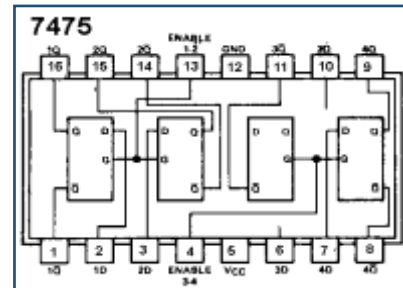

Fig. 6 electronic circuit

This electrical circuit is the base of the devices work electronic circuit It consists of

1. IC 7475

Contain four gates of the flip flop type and this gate make the fixed signal.



2. IC 7404

Contain six gates of the not type and this gate make the opposite signal.

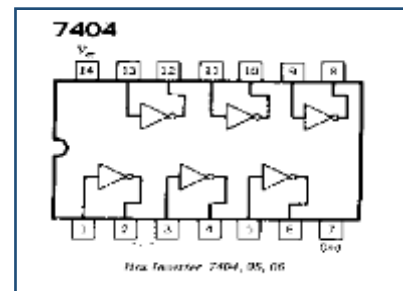

3. IC 7486

Contain four gates of the X-OR type, and its conditional gate which working in equal entrances.

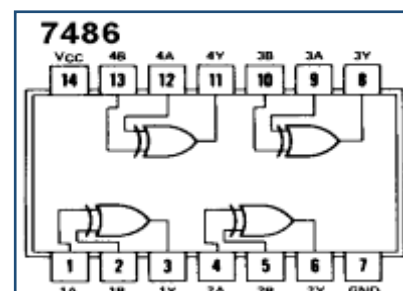

4. IC 7016
Contain four electronic switches.

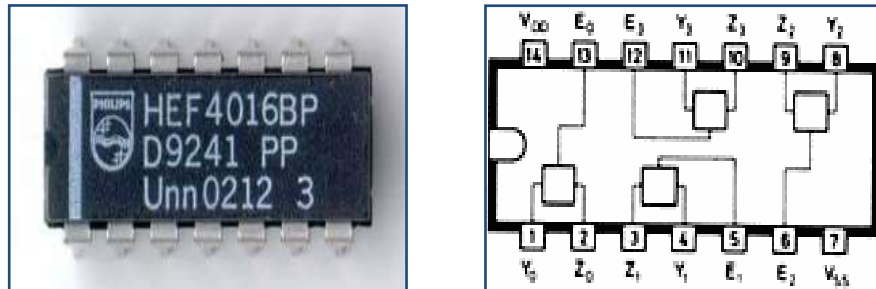

- 5. Resistance 7.5 kΩ
- 6. Variable resistance 100 KΩ
- 7. Capacity chemical 110 μf
- 8. IC 555

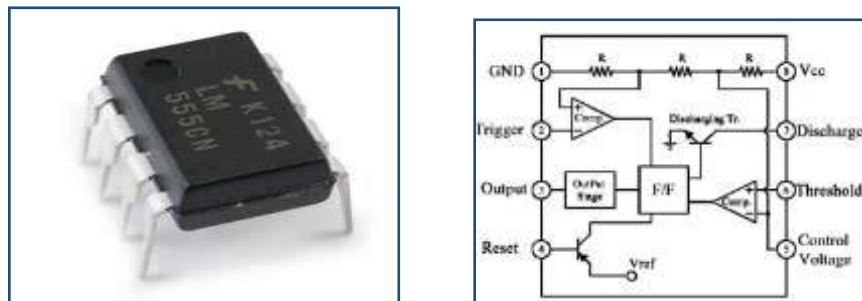

the IC 555 is a monolithic timing circuit that can produce accurate and highly stable time delays or oscillation. Like other commonly used op-amps, this IC is also very much reliable, easy to use and cheaper in cost. It has a variety of applications including mono stable and a stable multi vibrators, dc-dc converters, digital logic probes, waveform generators, analog frequency meters and tachometers, temperature measurement and control devices, voltage regulators etc.

Explain the work of circuit:

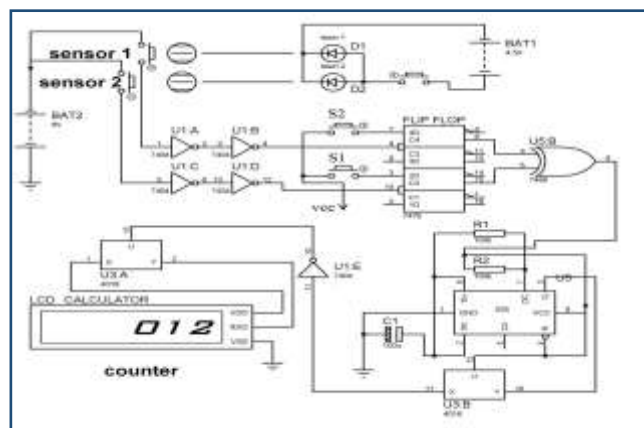

Fig. 7 Electronic circuit graph

After connecting the circuit as the Fig. 7., it Connecting by electric current, when both of two lasers first and second provisioning sensors (resistors light) by required light to give each sensor high voltage about 5v to the not gate and then enter into another not gate to make a low voltage about 0.1v , then both voltages enter into flip-flop gates ,properties of the flip-flop IC is that , the

9th entrance take the voltage of 7th entrance if the 4th entrance become high signal and 15th entrance take the voltage of 3th entrance if the 13th entrance Become High signal, so make both entrances 3 th and 7 th on the High signal by using switches S1 and S2.

Calculator used in this experience in exchange for counter and button equal of the calculator belted with the circuit. Now enter in the calculator zero plus one, properties of the calculator is adds one to the process whenever we pressed the equal button.

circuit is ready to measure , while crossing an object Through the first laser , the provisioning light of the first sensor go to stop , In this case resistance become rise and doesn't give any Electric current to make High voltage, So we get different voltages low and high , both of these voltages enter into the XOR gate, properties of the XOR gate is that ,the output voltage is in law style when the both inputs are same and give high voltage when the one of those become in disagreement with another .The output voltage go to IC555, the IC 555 is in a sub circuit called timer of which create intermittent pulses and its depends at the resistance changing R1 reach to 1000 pulses per second,

In this case each pulse interference in ic 4016 (the switches ic), the one of switch gate reach to the two parties of the equal Button of calculator, in order click the equal button by 1000 times per second get a count, this process will continue until the object arrival to second laser and configure other pulse equal first voltage entering to the Flip flop gate, and then the circle will be stop Because inputs of xor gate are in same voltages. To calculation the time we should divide count number to 1000. Distance between two lasers is 1 meter; for example, if the count in the calculator was 100 after divide it to time. Time $100 / 1000 = 0.1s$ and dividing the distance to time $1 / 0.1$ we get 10 meters per second, speed of the object.

Result and discussion

the distance between two lasers is (60 cm) and speed count is 12 several in the second, other words the less time for the account is 83 msec. it means the maximum speed can be measured when the Circle give us number 1 to the calculator, the speed value become 13 kilometers per hour and the maximum speed you can be measured by this device. And these some Practical results

Table 1. The Values of velocities developments of the counter values

Counter value (n)	Objects speed (m/s)
25	0.288
15	0.48
6	1.2
4	1.8
2	3.6
1	7.2

of the table 1. you can see that the inverse relationship is between counter value and objects speed. The possible application of this device to used for general ways to measure Quicken vehicles, to connecting with the computer to control the violation vehicles, in the laboratories and specializations of scientific and in the sport tests and fitness.

Conclusion

In this paper Laser was applied to velocity measurement is a well established method for measuring the velocity of the moving target properties of the Cheap device , Quick Account, easy to make , High resolution, Safety and useful, Small size and light weight . Possible Development the device by increasing the distance between two lasers, for example, if distance become 6 meters the device give us a good accuracy up to ten times. Then measure velocity up to 130 kilometers per hour, Simple calculator can be changed with a kind of Micro Control counter until several counted 700,000 in the second and give reach time to $1.24 \mu s$, then device can calculate velocity up to

1,700,000 kilometers per hour and we Can increase the sensitivity of the measurement through the development of laser mirrors as in Fig. 8. Then the ability of the device become stronger and the device can senses small objects passing through it. We can use a computer for calculate quickly and give us a speed.



Fig. 8 lasers with mirrors

In the figure 8 you can see tow rectangular mirrors stand face to face to each other for reflation the path of the laser such as zigzag path to make Increase the possible of object Crossing of that.

Reference

1. www.metas.ch/verkehrsmesstechnik.
2. M. Boquet, P. Callard, N.Deve and E.G. Osler, "Return on Investment of a Lidar Remote Sensing Device", DEWI Magazin No. 37, pp. 56-61, August 2010.
3. Byun G, Olcmen S M and Simpson R L ,A miniature laser-Doppler velocimeter for simultaneous three-velocity-component measurements, Measure. Sci.Technol.,V.15,N.10,2004.
4. Li E B, Xi J, Chicharo JF, Yao J Q and Yu D Y, Multi-point laser Doppler velocimeter, Opt.Commun,V. 245,P. 309,2005.
5. Tian Q, Lowe KT and Simpson RL, A three-velocity-component laser-Doppler velocimeter for measurements inside the linear compressor cascade,Experments in Fluids, V. 43, p. 487,2007.
6. Maru K and Fujii Y , Wavelength-insensitive laser Doppler velocimeter using beam position shift induced by Mach-Zehnder interferometers ,Opt. Express,V.17,P. 17441,2009.
7. <http://members.aol.com/copradar/index.html>
8. www.fhwa.gov
9. Argall,P.S.and R.J.Sica,*Lidar*,in *Encyclopedia of Imaging Science and Technology*. 2002, Wiley.
10. D. Webster, "A pulsed ultrasonic distance measurement system based upon phase digitizing," Instrumentation and Measurement, IEEE Transactions on, vol. 43, pp. 578, 1994
11. M. Shin, "MRI Evaluation of a Stented Abdominal Aorta of a Rabbit." vol. MS: Univ of Alabama, Birmingham, 2007.
12. Wang, J.; Berrettini, G.; Meloni, G.; Potì, L.; Bogoni, A. All-Optical clocked D type flip-flop exploiting SOA-based optical SR latch and logic gates, accepted for publication at Photonics in Switching 2009, ThI 1-6, Pisa, Italy, (2009).