

Effect of Magnetic Field Distribution on the Performance of the Electromagnetic Flowmeter in Partially- Filled Pipes

Prof. Dr. S.E. Najem Dr. Qais A. Rashack Dr. Muncer A. Ismael
Mechanical Engineering Department- College of Engineering – University of Basrah

Electromagnetic flowmeters have proven their merit in measuring the flow rate of conducting liquids in fully-filled pipes. In contrast with the most of the published works about the electromagnetic flowmeter, the attentions were focused in this work into the use of these devices in partially-filled pipes. In this application these devices suffer from the problem of different outputs with different liquid level for the same flow rate. We studied whether the process of changing the distribution of the magnetic field through the measuring section improves the flowmeter performance against this drawback or not. An adaptive numerical mesh was used in predicting the flow induced signal and its response to the liquid level. The induced signal was assumed to be picked up by a pair of point electrodes tested for different angular positions.

The results showed that the performance of the electromagnetic flowmeter in partially-filled pipes could be appreciably improved by making the magnetic field progressively decreases from top to the bottom of the flowmeter. When the lower magnet coil is excited by a current one-half lower than the upper coil together with two point electrodes placed at 22° below the flowmeter horizontal centerline, the flowmeter performance offer more stable sensitivity.

تأثير توزيع المجال المغناطيسي على أداء مقياس الجريان الكهرومغناطيسي في الأنابيب الممتلئة جزئياً

أ.د. صالح اسماعيل نجم د.قيس عبد الحسن رشك د.مُنذر عبد الجليل اسماعيل
قسم الهندسة الميكانيكية - كلية الهندسة - جامعة البصرة

لقد أثبتت مقاييس الجريان الكهرومغناطيسية جدارتها في قياس معدل جريان الموائل الموصلة كهربائياً في الأنابيب الممتلئة كلياً. المشكلة المتأصلة في هذه الأجهزة هي تأثيرها بمنحنى توزيع السرعة للسائل المراد قياس معدل جريانه. أثبت باحثون كثيرون بأن تصميم و تشكيل مولد المجال المغناطيسي من أجل التغلب على هذه المشكلة لم يعط أي نتائج ذات قيمة عملية. تناولنا في هذا البحث جانباً غير مألوفاً في البحوث المنشورة حول مقياس الجريان الكهرومغناطيسي ، لقد درسنا أداء هذه الأجهزة في الأنابيب الممتلئة جزئياً. ركزنا في هذا البحث على معرفة فيما إذا كانت عملية تغيير توزيع كثافة المجال المغناطيسي داخل المقياس تحسن من أداء هذه الأجهزة أم لا في التطبيقات الممتلئة جزئياً. استخدمنا طريقة الحل العددي متكيف الشبكة من أجل حساب إشارة الجريان و مدى تأثيرها بمستوى السائل. افترضنا بأن الإشارة المحتثة تلتقط بواسطة لاقطات إشارة نقطية و لمواقع مختلفة على محيط المقياس. بينت النتائج بأن أداء هذه الأجهزة من الممكن أن يتحسن في حالة توليد مجال مغناطيسي متناقص تدريجياً من أعلى إلى أسفل مقطع القياس. لقد وجد بأن حساسية هذه الأجهزة تكون أكثر استقرارية عندما يكون التيار المار في ملف مولد المجال المغناطيسي الأسفل نصف قيمة التيار المار في الملف الأعلى على شرط أن يكون لاقطاً الإشارة مثبتان في موقع 22° أسفل خط المركز الأفقي للمقياس.

List of Symbols

A	Cross-sectional flow area	m^2
B	Uniform magnetic field	Tesla
\mathbf{B}	Magnetic field vector	Tesla
D	Flowmeter diameter	m
F	Magnetic field scalar potential	-
G	Virtual current scalar potential	-
h	Liquid level	m
\mathbf{j}_v	Virtual current density vector	$1/m^2$
I_l	Electric current passing through the lower coil	A
I_u	Electric current passing through the upper coil	A
l	Half magnet length	m
L	Half flowmeter length	m
S	Flowmeter sensitivity	-
V_m	Mean velocity	m/s
\mathbf{v}	Liquid velocity vector	m/s
\mathbf{W}	Weight vector	$V.s/m^4$
$W'(r, \theta)$	Integrated weight function	$V.s/m^4$
W_z	Axial component of \mathbf{W}	$V.s/m^4$
$rdrd\theta$	Area element in cylindrical coordinates	m^2
ΔU_{EF}	Flowmeter output signal	V
τ	Volume of the measuring section	m^3
θ_e	Electrode angular position	deg.

Introduction

The idea of electromagnetic flowmeter was borne at Faraday's days. It operates on his principle of electromagnetic induction - when a conductor moves through a magnetic field of given field strength, a voltage level is produced in the conductor that is dependent on the relative velocity between the conductor and the magnetic field. To extend the idea to measuring the flow of conducting liquids, the conductor is replaced by the continuous conducting liquid which flows through insulating channel, the induced voltage picked up via two electrodes (one diameter apart in most

designs) fixed in the flow channel walls and in contact with the liquid to be metered (Fig. 1). Hence the main elements of the electromagnetic flowmeters are the pick-up electrodes and the magnet [1]. Most of the reported studies and the available electromagnetic flowmeters are focused and designed where the measuring section is fully-filled with the liquid to be measured. Despite the numerous published studies regarding the electromagnetic flowmeters, the literature survey has shown that there are little published works relating the application of these devices in partially filled pipes. knowing that the partially-filled flow is frequently occurs in the; effluents from factories or processing plants feeding into sewer, influent to sewage treatment works, discharge from a sewage treatment works feeding a river and with rain retention reservoirs [2]. However, the present study is focused into the performance of these devices in partially-filled pipes.

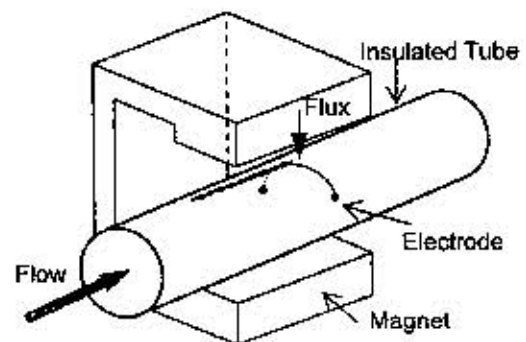

Fig. 1 Principle of Electromagnetic flowmeter [1]

Mannherz [3] in 1976 published an invention regarding advances in the main elements of the electromagnetic flowmeter to be usable in partially-filled pipes lines. The inventors used a pair of insulated arc-shaped electrodes mounted on the flow tube and at opposed positions to span a large portion of the total tube circumference. The magnet was excited by a periodically interrupted direct current where the flow signal is sampled during the steady state intervals of the magnetic field. Searle [4] in 1977, in other invention, paid the idea of the flowmeter above to maintain a large portion of the electrode area in contact with the liquid at all times. He shaped the electrodes to have an inverted T form, whose vertical leg conforms to the inner circumference of the tube and its horizontal base extends along the bottom of the tube. Yoshida et al [5] in 1993 suggested a series of developments to make the electromagnetic flowmeter measures the partially-filled flow accurately. They focused their attentions towards the compensation of both the flow velocity distribution and the conductivity of fluid. The three works above were experimental studies only. The first analytical treatments of the electromagnetic flowmeter in partially-filled pipes were reported by Zhang [6] in 1998. He assumed a uniform magnetic field; hence his study was concerned with finding of the virtual current of one pair of point electrodes to determine the weight vector distribution. He assumed the problem to be two-dimensional. He studied the effect of the liquid level on the weight

vector and discussed the optimum position of the single pair of point electrodes that gives minimum non-uniformity of the weight function. Hence, the idea behind the present article is to examine theoretically the effect of distribution of the magnetic field together with the electrodes position on the performance of these devices in partially-filled pipes.

Theory

Shercliff [7] solved the electromagnetic flowmeter equation but for specialized constraints, these are, uniform magnetic field, axis-symmetric velocity profile and two point electrodes one diameter apart. He found that the potential difference between these electrodes is given by:

$$\Delta U_{EE} = B D V_m \quad (1)$$

Where B is the uniform magnetic field, D is the pipe diameter and V_m is the liquid mean velocity. Bevir [8] introduced another comprehensive solution to expand the idea to three dimensions and any distribution of both the magnetic field and the liquid velocity by introducing the concept of the virtual current J_v such that the flow signal becomes;

$$\Delta U_{EE} = \iiint_{\tau} \mathbf{v} \cdot \mathbf{B} \times \mathbf{J}_v \, d\tau \quad (2)$$

Where τ is the flowmeter volume and the virtual current J_v can be defined as the current density that would exist in the flow

tube in the absence of magnetic field and flow if unit current entered by one electrode and extracted from the other. Bevir weight vector W is;

$$W = B \times J_v \quad (3)$$

Hence;

$$\Delta U_{EF} = \iiint_V v \cdot W \, d\tau \quad (4)$$

Many studies and designs were based on the assumption of the rectilinear flow (only the axial component of the velocity is effective and the other two are zero), so that;

$$\Delta U_{EF} = \iint_A v(r, \theta) W'(r, \theta) r \, dr \, d\theta \quad (5)$$

Where A is the cross sectional area of flow and $W'(r, \theta)$ is the integrated weight function given by ;

$$W'(r, \theta) = \int_{-\infty}^{\infty} W_z \, dz \quad (6)$$

To use equation (5) in partially filled pipes, the following essential notes should be taken into account;

i- The solution domain τ is only the filled portion of the flowmeter volume as the weight function is zero otherwise and this because of the virtual current is zero herein

ii- The distribution of the magnetic field B inside the flowmeter is assumed to be unaffected by the empty part of the pipe because of the magnetic permeability of the air is nearly same as that of water and equal to free space one ($\mu_0 = 4\pi \times 10^{-7}$).

iii- There is an essential problem arising in the partially filled electromagnetic flow measurement which can be explained as follow: The flow signal induced in the electrodes is the resultant of an infinite number of generators dispersed in the fluid. The output of each generator (Gen) (see Fig. 2b) is proportional to the local flux density and the local fluid velocity. This output voltage is shunted by the fluid surrounding the generator, as a consequence of which only a portion of signal is seen at the electrodes.

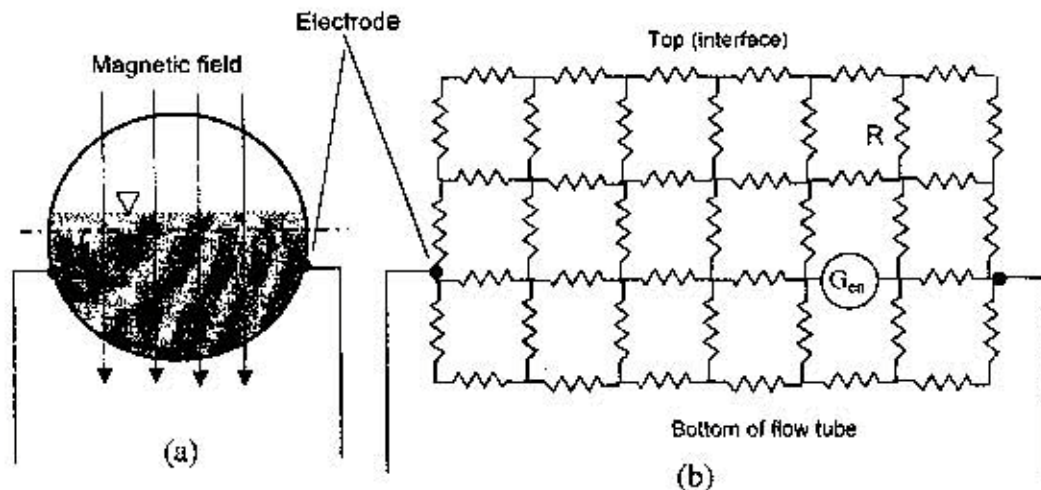

Fig. 2 (a) Uniform magnetic field. (b) Liquid equivalent resistance

The circuit surrounding the single generator (Gen) from the top to the bottom of the flow tube may therefore be represented by a network of fluid-equivalent resistors R 's [3]. Now, it is conventionally known that the magnetic field established inside the flowmeter, has a flux distribution in which the flux intensity is symmetrical from top to bottom of the flowmeter, then, for the same flow rate, any drop in the liquid level will decrease the shunting resistors. Therefore, an increase in the output flow signal amplitude is produced. Therefore, in order to minimize the effect of flowmeter signal by the liquid level drop, the flux density of the magnetic field is set up so that this density decreases progressively as one goes from the top of the meter tube to its bottom. This decrease in B density causes the generator output to progressively decrease also. The easiest mechanism of generating such distribution is decreasing the current passing through the lower coil of the magnet.

The flowmeter output signal is normalized to be dimensionless by the sensitivity criterion which is the flowmeter potential output (obtained from Equ. 5) to that flowmeter output having uniform magnetic field and axis-symmetric velocity profile (Equ.1) and as follow:

$$S = \frac{\Delta U_{FE}}{BDV_m} \quad (7)$$

V_m is the liquid mean velocity over the partially filled cross-sectional area. The larger the value of S is the stronger output flow signal meter. The present attention is to make S constant with the variation of liquid level for the same flow rate.

Numerical Computations

The distribution of the virtual current results from a scalar potential G which is governed by Laplace equation as [9]:

$$J_v = \nabla G \quad (8)$$

and

$$\nabla^2 G = 0 \quad (9)$$

On the other hand, the magnetic field equation is obtained by introducing a scalar magnetic potential F as [9]:

$$B = \nabla F \quad (10)$$

Hence;

$$\nabla^2 F = 0 \quad (11)$$

Each one of Laplace equations (Eqs. 9 and 11) were solved, separately using finite difference method of irregular discretized and as follow (for F potential):

$$F_i = \frac{1}{S_i} \left\{ \begin{aligned} & \left(\frac{1}{S_n(S_n - S_s)} + \frac{1}{2r(S_n + S_s)} \right) F(na(i)) + \\ & \left(\frac{1}{S_s(S_n + S_s)} - \frac{1}{2r(S_n + S_s)} \right) F(sa(i)) + \\ & \frac{1}{r^2} \left(\frac{1}{S_w(S_w + S_e)} \right) F(es(i)) + \frac{1}{r^2} \left(\frac{1}{S_e(S_w + S_e)} \right) F(we(i)) + \\ & \frac{1}{S_f(S_f + S_b)} F(fr(i)) + \frac{1}{S_b(S_f + S_b)} F(ba(i)) \end{aligned} \right\} \quad (12)$$

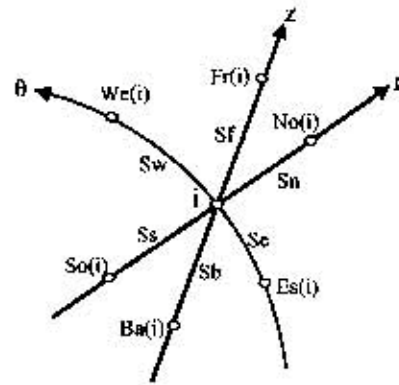

Fig.3 Cylindrical coordinates notations of the numerical solution

$$S_i = \left\{ \begin{aligned} & \frac{1}{S_n(S_n + S_s)} + \frac{1}{S_s(S_n + S_s)} + \\ & \frac{1}{r^2} \left[\frac{1}{S_e(S_e + S_w)} + \frac{1}{S_w(S_e + S_w)} \right] + \\ & \frac{1}{S_f(S_f + S_b)} + \frac{1}{S_b(S_f + S_b)} \end{aligned} \right\} \quad (13)$$

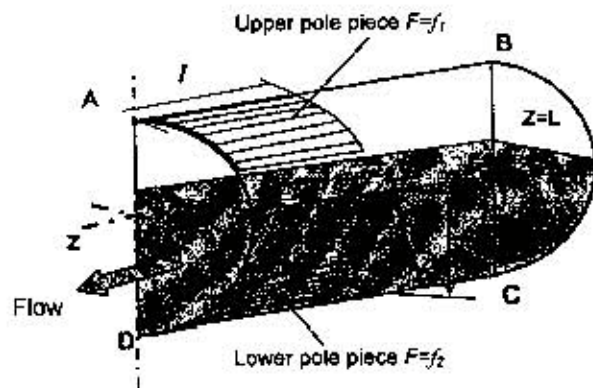

Fig.4 Boundary conditions of the magnetic field (F potential)

The notations of Eqs.(12 and 13) are shown in Fig.3. The G discretization is as same as that of Equ. (12) with replacing each F by G.

To minimize the effect of the liquid level variations on the output flowmeter signal, the magnetic strength of the upper pole must be bigger than the lower pole i.e. the symmetry about the flowmeter horizontal axis is lose. Consequently, solving one-fourth of the flowmeter volume is sufficient (see Fig.4).

The appearance of the magnetic field boundary conditions may be as follow (Fig.4);

- 1- $F=f_1$ at the upper pole piece and $F=f_2$ on the lower pole piece. Where : $f_1=I$ and $f_2=I/L_u$. Hence f_1 and f_2 represent the effect of varying the strength of the magnetic field through the flowmeter.
- 2- $F=0$ at the liner wall, the curved surface ABCD except the two pole pieces.
- 3- $\partial F/\partial \theta = 0$ at the plane surface ABCD due to symmetry.
- 4- $\partial F/\partial z = 0$ at the plane $z=0$ due to symmetry.

5- $F=0$ at the plane $z=L$, (far from the centre of the magnetic pole), where $2L$ is the length of the flowmeter. Alternatively, $\partial F/\partial z=0$ may be used instead.

On the other hand, the boundary conditions of G potential can be summarized as:

$G=1$ on the electrode surface and $\partial G/\partial n=0$ otherwise

Results and discussions

The effect of the magnet length ($2l$) on the flowmeter sensitivity is given in Fig.5. This figure implies to the appreciable improvement in the flowmeter performance (regardless of the liquid level or electrode position) by increasing the magnet length. Unfortunately, in practice, increasing the magnet length is undesirable as this requires extra power and extra flowmeter size. It is clear also from Fig.5 that increasing the magnetic length over $0.8D$ has no practical value.

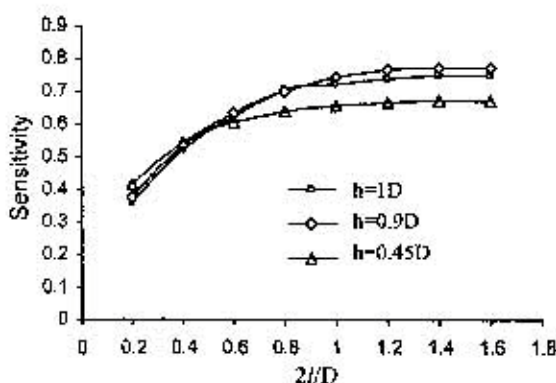

Fig. 5 Variations of flowmeter sensitivity with the length of the magnet for different liquid levels, $\theta_e=11^\circ$

The behavior of the flowmeter sensitivity versus the progressively decrease (decrease in lower coil current I_l) of the magnetic field density from the top to its bottom are given in Figs. 6 to 9. A general view on these figures may indicate to the following facts;

1-The sensitivity decreases as the current of the lower coil (I_l) becomes smaller than the current of the upper coil (I_u).

2-The sensitivity increases when the liquid level goes down. This trend completely disappears with reducing the magnitude of I_l to 25 percent of I_u as shown clearly in Fig. 7.

3-Overall insight into figures 6-8 tell us that the flowmeter sensitivity, for conventional operation ($I_l=I_u$), increases when the position of the electrodes goes below the flowmeter horizontal axis i.e. increasing θ_e . This tendency is more clear for the values of the sensitivity versus θ_e for $h=0.7D$ (see Fig. 9) where θ_e is the angular electrode position (see Fig.2) and h is the liquid level.

Regarding to the third fact above, it is well known that the flowmeter sensitivity becomes smaller when the electrode position be lower than the flowmeter horizontal axis, this is true when the magnetic field is uniformly distributed through the flowmeter [6]. In contrast with this, the sensitivity of the present flowmeter and for conventional magnet

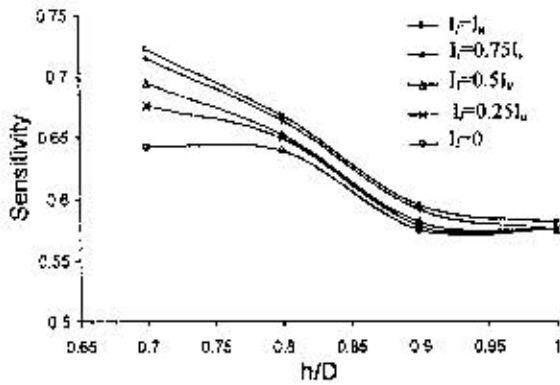

Fig.6 Effect of progressively decreasing of the magnetic field on the sensitivity for different liquid level and the same flow rate, $\theta_e=0^\circ$

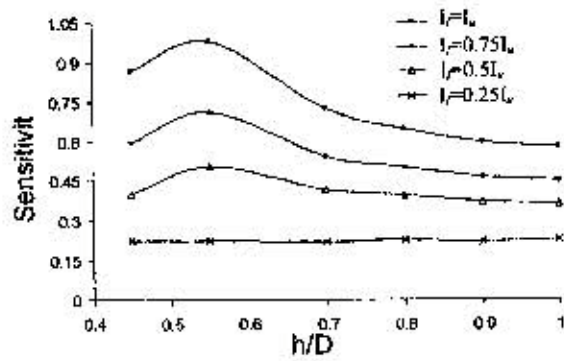

Fig.7 Effect of progressively decreasing of the magnetic field on the sensitivity for different liquid levels and constant flow rate, $\theta_e=22^\circ$

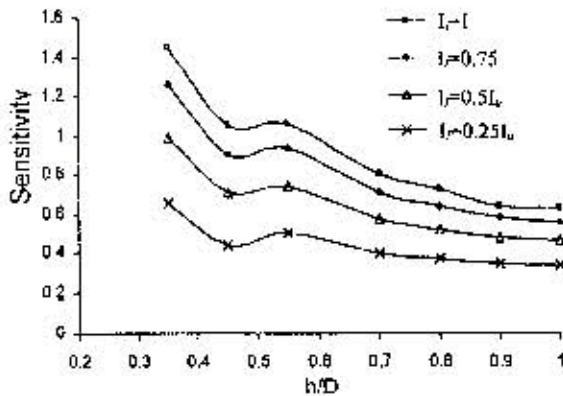

Fig.8 Effect of progressively decreasing of the magnetic field on the sensitivity for different liquid levels and constant flow rate, $\theta_e=45^\circ$

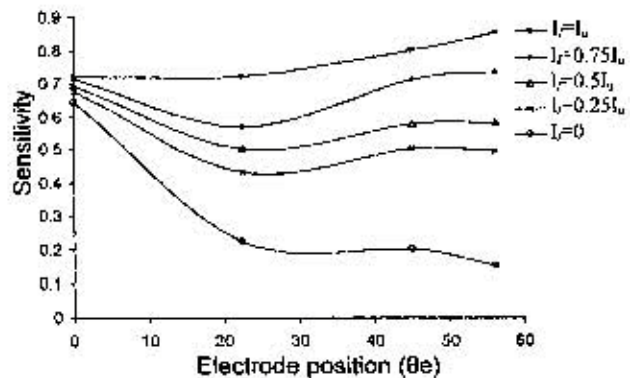

Fig.9 The effect of the progressively decreasing of the magnetic field on the trend of the sensitivity with angular position of the electrodes pair, $h/D=0.7$

operation ($I_f=I_u$), increases when the electrodes position falls below the conventional position. This tendency may be attributed to that the magnetic scalar potential values f_1 and f_2 are directly set up on the flowmeter wall i.e. the magnetic coil/yoke is in contact with pipe. Hence, when the electrodes become nearer to the magnet center (θ_e increased), regions of high strength product of the magnetic field and the virtual current (forming W , the weight vector) is

localized. These high strength weight vector regions, say singularities, give rise to the flowmeter sensitivity. The five curves of Fig. 9 clarify how the progressively reduction of the magnet field density inside the flowmeter contributes in holding the sensitivity around constant value (exactly when $I_f=0.5I_u$) although the electrode position goes down. Furthermore, when the reduction becomes sharper ($I_f<0.25I_u$) the sensitivity is monotonically decreases with decreasing θ_e .

Conclusions

The partially-filled electromagnetic flowmeter sensitivity against the variations of the liquid level for a given flow rate was studied by imposing different densities of progressively decreasing magnetic field distribution and different electrode angular positions. For a given liquid level and electrode position, the flowmeter sensitivity is appreciably improved by decreasing the magnetic field density from top to bottom of the flowmeter. The best mode obtained is that when the current of the lower coil is one-half of the current passing through the upper coil. In addition, this procedure may save power consumed by the magnet.

References

- [1] Baker R. C., 2000 "Flow Measurements Handbook, *Industrial Design, Operating Principles, Performance and Applications*" Cambridge U.K. Cambridge University Press.
- [2] Godley A. 2002 "Flow measurement in partially filled closed conduits" *Flow Measurement and Instrumentation*. Vol. 13 pp 197-201.
- [3] Mannherz D. E. and Yard J. S. 1976 "Electromagnetic flowmeter usable in less-than full fluid lines" US Patent 3,991,612.
- [4] Searle J. L. 1977 "Electromagnetic flowmeter usable in less-than full fluid lines" US patent 4,036,052.
- [5] Yoshida Y., Amata Y. and Furukawa M. 1993 "Development of a partially-filled electromagnetic flowmeter" *FLOMEKO '93 proc, 6th Int. conf. on Flow Measurement*, Korea Research Institute of Standard and Science, pp 452-459.
- [6] Zhang X. Z. 1998 "The virtual current of an electromagnetic flowmeter in partially filled pipes" *Meas. Sci. Technol.* Vol. 9 pp 1852-1855
- [7] Shercliff J. A., 1962, "The theory of electromagnetic flow-measurement" Cambridge University press.
- [8] Bevir M. K., 1970, "The theory of induced voltage of electromagnetic flowmeters". *J. Fluid Mech.*, Vol.43, pp 577-590.
- [9] Hemp J., 1975 "Improved magnetic field for an electromagnetic flowmeter with point electrodes" *J. phys. D : Appl. Phys.* Vol. 8, pp 983-1002.

