

## IMAGE TRANSFER USING LI-FI TECHNOLOGY

Hijran H. Naser<sup>1</sup>, Asmaa H. Majeed<sup>2</sup>

<sup>1</sup> College of Engineering, Al-Nahrain University, Baghdad, Iraq

<sup>2</sup> College of Information Engineering, Al-Nahrain University, Baghdad, Iraq  
{st.hijran.hamed, asmaa.h.majeed}@nahrainuniv.edu.iq<sup>1,2</sup>

Received:11/8/2021, Accepted:5/11/2021

DOI:[10.31987/ijict.5.2.193](https://doi.org/10.31987/ijict.5.2.193)

**Abstract-** Since the use of the radio-frequency (RF) portion of the electromagnetic spectrum is growing all the time, new techniques to avoid poor Internet service have become necessary, one of which is Light Fidelity (Li-Fi) technology. Li-Fi is a high-speed communication light source technology that is superior to Wi-Fi in terms of capacity, security, and accessibility. The paper is an experimental work focused on the usage of optical wireless communications (OWCs) in Li-Fi technology for transferring images of various sizes, formats, distances, and baud rates, with the results ranging from (25-280) cm, (1200- 96000) bps, and (4.7- 116) kilobytes with a time of (2.7-166) seconds.

### I. INTRODUCTION

Recently, wireless technology has advanced to the point where we now rely on it to send large amounts of data daily. Wireless communications have become increasingly vital in today's communication process. Bluetooth allows wireless devices to connect over short distances while also allowing for networking. The Bluetooth standard is based on a small microchip installed in a digital device that has a radio transceiver [1]. Electromagnetic waves, or radio waves, are the primary means through which humans communicate wireless data. Radio waves, on the other hand, can offer less bandwidth due to limited spectrum availability and intrusion. Wi-Fi is used to provide wireless coverage in a building, but Li-Fi is ideal for providing wireless data coverage with high-density in a confined area while also reducing radio interference. Light Fidelity (Li-Fi) is a term coined by Harald Haas in 2011. Because light is a widespread source of illumination, the equipment required for Li-Fi is already in place, lowering the cost of adoption. [2]- [4]. Li-Fi is a wireless communication system that employs LEDs to transport data and photodetector for detection in the receiver. This technology is known as Visible Light Communication (VLC). In comparison to other wireless communication technologies, it offers a big bandwidth, security, and low cost. The data transmission speed using Li-Fi was around 10mbps, but Dr. Haas hopes to increase it to 100mbps [5]. Some researches had been conducted to design a VLC system with various implementation. Researchers were able to successfully transfer text and image data across a distance of up to 98 cm using VLC transmission. The transmission acceptance angle is limited to 70 degrees, and the baud rate is limited to 19200 bits per second [6]. The research in [7] employs 10W super-bright white LEDs with a transmission distance of 134 cm. It may also transmit digital multimedia elements such as text, images, and video. The bit rate of the prototype is 9600 bps, and the acceptance angle is 87o. The authors of [8] offered a prototype that uses Algorithms with MATLAB 8.1 to test VLC system performance (R2013a). This experiment employed two PCs with 2.30 GHz Intel Core i3 CPUs and 2 GB of memory. The authors achieved a 10 Kbps data transfer rate across a distance of 40 cm in daylight. The Arduino Uno was utilized as the CPU in the [9] system study. Results of tests have shown success in displaying images given a distance of 50 cm, with a maximum image size of 20KB, and a lead maximum time of 30 minutes for image. The transmitter element of Li-Fi technology comprises a

microcontroller that translates data signals into binary 0's and 1's, with 0 representing OFF and 1 representing ON of the LED. The output seems constant because intensity of the LED is rapidly varied, which is undetectable by human sight [10]. The receiver consists of a photodetector that receives the transmitted signal, amplifies it to reduce noise, and then regenerates it into the required signal. The computer should be able to read the regenerated signal [11], [12]. Fig. 1 shows the block diagram of the Li-Fi full Duplex Communication system.



Figure 1: Block diagram of Li-Fi full duplex communication system

## II. IMPLEMENTATION OF THE PROPOSED SYSTEM

The system architecture is comprised of two transceiver circuits, each of which comprises a transmit and receive a portion. The transceiver section on both sides can transmit and receive data simultaneously. In the transmit section the input data is translated into binary data and sent to the LED driver. It sends binary data through the ON-OFF modulation of the LED light. A solar cell serves as the receive portion which demodulates the received signal using the 1s and 0s pattern. The solar cell detects variations in light since blinking is readily detectable and the solar cell's output is analog [13]- [16]. Thus, we could identify and demodulate the communication signal conveyed by solar cells. Fig. 2 shows the schematic diagram for the proposed Li-Fi transceiver circuit.

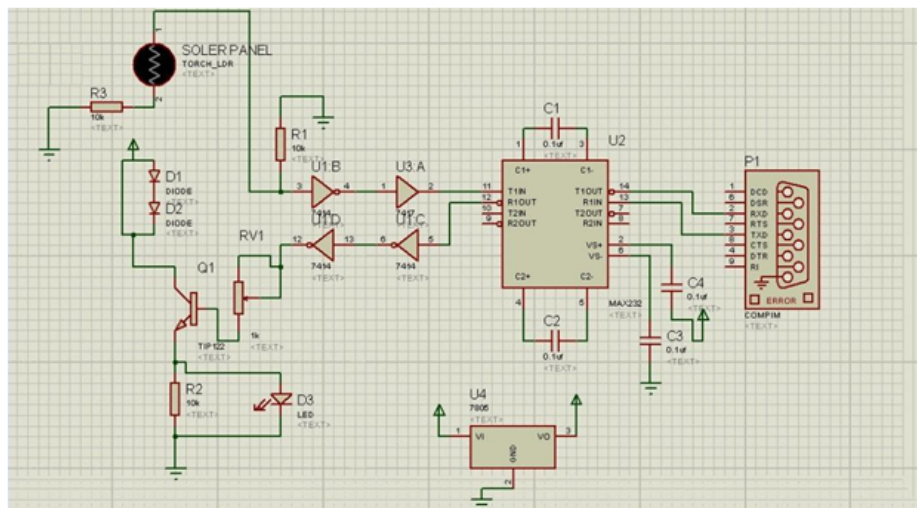

Figure 2: Schematic diagram of the proposed Li-Fi transceiver circuit

The main components used in the proposed Li-Fi transceiver are:

- RS-232 serial communication is used for the exchange of information between devices. It is used to interface between the laptop and the modules designed.
- MAX232 IC is mostly used to modify the logic of a signal. It converts RS-232 voltage level to TTL voltage level, this assists in signal transfer between devices.
- 74HC14 IC is an inverting buffer with Schmitt-trigger action. They can convert gradually changing input signals into clearly delineated, jitter-free output signals. This assists in noise reduction both at the sender and receiver end.
- TIP121 transistor works as a switch, to switching LED.
- White LED (1 watt) for the transmission of data.
- Polycrystalline solar cell (6 v, 150 mA, 1 watt, 110 mm 60 mm) which detect the modulated light, convert the optical signal to an electrical signal. It is used to acquire a higher area to preserve the line of sight between the transmitter and receiver for improved communication.

Table I List the function of each pin for the ICs used in the circuit. Fig. 3 shows a photo of the PCB of the proposed Li-Fi transceiver circuit that is printed using Altium designer software.

TABLE I  
 The function of each pin for the ICs

Pin No.	IC	Function of pin
2	DB-9	Receive data
3	DB-9	Transmit data
14(TIOUT)	Max232	Converts TTL to RS-232 and Microcontroller
13(R1IN)	Max232	Receives RS-232 signals
12(R1OUT)	Max232	Converts the signal to TTL
11(T1IN)	Max232	Receives the microcontroller's TTL signal
1,2,3,4,5,6	Max232	To capacitors
(1,3,5,13)	74HC14 IC	Inverting Schmitt trigger gate input
(2,4,6,12)	74HC14 IC	Inverting Schmitt trigger gate output
1	7805	9V
2	7805	Ground
3	7805	5V

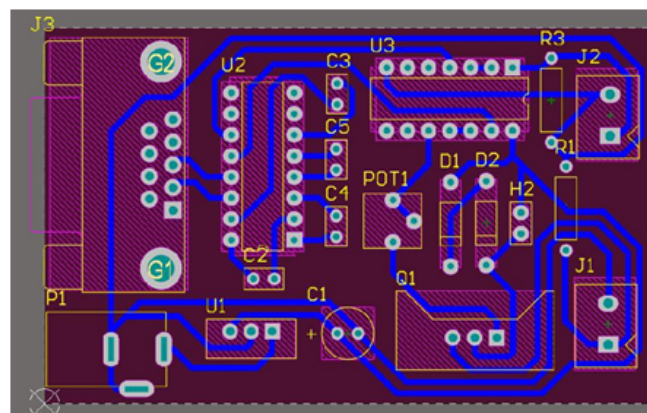

Figure 3: Photo for the PCB of the proposed bidirectional Li-Fi transceiver circuit

Fig. 4 illustrates the three-dimensional design of the proposed transceiver circuit. Fig. 5 shows the prototype of the

proposed transceiver circuit. The VLC transceiver is connected to the computer via the DB9 connector. The USB to serial converter transfers the -15V to 15V current to the IC max232, which converts it to TTL level 5V. The output of TTL can be acquired and sent to the pin 8 of the integrated circuit 7414 (free-noise buffer), which is connected to a tip121 for a high voltage and current amplifier that serves as an LED driver. The data signal is modulated on the LED indicated by the LED's on/off state switching using the RS-232 serial data transfer protocol. To facilitate the pin reversal operation, the IC 7414 Schmitt trigger is used to provide a modulation of light that will then go through pin no. 1, which is inverted to pin 2, and again inverted to pin 3. After amplification, the signal is reduced in noise on pin 2 of IC max232 and transferred to pin 11 of IC max232, where it is converted to TTL level 5V before being passed to DB9's pin 14, which is connected to pin 2 of DB9's. The signal has been readied for processing, and it may now be read by the application VLC (LIFI).

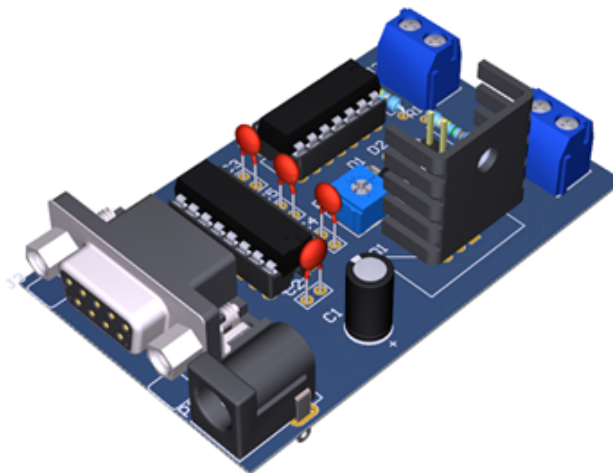

Figure 4: The circuit's three-dimensional design

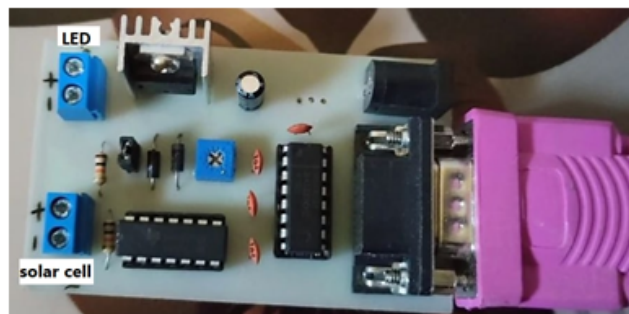

Figure 5: Hardware model of the proposed bidirectional Li-Fi based transceiver circuits

The steps involved in sending and receiving a specific image are shown in the block diagram of Fig. 6. Fig. 7. a shows the implementation of the proposed bidirectional Li-Fi-based transceiver system. When a PC1 serves as a

data source the images are sent to PC2 by flickering white LED at speeds unclear. This signal reaches the receiver (PC2) in which the solar cell converts the optical signal to electrical signals, and the original image is recovered and displayed PC2. The inverse operation is also performed, we send data from the PC2 to the PC1. Fig. 7. b shows the application of image transmission and Fig. 7. c shows the application of image reception.

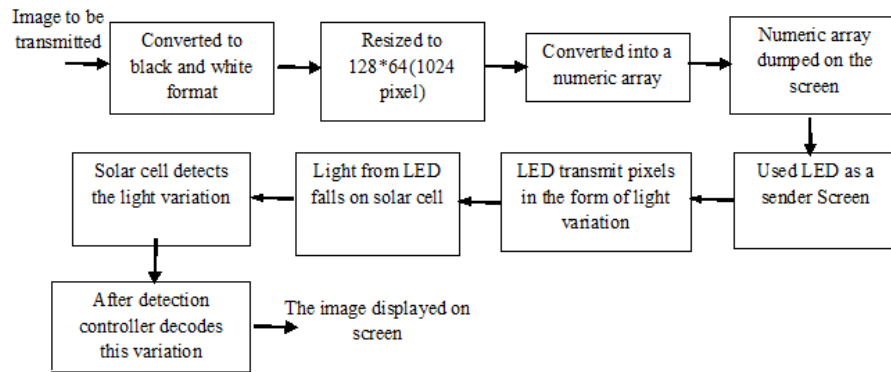
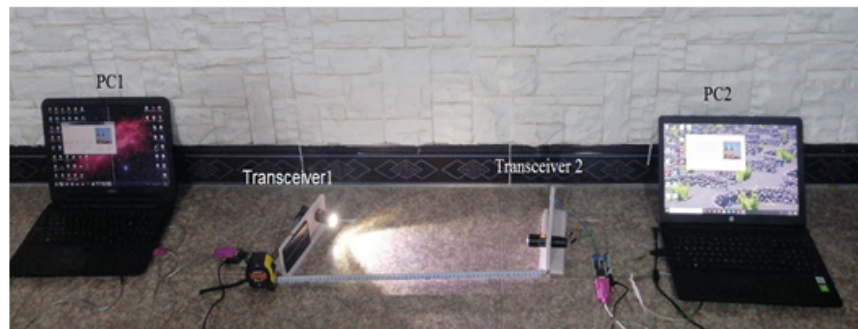
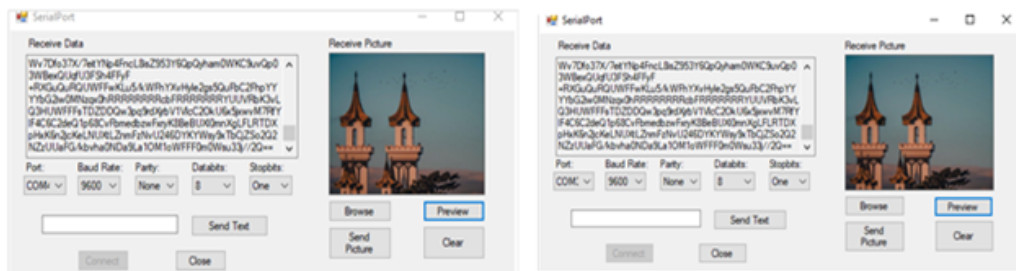

Figure 6: Block diagram illustrates the steps of sending and receiving specific image



(a)



(b)

(c)

Figure 7: (a) Testing the proposed bidirectional Li-Fi transceiver system, (b) Application of image transmission, (c) Application of image reception

### III. SOFTWARE IMPLEMENTATION

Sending visual data to the serial port was accomplished via the use of the software. The program is written in the C++ programming language for image transmission and receiving, VLC(LIFI) is employed. On both ends, the transmission and reception algorithms are set to run simultaneously, and the image to be communicated is chosen. The PCs are connected to the transceiver circuits via RS232. At both the transmitter and receiver ends, the Baud rate should be the same at both transmitting and receiving sides. The serial ports are opened at the specified Baud rate. This specified baud rate can be adjusted to achieve a high-quality image. The original image is rebuilt using the ASCII values received. Fig. 7 shows the interface developed for the communication via Li-Fi. As seen in Fig. 8, the program is used to transmit images in various sorts of formats such as \*.jpg, \*.bmp, or \*.png, when the image is selected and transmitted, it is received at the other side (2nd PC). To receive the entire image on the receiving side, the broadcast bit value must be the same as the received bit count.

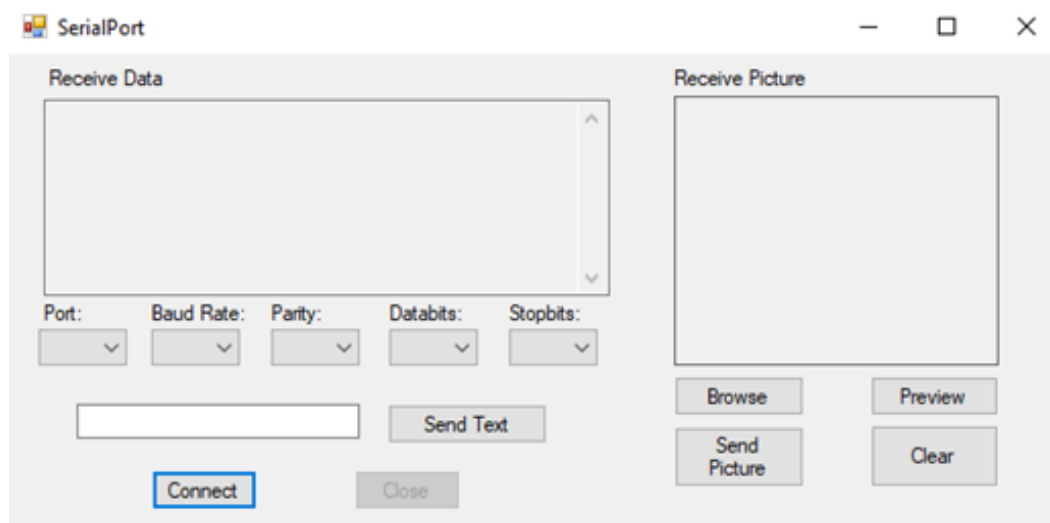

Figure 8: Interface developed for the communication via Li-Fi

### IV. EXPERIMENTAL RESULTS

The following results were obtained while conducting the experiments with the two circuits. The first Table I summarizes the results of the white LED and solar cell experiments using the full-duplex system. The results of Table II are based on transmitting of 6.5 KB (PNG) image with changing in the distance and baud rate between transmitter and receiver, where at a baud rate of 1200 bps the maximum measurement of the distance was reached, where it reached the value of 280 cm. At 2400 bps the distance reached 230 cm, and at 4800 bps the distance reached 210 cm. It is clear that the higher the baud rate, the lower the distance, so at a baud rate of 9600 bps the distance achieved of the proposed system is 150 cm. According to the practical results, a quicker data transfer rate leads to a shorter transmission distance. This scenario can be caused by the solar cell's light sensitivity. Because of the speed of the switching LED and the sensitivity of the solar

cell, increasing the baud rate increases the error rate. This issue can be avoided by using a convex lens with an LED and increasing the size of the solar cell.

TABLE II  
 Transmission distance with baud rate status

Distance(cm)	Baud rate(bps)
10-280	1200
10-230	2400
10-210	4800
10-150	9600
10-90	19200
10-70	57600
10-50	115200

In Table III, more than one type of image is transmitted at a variable baud rate. Images in PNG, BMP, and JPEG format of variable sizes with a range of baud rate from 1200 to 115200. The image size starts from 6.5(PNG) kilobytes, 10.4 (JPG) kilobytes, and 15.5 KB (BMP) kilobytes were transferred without error at various baud rates, including (1200 to 115200) bps, over a distance of 60cm. Serial data transmission speed is measured in baud rates. Serial communication uses synchronous data transfer at conventional rates including 2400, 4800, 9600, and 19200 baud, etc. The ASCII value of the input data is created, then transformed to BINARY and sent to the LED. A TTL to USB converter connects the laptop with the circuit. The association between Baud rate and transmission time will be studied further. The results demonstrate that the larger the data to be delivered, the longer the time needed, but the faster the data transfer rate, the shorter the time needed. The time relies on the magnitude of the data conveyed, and the speed depends on the light and the solar cell.

TABLE III  
 Sending variations of image (format, size) and variations of baud rates over distance of 60 cm

Type format	Baud rate(bps)	Time of transmission (sec)
6.5 KB (PNG)	1200	10.11
	2400	10.8
	4800	10.3
	9600	9.88
	19600	9.80
	57600	9.64
	115200	9.60
	10.4 KB (JPG)	1200
2400		15.30
4800		14.90
9600		14.87
19600		14.76
57600		14.62
115200		14.60
15.5 KB (BMP)		1200
	2400	20.34
	4800	20.32
	9600	20.30
	19600	20.28
	57600	20.25
	115200	20.20

Table IV shows the process of sending images of different sizes with required time of reception. It is clear from this table that the images can be sent in a reasonable amount of time, with a maximum time of 166 seconds for a 116 KB

image. From these data, we conclude that the greater the size of the data to be sent, the longer the time needed to receive data. These results are conducted when the distance between the transmitter and receiver is 60 cm.

TABLE IV  
 The process O/F sending images with variations in image size with time

size of an image (KB)	Time of transmission(sec)
4.7	2.7
6.42	10.19
9	12.6
18	14.29
29.7	42.5
57	82.24
100	144
116	166

- The experimental results depend on several factors, such as the kind, size, and intensity of the LED utilized, with a convex lens utilized. The quantity of light, as well as the intensity, affects the solar cell's reaction.
- Increasing the size of solar cell results in an increase in the receipt of data for a higher amount of light, which also results in an increase in the receipt of data and thus leads to errors in the reception of the signal.
- Additionally, the temperature increase is a negative influence on the components of the processing circuit and may harm one of its components. Data errors occur because sunlight and moisture diminish the quality of the solar cell. Results were achieved in a lighted room at typical temperatures. Table V presents comparison of recently published references related to the current research topic and current work.

TABLE V  
 Comparison of recently published references and the current work

[Ref]	Max distance	Baud Rate	File Type	Time of transmission	Size of file
[7]	98 cm	19200 (bps)	Text and image	-	-
[8]	134 cm	9600 (bps)	text, image, audio and video	-	Image (38KB) Music (1564 KB) Video (5669 KB) Text (1KB)
[9]	40 cm	-	Image	-	10KB
[10]	50 cm	-	Image	30 minutes	20KB
This work	280 cm	115200 (bps)	Image	166 second	116KB

## V. CONCLUSION

The current experimental work deals with designing a simple and low-cost communication system using LED as a transmitter, Solar cell receiver, and microcontroller unit that controls the process for transferring images in two directions between two PCs. Acceptable results were achieved by sending and receiving images of all sizes and formats successfully at different distances with baud rates ranging from 1200 to 57600 bps. The format of images that used including 6.5KB (PNG), 10.4 KB (JPG), and 15.5 KB (BMP). The farthest distance for receiving images was 280 cm in all formats. The



longer time of transmission to receive the largest size was 166 seconds for 116 kilobytes. The achieved results depend mainly on the characteristics of both the light and the solar cell and some external influences. The current project can be enhanced in future to be used for video communication and data for smartphones, tablets, etc. that can be dealt with using lights fitted in the room.

#### REFERENCES

- [1] S. Ranjith, T. Ravi, P. Umarani, and R. Arunya , "Design of CNTFET Based Sequential Circuits Using Fault Tolerant Reversible Logic" , International Journal of Applied Engineering Research, Vol. 9, No. 24, pp. 25789-25804, 2014.
- [2] A. M Sonnad, A. Gopan, N R Sailakshmi, S. Divya, R. Ambika, "Recent Advancements in Li-Fi Technology" , International Journal of Electrical, Electronics and Data Communication, Vol. 1, No. 10, 2013.
- [3] H. Elgala, R. Mesleh, H. Haas and B. Pricope , "OFDM Visible Light Wireless Communication Based on White LEDs" , in International University Bremen, 28759 Bremen, Germany , IEEE, 2007.
- [4] M. Samuel Lazar, T. Ravi, "Li-Fi Design for High Speed Data Transmission" , Asian Research Publishing Network of Engineering and Applied sciences (APRN) , Vol. 10, No. 14, 2015.
- [5] C.S. Patil, R.B. Bhamare, M.I. Rangrez, "A study of Visible Light Communication with Li-Fi Technology" , International Journal of Advanced Electronics and Communication Systems (IJAECES), ISSN: 2277-7318, 2014.
- [6] N. Yudhabrama, I. Wijayanto and S. Hadiyoso, "Low Cost Visible Light Communication Transceiver Prototype for Real Time Data and Images Transfer" , 2017 International Conference on Control, Electronics, Renewable Energy and Communications (ICCREC), pp. 7-10, 2017, doi: 10.1109/ICCEREC.2017.8226667.
- [7] I. Wijayanto, S. Hadiyoso, and R. Renggani, "Prototype of Visible Light Communication Transceiver Using Array Photo Transistor for Real Time Digital Media Transfer" , J. Phys. Conf. Ser. , Vol. 1201, No. 1, 2019, doi: 10.1088/1742-6596/1201/1/012019.
- [8] P. Shamsudheen, E. Sureshkumar, and J. Chunkath, "Performance Analysis of Visible Light Communication System for Free Space Optical Communication Link" , in: Proc. of International Conf. on Emerging Trends in Engineering, Science and Technology, Vol. 24, PP. 827-833, 2016.
- [9] A. Tsaqifurrosyid, M. Rosmiati, and M. F. Rizal, "Image Transmission Using Visible Light Communication in Data Communication" , Telkomnika (Telecommunication Comput. Electron. Control. , Vol. 18, No. 4, pp. 1771-1776, 2020, doi: 10.12928/TELKOMNIKA.V18I4.14892.
- [10] S. M. Riurean1, et al. , "A Small Step in VLC Systems - A Big Step in Li-Fi Implementation" , International Conference on Applied Sciences (ICAS2017).
- [11] C. S. Patil, R. B. Bhamare, M. I. Rangrez, "A Study of Visible Light Communication with Li-Fi Technology" , International Journal of Advanced Electronics and Communication Systems (IJAECES), ISSN: 2277-7318, 2014.
- [12] G. Madhuri, K. Anjali and R. S. Prabha, "Transmission of Data, Audio and Text Signal Using Li-Fi Technology" , IOP Conference Series: Materials Science and Engineering, No. 872,2020.
- [13] R. Karthika, S. Balakrishnan, "Wireless Communication Using Li-Fi Technology" , International Journal of Electronics and Communication Engineering (IJECE), ISSN: 2348-8387, Vol. 2, No. 3, 2015.
- [14] H. Hasan, Z. Sale H, M.Ali, and M. Kamil, "Design and Implementation of Light Fidelity System for Image Transmission" , Nonlinear Optics, Quantum Optics, Vol. 54, pp. 81-90, 2021.
- [15] Verma, S. K. , Madan, K. , & Kaur, G. , "Future of Visible Light Communication with Li-Fi Technology: A Review" , International Journal of Innovative Research in Technology, No. 2, 2015.
- [16] Ambika, A. , Aswinkumar, M. , Kamalesh, M. , & Naveen, K. , "Smart Toll Collection Using Li-Fi Technology" , In 2019 International Conference on Computation of Power, Energy, Information and Communication (ICCPEIC) , pp. 236-239, IEEE, 2019.