

## **Integral Equation Formulation to Radiation Problem from Phased Array Slots Antenna**

**Zeki A, Ahmed<sup>(1)</sup>, Ahmed H. Abood<sup>(2)</sup>, and Ranya M. Daowd<sup>(1)</sup>**

**(1) Physics Dept., College of Science, Basra University, Basra,  
Iraq, [prof\\_dr\\_zeki@yahoo.com](mailto:prof_dr_zeki@yahoo.com) and**

**[ranya\\_al\\_awad@yahoo.co.uk](mailto:ranya_al_awad@yahoo.co.uk)**

**(2) Math. Dept., College of Basic Education, Misan University,  
[ahm\\_hash2003@yahoo.com](mailto:ahm_hash2003@yahoo.com)**

### **Abstract:**

An electric field integral equation (EFIE) is used to formulate the radiation problems from conducting bodies of revolution (BoR) with aid of Method of Moments (MoM) as a numerical solution to reduced the three-dimensional problems to a two dimensional problems. In this paper phased array of slots antenna mounted on the body of revolution is analyzed to study the effect of the number of elements (slots) on the radiation pattern. Phase shift between elements of spacing  $0.5\lambda$  is applied to make the beam maximum is steered. The formulation above give us the results agree with theoretical formula, therefore, one can treat such problems numerical with efficient results.

### **Introduction:**

Several antennas are arranged in space and interconnected to produce a directional radiation pattern. Such configuration of multiple radiating elements are referred to as an array antenna, or simply, an array<sup>[1]</sup>. Elements of an array are dipoles, monopoles, loops, slots, microstrip patches, and horns are the most common types of array elements. The array antennas are classified according to<sup>[2]</sup>: Radiation pattern: broadside, end fir, intermediate, omni directional, scanned, shaped beam, multiple beam, adaptive or constrained. Geometry: linear, planar, circular, flat, three dimensional, or conformal. Elements: dipoles, monopoles, loops, slots, microstrip patches, horns, spiral, helices, long periodic, monolithic, active, electrically small. Excitation: uniform, binomial, Chabysheve, Fourier, ..... etc.

Phased array antennas consists of multiple stationary antenna elements, which are fed coherently by using variable phase or time delay control at each element to scan beam to given angles in space. Variable amplitude control is sometimes also provided for pattern shaping.

Beam steering is a concept achieved by controlling the phase or time delay between elements of an array using ,as an example, microstrip patches antenna,

because they are light and un expensive and essay to fabricate<sup>[3]</sup>, there are many of parameter affect on the radiation pattern of an array antenna such as the mutual coupling between the elements, the parameter is studied expensively by<sup>[4]</sup>. Beam steering achieved manually, electrically or electronically by fabricate the electrical or electronically circuit called beam forming circuit<sup>[5]</sup>.

In this paper a slots antenna mounted on the surface of rotational symmetric (called body of revolution BoR) is formulated using an electric field integral equation (EFIE) with the aid of Method of Moments (MoM) as a numerical solution to compute the radiation pattern of the array antenna.

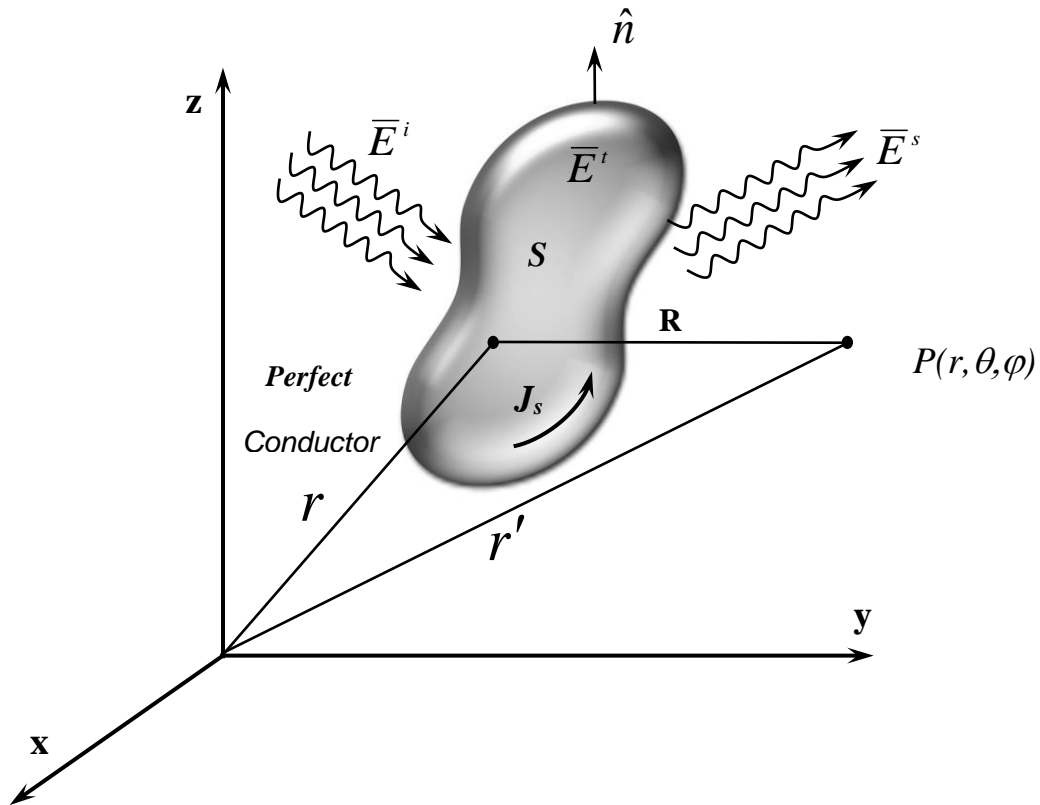
#### Formulation of the Problem:

An electric field integral equation (EFIE) is widely used to compute the scattering and radiation problems from conducting bodies<sup>[7]</sup>.

The electromagnetic scattering problem is defined as, when electric field incident on the body (conductor, dielectric, dielectric coated,...etc) the electric or magnetic surface current or both are induced on the body surface, the currents therefore re radiate an scattered fields in the surrounding area, as illustrated in the boundary condition equation for conducting bodies

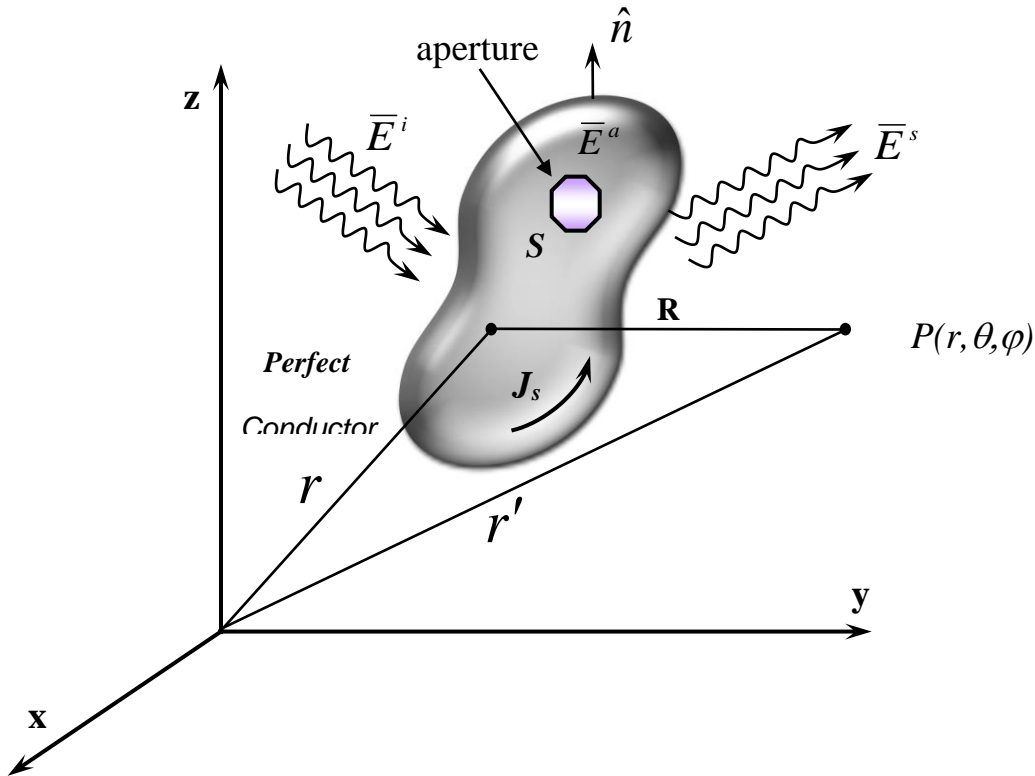
$$\hat{n} \times \bar{E}_{\text{tan}}^i = -\hat{n} \times \bar{E}_{\text{tan}}^s \quad (1)$$

Where  $\bar{E}^i$  denoted the known impressed field and  $\bar{E}^s$  the scattered field due to the currents induced on surface, while the subscript (tan) denotes tangential component on S as shown in Fig.(1).



**Fig.(1): the general scattering problem**

While the radiation problem is suppose that the excitation of the body is came from the induced currents on the body and an aperture on this body make as a source fed, as shown in Fig.(2)



**Fig.(2): the general radiation problem**

The radiation field is assumed to be come from an aperture on the body as shown in figure above determine from the tangential field of this aperture, in the radiation problem the tangential field is exist on the aperture only. From eq.(1) the scattered field can be expressed in terms of a vector potential  $\bar{A}$  and a scalar potential  $\phi$  as<sup>[8]</sup>:

$$\bar{E}^s(\bar{r}) = -j\omega\bar{A}(\bar{r}) - \nabla\phi(\bar{r}) \quad (2)$$

The EFIE can write in the form when vector and scalar potentials are applied, as

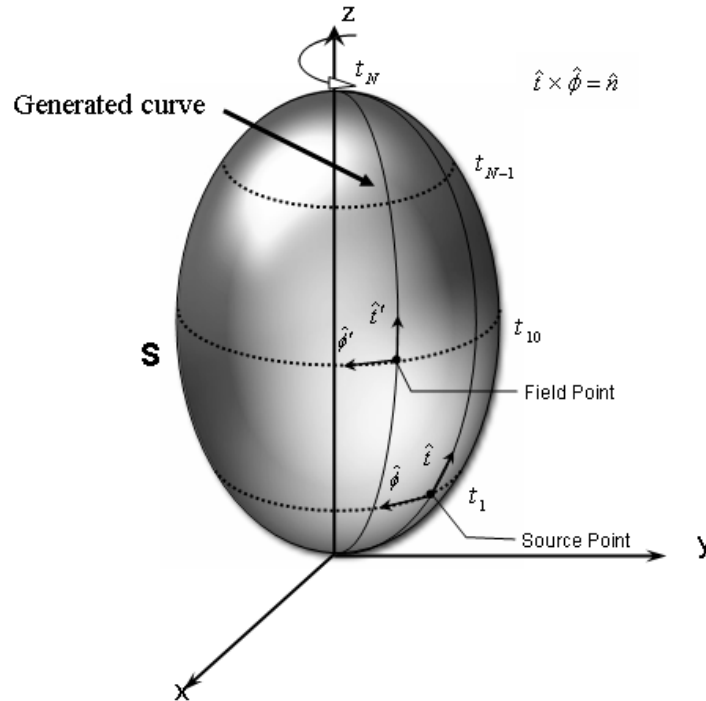
$$\hat{n} \times \bar{E}_{\text{tan}}^a = \hat{n} \times \left[ j\omega\mu \int_s \bar{J}(\bar{r})G(\bar{r}, \bar{r}')ds - \frac{\nabla}{j\omega\epsilon} \int_s \nabla' \cdot \bar{J}(\bar{r})G(\bar{r}, \bar{r}')ds \right]_{\text{tan}} \quad (3)$$

Where  $E^a$  is the electric field in the aperture,  $\omega, \mu, \epsilon$  the angular frequency, permeability and permittivity respectively and  $G$  is Green's function for free-space which can be defined as<sup>[8]</sup>:

$$G(\bar{r}, \bar{r}') = \frac{e^{-jk|\bar{r}-\bar{r}'|}}{4\pi|\bar{r}-\bar{r}'|} \quad (4)$$

The first step of MoM to solve Eq.(3) is to represent the electric surface by an equivalent surface current.

The symmetric of the BoR shown in fig.(3) allow to define a set of expansion functions,  $J_j$  and the current on S approximated by



**Fig(3): generic body of revolution.**

$$\bar{J} = \sum_j I_j \bar{J}_j \quad (5)$$

Where  $I_j$  are constant to be determined, j is the number of annul ring when BOR are divided to N segments.

Substituting eq.(5) into eq.(3) we find

$$L\left(\sum_j I_j \bar{J}_j\right) = \bar{E}_{\tan}^a \quad (6)$$

The second steep of MoM is define a set of weighting functions  $W_i$  and the inner product of eq.(6) with each  $W_i$  is taken<sup>[8]</sup>:

$$\sum_j I_j \langle \bar{W}_i, L(\bar{J}_j) \rangle = \langle \bar{W}_i, \bar{E}_{\tan}^i \rangle \quad (i=1,2,3,\dots) \quad (7)$$

We now define the generalized network matrices:

$$[Z] = \left[ \langle \bar{W}_i, L(\bar{J}_j) \rangle \right] \quad (7.a)$$

and:

$$[V] = \left[ \langle \bar{W}_i, \bar{E}_{\tan}^i \rangle \right], \quad (7.b)$$

$$[I] = [I_j] \quad (7.c)$$

So eq.(7) can be written as:

$$[Z][I] = [V] \quad (8)$$

$[Z]$  is the generalized impedance matrix and  $[Y] = [Z]^{-1}$  is the generalized admittance matrix,  $[V]$  is the excitation matrix, an  $[I]$  is column matrix of unknown coefficient. The solution of (8):

$$[I] = [Y][V] \quad (9)$$

The impedance elements of eq.(7.a) are explicitly<sup>[8]</sup>

$$Z_{ij} = \left[ j\omega\mu \iint_s (W_i \cdot J_j) ds - \frac{1}{j\omega\epsilon} \iint (\nabla \cdot W_i)(\nabla' \cdot J_j) ds \right] \frac{e^{-jkR}}{4\pi R} \quad (10)$$

The current expansion in eq.(5) becomes

$$\bar{J}(r') = I_{nj}^t \bar{J}_{nj}^t(t', \varphi') + I_{nj}^\varphi \bar{J}_{nj}^\varphi(t', \varphi') \quad (11)$$

where

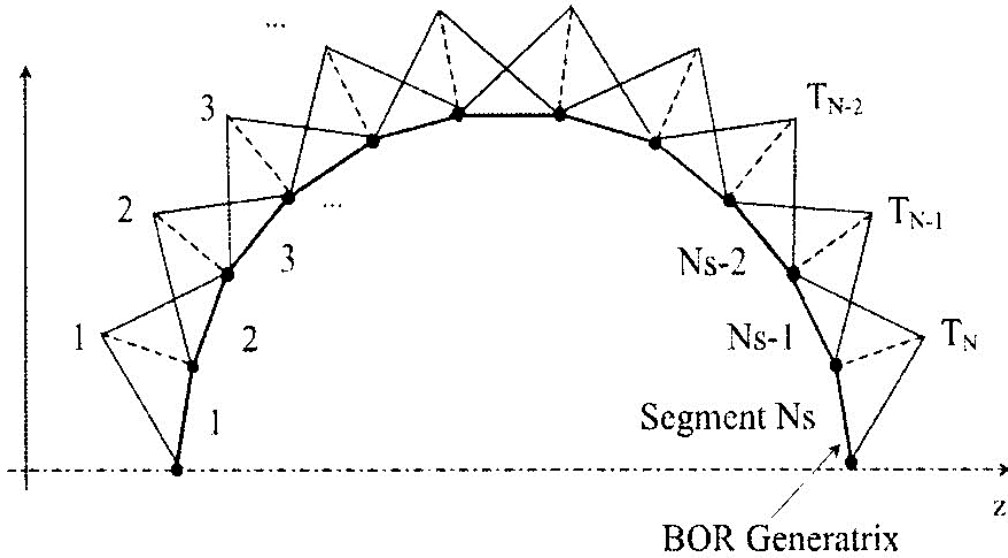
$$\bar{J}_{nj}^\alpha(t', \varphi') = \hat{u}_\alpha f_j(t') e^{jn\varphi} \quad ; \quad \square \square t \text{ or } \square \quad \square \square \square \square$$

and  $f_i(t')$  is a triangle basis function as shown in Fig.(4), for testing function using Galerkin's approach, we chose

$$W_{mi}^\beta(t, \varphi) = \hat{u}_\beta f_i(t) e^{-jm\varphi} \quad ; \quad \square \square t \text{ or } \square \quad (13)$$

Which is a complex conjugate of  $J_{nj}^\alpha$ , as<sup>[8]</sup>

$$(Z_n^{\alpha\beta})_{ij} = \left[ j\omega\mu \iint_s (W_{ni}^\alpha \cdot J_{nj}^\beta) ds - \frac{1}{j\omega\epsilon} \iint (\nabla \cdot W_{ni}^\alpha)(\nabla' \cdot J_{nj}^\beta) ds \right] \frac{e^{-jkR}}{4\pi R} \quad (14)$$



**Fig(4): Overlapping Triangle Basis Function.**

Eq.(14) are evaluated numerically (for details see [8]), the system of linear equation is given by

$$\begin{bmatrix} [Z_n^{tt}] \\ [Z_n^{\varphi t}] \end{bmatrix} \begin{bmatrix} [I_n^t] \\ [I_n^\varphi] \end{bmatrix} = \begin{bmatrix} [V_n^t] \\ [V_n^\varphi] \end{bmatrix} \quad (15)$$

For radiation problem there are two components of surface current  $\bar{J}^t$  and  $\bar{J}^\varphi$ , the excitation of the body is given by

$$\begin{aligned} E_\theta &= \delta(\theta - \pi/2) / a \\ E_\varphi &= -\delta(\theta - \pi/2) / a \end{aligned} \quad (16)$$

Substituting eq.(23) into eq.(21) one can get

$$(V_n^\alpha)_i = \langle W_{ni}^\alpha, E^a \rangle = \iint_S W_{ni}^\alpha, E^a(t, \varphi) ds = \int_{si} e^{-j\varphi} d\varphi \int_o^N \hat{u}_\alpha f_i(t) E^a(t, \varphi) \rho dt \quad (17)$$

Which can be written as:

$$(V_n^\alpha)_i = a_n U_i^\alpha$$

Where  $a_n$  is the aperture coefficient and  $U_i^\alpha$  is the integral part of eq.(17) for  $E_\square$  and  $E_\square$  with respect to slot location  $S_i$ , which can be solved analytically, with the help of the properties of Dirac-delta function, so

$$U_i^\alpha = \begin{cases} U_i^t = \int_0^N \hat{u}_t f_i(t) \cdot E_\theta^a dt = 1 \\ U_i^\phi = \int_0^N \hat{u}_\phi f_i(t) \cdot E_\phi^a dt = 1 \end{cases} \quad (18)$$

And

$$a_n = \int_0^{2\pi} e^{-jn\phi} d\phi = 2\pi \quad \text{for } n = 0 \quad (19)$$

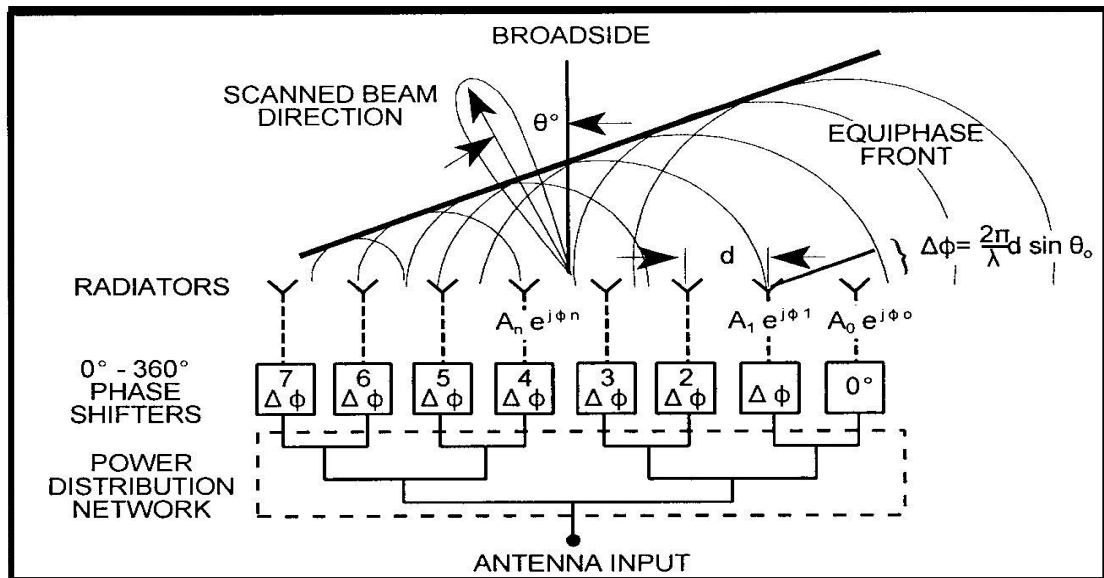
Therefore eq.(17) becomes

$$\begin{aligned} (V_0^{t\theta})_i &= 2\pi \\ (V_0^{\phi\phi})_i &= 2\pi \end{aligned} \quad (20)$$

Phased Array Slots Antenna:

Linear phased array with equal spaced elements easiest to analyzed and forms basic for most array designs.

Fig.(5) illustrate the linear phased array antenna fed with elements spacing  $d^{[2]}$ .



**Fig.(5) : linear phased array antennas with corporate fed.**

By controlling the phase and amplitude of excitation to each elements, as depicted, we can control the direction and shape of the beam radiated by array. The phase excitation,  $\phi_n$ , controls the beam pointing angle,  $\theta_0$ , in phased array.



In this work the elements of a linear array are the slots with equal space of  $0.5\lambda$  are mounted on the BoR and phase factor must be added to eq.(20) is

$$(V_0^{t\theta})_i = 2\pi e^{j\xi}$$

$$(V_0^{\phi\phi})_i = 2\pi$$

21

$$\xi = jNs \sum_{i=1}^{Ns} \phi_i$$

Where  $N_s$  is the number of slots,  $\phi_i$  is the  $\lambda_s/N_s$  and  $\lambda_s$  is scanning angle.

The approximation of plane wave which is depend on Mautz and Harrington<sup>[8]</sup> approximation and treatment is used here. By which, any linear measurement of the field from the current  $\bar{J}_s$  on a body S can be expressed as linear functional, that is

$$measurement = \iint_s \bar{E}^r \cdot \bar{J} ds \quad (22) \text{ Where}$$

$\bar{E}^r$  is a known function, and  $\bar{J}$  is surface current density. Now, using eq.(5) to obtain:

$$measurement = [R][I] \quad (23)$$

Which can be written as

$$measurement = \begin{bmatrix} R_n^t & R_n^\phi \end{bmatrix} \begin{bmatrix} Y_n^{tt} \\ Y_n^{\phi t} \end{bmatrix} \begin{bmatrix} Y_n^{t\phi} \\ Y_n^{\phi\phi} \end{bmatrix} \begin{bmatrix} V_n^t \\ V_n^\phi \end{bmatrix} \quad (24)$$

Where the sub matrices  $[Y]$  are obtained after  $[Z]$  matrix is inverted and  $[R]$  is the measurement matrix. It has been shown that the radiation field from currents  $\bar{J}$  on S is given by:

$$\bar{E} \cdot \hat{u} = -\frac{j\omega\mu}{4\pi r} e^{-jk r} [R][I] \quad (25)$$

Where  $\hat{u}$  is unit vector which specifies the incident wave polarization, and  $\bar{E}^r$  can be defined as a plane wave as the following:

$$\bar{E}^r = \bar{E}_\theta^r + \bar{E}_\phi^r = \hat{u}_\theta^r e^{-jk \cdot \bar{r}} + \hat{u}_\phi^r e^{-jk \cdot \bar{r}} \quad (26)$$

From the equation (22), which shows tow polarized case

$$(\mathfrak{R}_n^{t\theta})_i = \langle J_{ni}^t, \bar{E}_\theta^r \rangle$$

$$(\mathfrak{R}_n^{\phi\theta})_i = \langle J_{ni}^\phi, \bar{E}_\theta^r \rangle$$

For the  $\theta$ -polarized, and

$$(\mathfrak{R}_n^{t\phi})_i = \langle J_{ni}^t, \bar{E}_\phi^r \rangle$$

$$(\mathfrak{R}_n^{\phi\phi})_i = \langle J_{ni}^\phi, \bar{E}_\phi^r \rangle$$

For the  $\square$ -polarized

The values of  $(\mathfrak{R}_n^{t\theta})_i, (\mathfrak{R}_n^{\phi\theta})_i, (\mathfrak{R}_n^{t\phi})_i, (\mathfrak{R}_n^{\phi\phi})_i$  can be found out as the following<sup>[8]</sup>:

$$\begin{aligned} (\mathfrak{R}_n^{t\theta})_i &= \sum_{q=1}^4 \pi j^{n+1} T_q e^{jkz_q \cos(\theta_r)} \left[ \sin(\nu_q) \cos(\theta_r) (J_{(n+1)} - J_{(n-1)}) + 2j \cos(\nu_q) \sin(\theta_r) J_n \right] \\ (\mathfrak{R}_n^{\phi\theta})_i &= \sum_{q=1}^4 j \pi j^{n+1} T_q e^{jkz_q \cos(\theta_r)} \cos(\theta_r) (J_{(n+1)} + J_{(n-1)}) \\ (\mathfrak{R}_n^{t\phi})_i &= \sum_{q=1}^4 -j \pi j^{n+1} T_q e^{jkz_q \cos(\theta_r)} \sin(\nu_q) (J_{(n+1)} + J_{(n-1)}) \\ (\mathfrak{R}_n^{\phi\phi})_i &= \sum_{q=1}^4 \pi j^{n+1} T_q e^{jkz_q \cos(\theta_r)} (J_{(n+1)} - J_{(n-1)}) \end{aligned} \quad (27)$$

It is important to noted that  $(\mathfrak{R}_n^{t\theta})_i, (\mathfrak{R}_n^{\phi\phi})_i$  are even function in n while  $(\mathfrak{R}_n^{\phi\theta})_i, (\mathfrak{R}_n^{t\phi})_i$  are odd in n, and the excitation matrix  $[V]$  differs from the measurement matrix  $[R]$  only by the sign of n .

If the incident wave is supposed to be plane wave in the direction of axis of symmetry ( $\theta = 0^\circ$  or  $180^\circ$ ), it is possible to write the following relation as :

$$(V_n^{pq})_i = (\mathfrak{R}_{-n}^{pq})_i$$

Where  $pq$  represents  $t\theta, \phi\theta, t\phi, \phi\phi$  .

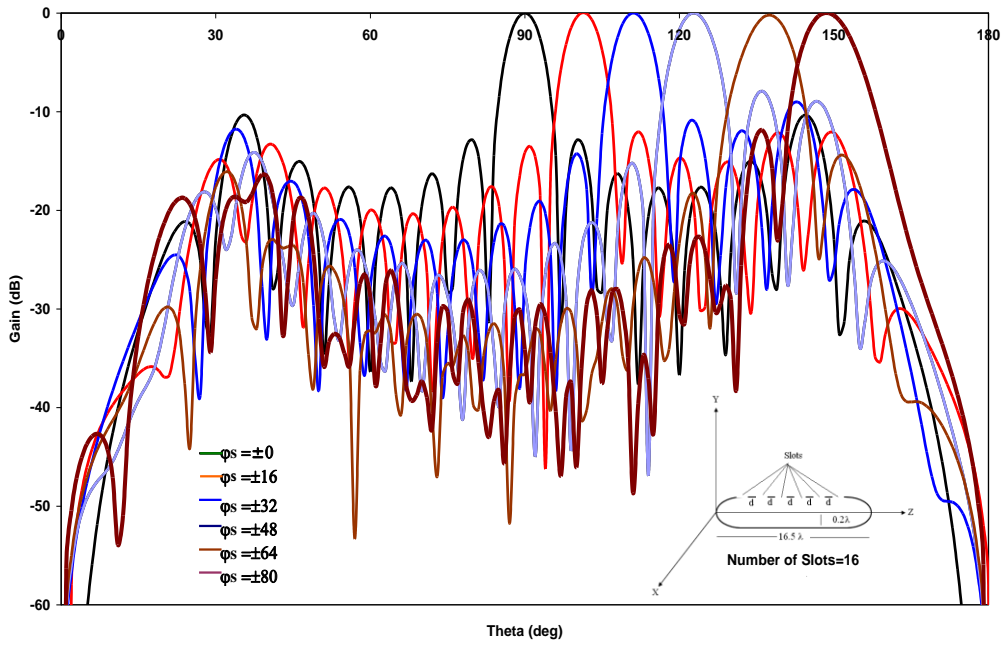
#### Numerical Results:

The radiation field components can be derived using eq.(25) and eq.(26), to obtain<sup>[9]</sup>:

$$\begin{aligned} E_\theta &= \frac{j\mu\omega}{4\pi r} [R_0^{t\theta} [Y_0^{tt} [V_0^{t\theta}]] \\ E_\phi &= \frac{-j\mu\omega}{4\pi r} [R_0^{\phi\phi} [Y_0^{\phi\phi} [V_0^{\phi\phi}]] \end{aligned} \quad (28)$$

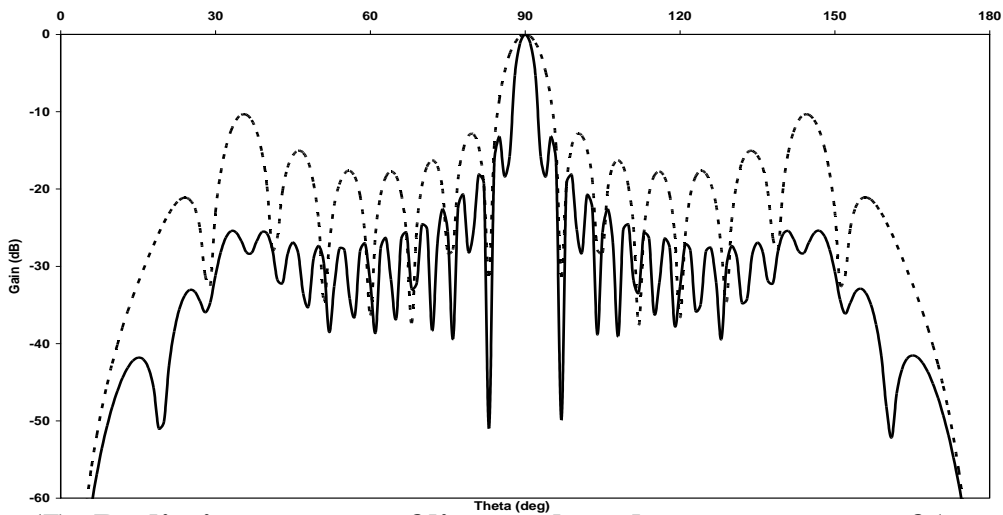
The values of  $(Y_0^{tt})$  and  $(Y_0^{\phi\phi})$  are the inverse of  $(Z_0^{tt})$  and  $(Z_0^{\phi\phi})$  respectively.

Eq.(28) is solved source code has been build to compute the radiation pattern. Fig.(6) illustrated the result of radiation pattern of 16 slots of spacing  $0.5\lambda$  are mounted on the BoR as a ended sphere cylinder of radius  $0.2\lambda$  and total length is  $16.5\lambda$  as a function of steering angles.



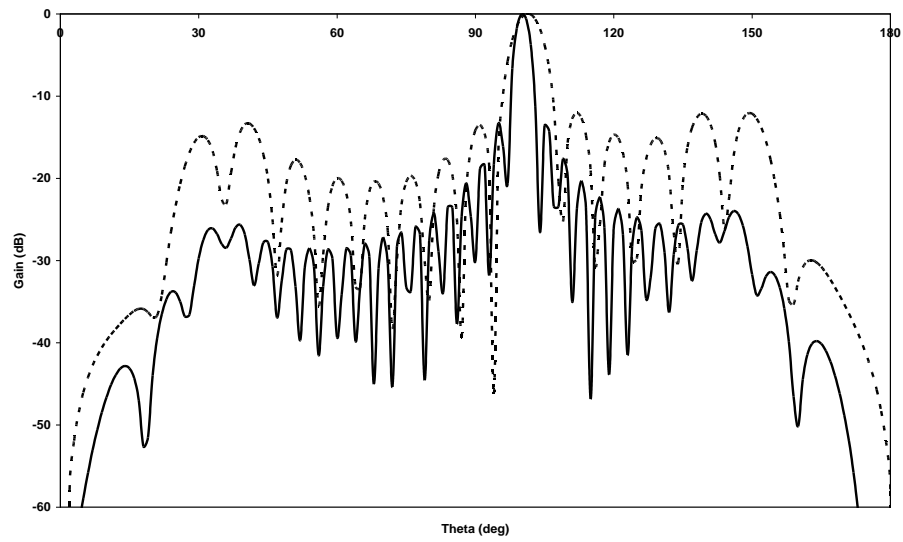
**Fig.(6): Radiation pattern of linear phased array antenna of 16 slots of  $0.5\lambda$  w.r.t steering angle.**

The effect of increasing the number of slots to 32 on the radiation pattern is depicted in Fig.(7).

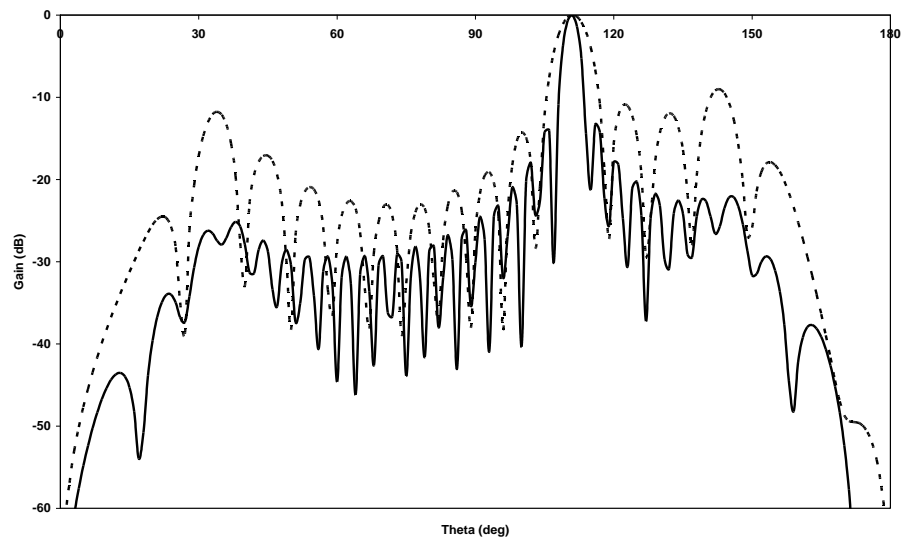


**Fig.(7): Radiation pattern of linear phased array antenna of (.....)16 slots and (—) of 32 slots spaced by  $0.5\lambda$ .**

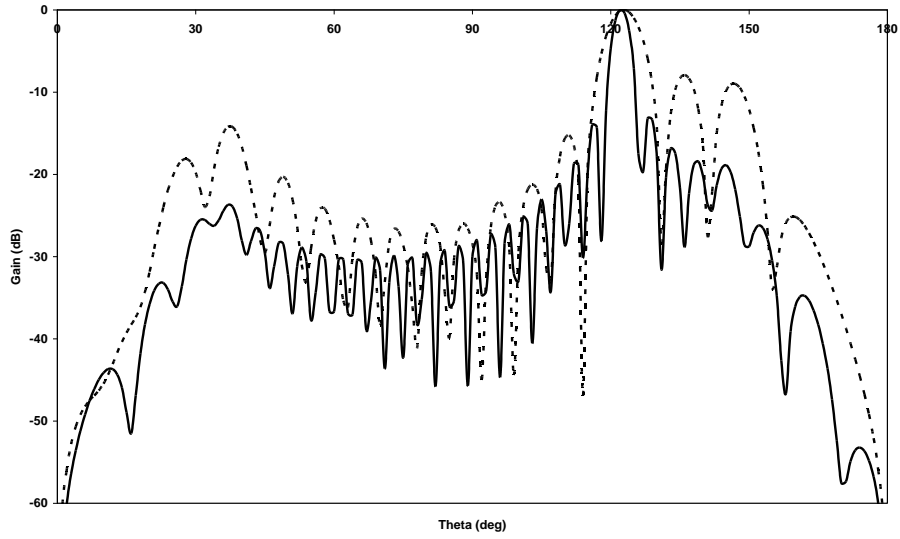
The effect of steering angle and the number of slots are illustrated in Fig.(8).



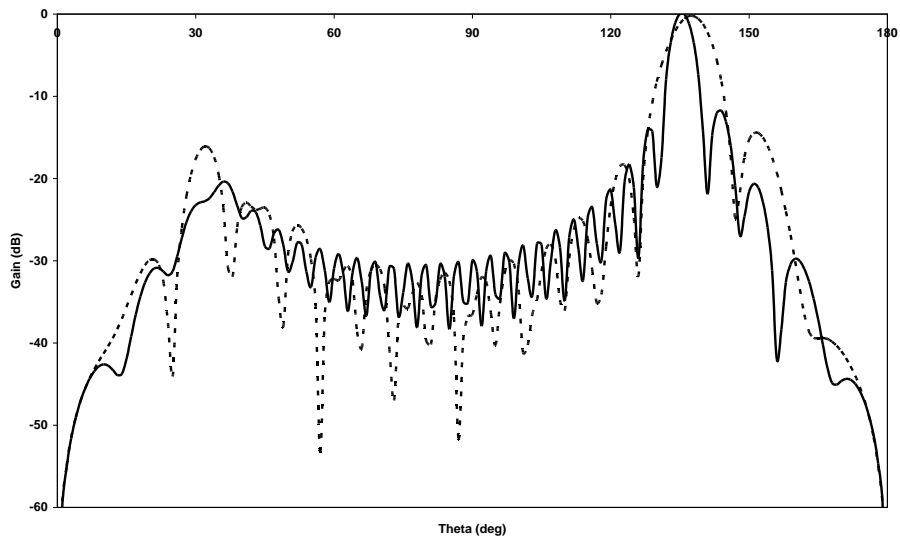
(a)



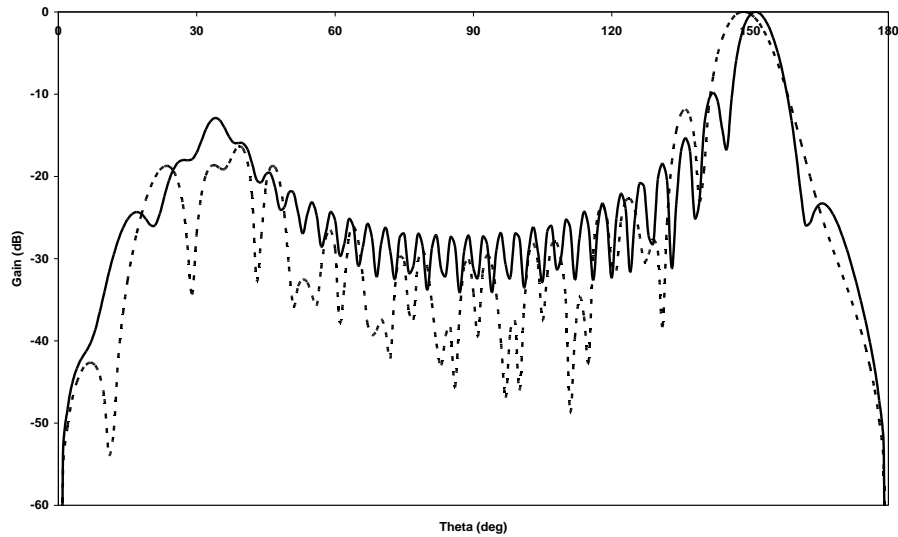
(b)



(c)



(d)



(e)

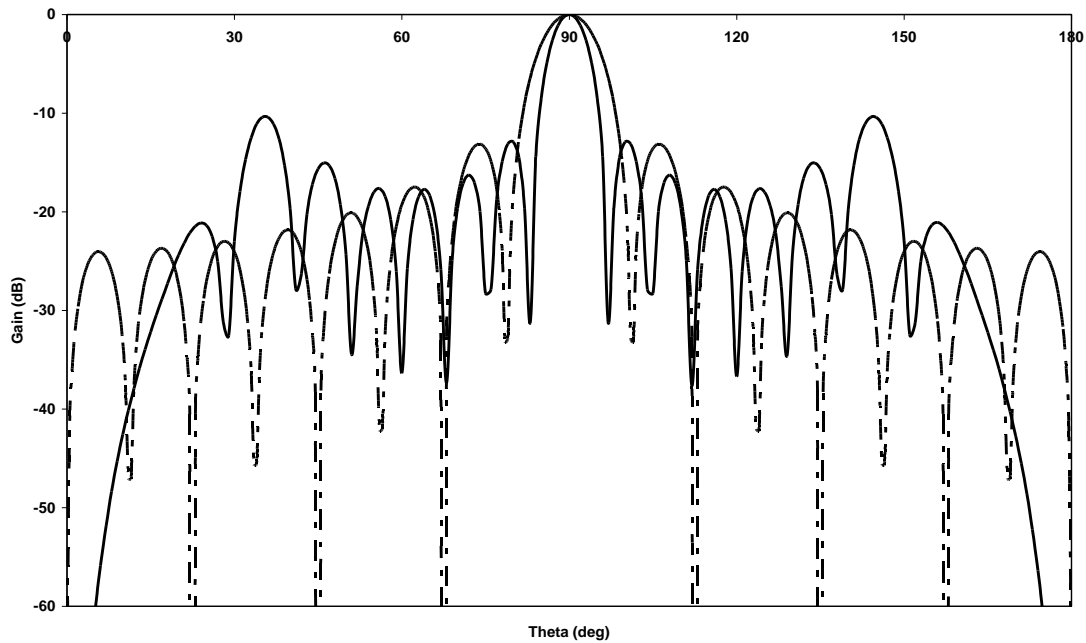
**Fig.(8): Radiation pattern of linear phased array antenna of 16 slots (.....) and (—) of 32 slots of  $0.5\lambda$  with steering angle (a)  $16^\circ$ , (b)  $32^\circ$ , (c)  $48^\circ$ , (d)  $64^\circ$ , and (e)  $80^\circ$ .**

**Conclusions:**

Phased array antennas is an array whose main beam maximum direction is controlled by varying the phase or time delay to elements

In this work one can conclude that:

The EFIE formulation with MoM as a numerical solution give a good results when compared with that of uniform excited equal spaced linear array (*UE-ESLA*) given in texts of array antenna such as number of SLL which are equal to  $(N-2)$  where  $N$  is the number of elements, as shown in Fig.(9), increasing the number of slots antennas, the directivity of array antenna increased and become more directive (see Fig.(7)). Controlling the phase between the array elements make the main loop scan or steered for a given scan angle. The shift in the main loop with a given scan angle is independent on the number of slots (see Fig.(8)).



**Fig.(9): Radiation pattern of UE-ESLA (.....) and slots (—) of 16 elements of  $0.5\lambda$**

### References:

- 1- W. L. Stutzman and G. A. Thiele, "*Antennas Theory and Design*", John Wiley & Sons, Ltd, N. Y., 1998.
- 2- J. N. Sahalos, "*Orthogonal Method for Array Synthesis: Theory and ORAMA Computer Tool*", John Wiley & Sons, Ltd, N. Y., 2006.
- 3- J. J. H. Wang, D. J. Triplett and C. J. Stevens, "Broadband/Multi band Conformal Circular Beam-Steering Array", *IEEE Trans. Anten,& Propag.*, Vol. 54, No. 11, pp:3338-3346, 2006.
- 4- M. M. Dawoud and M. K. Amjad, "Analytical Solution for Mutual Coupling in Microstrip Patch Antenna Arrays", *The Arabian Journal for Science and Engineering*, Vol. 33, No. 1B, April, 2006.
- 5- J. Largqvist, "Design and Analysis of an Electrically Steerable Microstrip for Ground to Air Use", M. Sc. Thesis, May, 2002.
- 6- C. Valentine and A. de Leon, "Design, Analysis, and Fabrication of Microstrip Phased Array Antennas". A report submitted to the Dept. of Elec. Eng., University of Manitoba, 2002.
- 7- R. F. Harrington, "*Field Computation by Moment Method*", MacMillan , N. Y., 1993.

- 8- J. R. Mautz and R. F. Harrington, " Radiation and Scattering from Bodies of Revolution", Appl. Sci. Res., Vol. 20, pp: 405:45, 1969.
- 9- R. M. Dawod, "Radiation Fields of Aperture Antennas on a Conducting Bodies of Revolution (BoR) Using Method of Moments (MoM)", An M. Sc. Thesis Submitted to College of Science, Basra University, Iraq, 2007.

## صيغة المعادلة التكاملية لمسائل الإشعاع من مصفوفة الهوائيات الشقية الطورية

زكي عبدالله احمد<sup>(1)</sup> احمد هاشم عبود<sup>(2)</sup> رانيا مسلم داود<sup>(1)</sup>

(1) قسم الفيزياء-كلية العلوم-جامعة البصرة- البصرة-العراق-

[ranya\\_al\\_awad@yahoo.co.uk](mailto:ranya_al_awad@yahoo.co.uk) و [prof dr zeki@yahoo.com](mailto:prof_dr_zeki@yahoo.com)

(2) قسم الرياضيات-كلية التربية الاساسية-جامعة ميسان-ميسان-العراق -

[ahm\\_hash2003@yahoo.com](mailto:ahm_hash2003@yahoo.com)

### الخلاصة:

تم استخدام معادلة المجال الكهربائي التكاملية لمعالجة مسائل الإشعاع من الأجسام المتولدة من التدوير بمساعدة طريقة العزوم كطريقة عددية الغاية منها تحويل المسألة ثلاثية الأبعاد إلى مسألة ثنائية الأبعاد. في هذا البحث تم تحليل مصفوفة الهوائيات الطورية المكونة من الشقوق المثبة على الجسم المتولد من التدوير ودراسة تأثير عدد العناصر (الشقوق) على هيكل الإشعاع. فضلا عن تطبيق فرق طور بين العناصر التي تبعد عن بعضها البعض مسافة نصف طول موجة على اتجاه الفلقة الرئيسية لهيكل الإشعاع. المعالجة أعلاه أعطتنا نتائج جيدة مقارنة مع العلاقات النظرية المتعلقة بالموضوع، لذلك تعد هذه الطريقة جداً كفاءة لمعالجة مثل هذه المسائل.