

Developing Industrial ATmega328p Based Microcontroller Board

Noor Salim Joher^a Mahmood Ali Janabi Ali Fawzi Al-shammari, and Ahmed Salman Al Tomaa

University of Kerbala, College of Engineering, Department of Electrical and Electronic Engineering,

E_mail: noor.saleem@s.uokerbala.edu.iq

Kerbala_Iraq

Abstract

This paper explores recent advancements in industrial microcontroller platforms, with a specific emphasis on the Kerduino microcontroller. The investigation systematically examines distinctive features of Kerduino, encompassing considerations in system design, voltage regulation, board programming interfaces, and mechanical robustness. The Kerduino microcontroller is highlighted for its outstanding performance in industrial settings, characterized by a wide voltage tolerance range (12-30 V), a robust power output of 5A (25W), and notable durability under challenging environmental conditions, facilitated by robust wiring connections and anti-vibration mechanisms. The study delves into the engineering intricacies of Kerduino's design, accentuating its adaptability and customization capabilities for seamless integration with diverse sensors, actuators, and shields. Moreover, the paper underscores Kerduino's open-source nature, promoting collaborative and transparent development. Through a comparative analysis, the paper positions Kerduino as a versatile, dependable, and resilient choice for industrial microcontroller applications, presenting innovative advancements that significantly contribute to the evolving field of industrial automation and control systems. The separate delineation of the Kerduino platform's development methodology further affirms its systematic approach, optimizing design, refinement processes, and expediting time-to-market, thus solidifying its standing as an innovative solution in industrial microcontroller technology.

Keywords: Kerduino, Industrial Microcontroller, PCB Design, Outdoor Applications, and Voltage Regulators

تطوير لوح صناعي مبني على المتحكم الدقيق ATmega328p

نور سليم جوهر، محمود علي الجنابي، علي فوزي الشمري، أحمد سلمان آل طعمة
جامعة كربلاء \ كلية الهندسة- قسم الكهرباء والإلكترونيات. العراق

الخلاصة

تناولت هذه الدراسة التطورات الحديثة في مجال منصات التحكم الدقيقة الصناعية، وترتبط بشكل خاص على وحدة التحكم الدقيقة Kerduino. تقوم الأبحاث بمحسب شكل منهجي السمات المميزة لـ Kerduino، مع التركيز على عوامل تصميم النظام، وتنظيم الجهد، ووحدات برمجة اللوحة، والمتانة الميكانيكية. تتميز وحدة التحكم الدقيقة Kerduino بأدائها المتميز في البيئات الصناعية، مع نطاق تحمل واسع للجهد (١٢-٣٠ فولت)، وإخراج طاقة يبلغ ٥ أمبير (٢٥ واط)، ومتانة ملحوظة في ظل الظروف البيئية الصعبة. يتعمق البحث في التعقيدات الهندسية لتصميم Kerduino، مشدداً على قدرتها على التكيف وتخصيص التكمال مع أجهزة الاستشعار والمحركات. تؤيد الورقة على طبقة Kerduino مفتوحة المصدر، مما يعزز التنمية التعاونية والشفافية، وتضع Kerduino خار متعدد الاستخدامات وقابل للاعتماد ومرن لتطبيقات وحدات التحكم الدقيقة الصناعية. يؤيد التحديد المنفصل لمنهجية تطوير Kerduino على نهجها المنهجي وتحسين التصميم، وبالتالي تعزيز مكانتها حلاً مبتكراً في تكنولوجيا وحدات التحكم الدقيقة الصناعية. الكلمات المفتاحية: Kerduino، تحكم صناعي، تصميم دوائر مطبوعة، تطبيقات خارجية ومنظم فولتية.

Introduction

The ATmega microcontroller stands out as a preferred choice for industrial applications, offering features tailored for control systems, sensors, and broader industrial automation (Ammari et al., 2015; Weimer *et al.*, 2020). Its substantial memory, robust processing capabilities, and integrated peripherals cater to diverse needs. Expressive cases highlight its potential, such as managing complex dynamical systems (Kunikowski *et al.*, 2015) and merging PLCs for enhanced flexibility and security in traffic control (Kalle *et al.*, 2019). In smart home automation and agriculture, a dual-pronged approach combines microcontrollers for interior appliances with PLCs for outdoor equipment, capitalizing on robustness (Hanif *et al.*, 2019). In the power industry, the ATmega161 controls an innovative Uninterruptible Power Supply system, providing real-time updates and internet query responses (Navarro *et al.*, 2010; Udgata *et al.*, 2021). In industrial automation, the ATmega128 commands a powder packing machine, ensuring precision and efficiency (Kunikowski et al., 2015). Examples also span wireless home appliance management (Aliyu *et al.*, 2017; Ramani *et al.*, 2013), Pulse Electric Field pasteurization (Ananth, 2017; Stryczewska, 2020), underwater robotics, and UAV control (Nautiyal & Mehta, 2015; Stryczewska, 2020; Venkatesh et al., 2013). These applications showcase the versatility and innovative potential of ATmega microcontrollers in diverse industrial domains (Gupta *et al.*, 2021). The subsequent sections of this work will delve into the Kerduino board design, system design considerations, implementation, results, and analysis, concluding in section five.

The research focus centers on the convergence of electrical and mechanical considerations in system design, acknowledging the critical interplay between these two domains. Enhanced industrial boards based on ATmega microcontroller, which has the compatibility with Arduino board, results in number of platforms. namely, the M-DUINO58, Iono Uno, Controllino, Arduino Industrial 101, Industruino and Ruggeduino-ET. The boards utilize various connectivity mechanisms such as screw shields, pins, screwless terminals, and click-on mechanisms, all housed in protective casings. Programming is streamlined through the Arduino IDE. Power considerations vary, with some boards incorporating relays for increased output currents and others offering lower amperage levels. Notably, one board addresses the issue of rapid burning with power supplies exceeding 24 volts, as indicated in voltage regulator data sheets. Vibration's impact on sensor readings and microprocessor efficiency in industrial environments is inadequately addressed. The standardized process of downloading programs to microcontroller chips employs USB interfaces, but misalignments with IEC standards may necessitate additional supporting hardware, increasing costs.

Aim of the Work

The aim of this work is to develop an advanced open-source platform utilizing ATmega328p microcontrollers, tailored to address critical limitations within current industrial control solutions. The objective is to create a useful and efficient platform that overcomes challenges related to a number of issues, namely: power constraints, anti-vibration mechanisms, wiring, and sustainability.

Materials and Methods

Developing an industrial microcontroller platform involves a systematic and multidisciplinary approach to meet the robust requirements of industrial applications. The methodology outlined here is designed to address the unique challenges faced in industrial settings, emphasizing reliability, durability, and performance. Based on the gathered

requirements, design a robust system architecture that aligns with industrial standards. Consider factors such as scalability, modularity, and flexibility to accommodate diverse industrial applications. Define the core components, interfaces, and communication protocols that will form the foundation of the microcontroller platform. Figure 1 represent the methodology steps for Kerduino microcontroller design process. This platform aims to address various challenges prevalent in existing microcontroller platforms such as Arduino, Controllino, Iuno Uno, Industruino, Ruggeduino, and Arduino Industrial 101. The Kerduino prototype is designed to tackle issues in the realms of electrical performance, mechanical robustness, environmental resilience, and board programming interface.

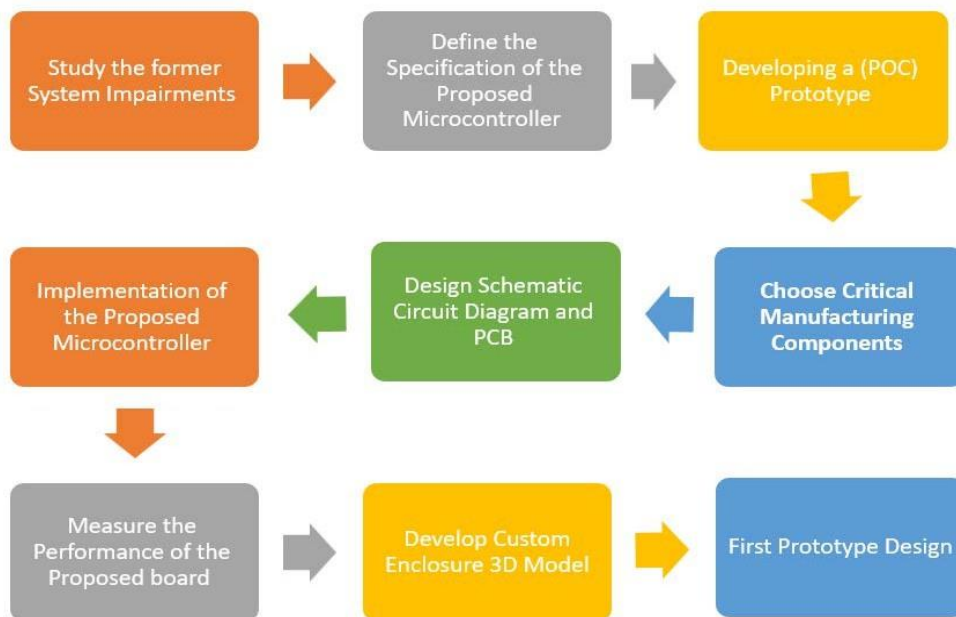

Figure (1) Methodology Steps for Kerduino Microcontroller Design.

Electrical Aspect

Focus on the electrical aspects of the platform, addressing challenges related to power distribution, signal integrity, and noise immunity. Choose components that adhere to industrial standards and have the necessary certifications. Implement redundancy and protection mechanisms to ensure the reliability of the electrical subsystems. DC power supply is designed to convert high-voltage AC mains electricity to a suitable low-voltage supply for electronic circuits and other devices (Olasunkanmi *et al.*, 2019). In this side, choosing the best regulator is main issue in electronic industries.

In microcontroller communication, two critical issues are amount of output power and voltage drops. Proper voltage regulation is key to addressing these concerns effectively (Watson *et al.*, 2016).

Electrical Power; the amount of available output power significantly impacts device and circuit performance, functionality, and user experience. Increasing available power can enhance system operation and overall capabilities.

Voltage Drops; voltage drops are common in electronic systems and occur when the supplied voltage decreases as it flows through a circuit. These drops can lead to irregular behavior, reduced efficiency, and component malfunction (Ibrahim, 2006). To address these issues, it's imperative to select a voltage regulator that can provide stable and reliable power to the system and could excels the regulator used in regular Arduino Uno which is SPX1117M3-L-5 voltage regulator (Luque Barrull, 2022).

Table (1) SPX1117M3-L-5 and LD1084V5 Regulator Specifications.

Parameter	SPX1117M3-L-5	LD1084V5
Vip	20V	30V
Vop	5V	5V
Vdrop	1.3V	1.5V@5A
Iop	0.8A	5A
PSRR	70dB/120Hz	72dB/120Hz
T	-40 °C to 125 °C	-40 °C to 125 °C

In other side the LD1084V5 voltage regulator's specifications (DigiKey, 2024) make it an excellent choice for powering microcontroller boards in industrial applications, offering reliable voltage regulation, high current capacity, noise rejection, and resilience across a range of operating temperatures as shown in Table 1 which shows the specifications of the both regulators and the difference in input voltage tolerance and voltage drop beside the output current (ALLDATASHEET.COM, 2024).

Mechanical Aspect

Design a sturdy and resilient mechanical framework that can withstand harsh industrial environments. Consider factors such as vibration resistance, shock tolerance, and the ability to operate in varying temperatures. Select materials and manufacturing processes that contribute to the overall mechanical robustness of the microcontroller platform.

Mechanism problems in Arduino refer to issues that can arise when building mechanical systems using an Arduino microcontroller (Wong *et al.*, 2019). These issues can range from problems with the physical construction of the mechanism to problems with the software that controls the mechanism.

Vibration Resistance; vibration is the study of oscillatory motions caused by

factors like mechanical stress. It can damage equipment and structures, affecting performance and safety. Vibration is measured with accelerometers and vibrometers, and analyzed using frequency analysis and Fourier transforms.

Vibration transmission can lead to issues like faulty connections, damaged components, or power supply problems in electronic packages. Selecting anti-vibration mounts requires considering factors like frequency, load capacity, environmental conditions, cost, maintenance, customization, and performance testing. Wiring Interface Mechanism; the wiring system is a versatile device for converting connections into connectors, enabling easy device and circuit wiring. It finds applications in various scenarios, with selection criteria including durability, safety, appearance, cost, accessibility, and maintenance. By converting connections to connectors, it simplifies device connections and disconnections with hands or basic tools. Common Wiring System applications include printed circuit boards (PCBs) and control cabinets, with PCB connectors offering advantages like compact design, multi-level connectors, innovative locking systems, versatile combination possibilities, and reliable panel feed-throughs (Frenzel, 2017).

In industrial connector units for programmable logic controllers (PLCs), terminal block conversion units include Push-in, Screw, Tension-spring, PCB, and Electrical/Electronic Cabinet components. Housings are used to protect electronic components in various environments.

Environmental Aspect

In the context of outdoor applications for microcontroller platforms, CASE (Casing, Assembly, and Sealing

Equipment) refers to specialized enclosures and protective systems designed to house microcontroller-based electronic systems and sensors in outdoor environments. These cases are crucial for ensuring the reliable and long-term operation of microcontroller platforms in harsh outdoor conditions.

To address challenges such as dust, humidity, temperature variations, and electromagnetic interference, the protective case developed for the Kerduino microcontroller board incorporates a unique and scientifically-informed design solution. The case features insulation properties to mitigate short circuit risks on conductive surfaces, adhering to safety standards. Panel mounts are prioritized over DIN rail mounts for superior stability in vibration-prone applications. Rubber/plastic washers strategically placed around screw terminal block modules and power jacks enhance environmental resistance. The ventilation design, featuring rectangular holes and spongy filters, efficiently dissipates heat while acting as a barrier against pollutants and humidity.

Board Programming Interface

In microcontroller communication, the interface between personal computers (PCs) and microcontrollers is crucial, typically over USB connections (Dukish, 2018). The ATmega328 microcontroller only supports TTL serial communication (Chintapalli, 2017). An intermediary module is needed to convert TTL signals into USB data, creating a virtual COM port on the PC. Additionally, programming or providing ICSP pins for loading code onto the microcontroller and RESET pin access is essential.

ATmega328 lacks native USB support, so an external USB to Serial Converter chip, like the FT232, is

needed to enable USB communication (Boyer *et al.*, 2017).

For programming and configuring AVR microcontrollers, the STK500 programmer is a practical choice. It's a versatile starter kit and development system designed for AVR Flash microcontrollers from Atmel Corporation. It communicates with a PC via USB, compatible with various ATMEL AVR microcontroller variants and popular development environments like AVR Studio and WINAVR(GCC).

System Design Implementation

The Kerduino microcontroller framework is a versatile system comprising essential components like the ATmega 328P processor, LD1085 Voltage Regulator, resistors, and capacitors. It features an ICSP Interface for programming, a 16k Crystal for precise timing, LEDs for feedback, and a Screw Shield for simplified connections. The framework allows

easy integration of additional components, making it suitable for a variety of projects and accessible to users of all skill levels. Kerduino provides a solid foundation for microcontroller-based innovations.

In the subsections that follow, we'll discuss the schematic design, PCB design, system programming, and case printing, taking us step by step toward the final implementation of the proposed prototype.

Schematic Design

The initial prototype was created using Fritzing version 9.4, featuring a straightforward microcontroller board design. The layout was constructed by interconnecting components according to the datasheets of the three key chips: ATmega328p microcontroller, ICSP, and voltage regulator. The breadboard connection is depicted in Figure 2.

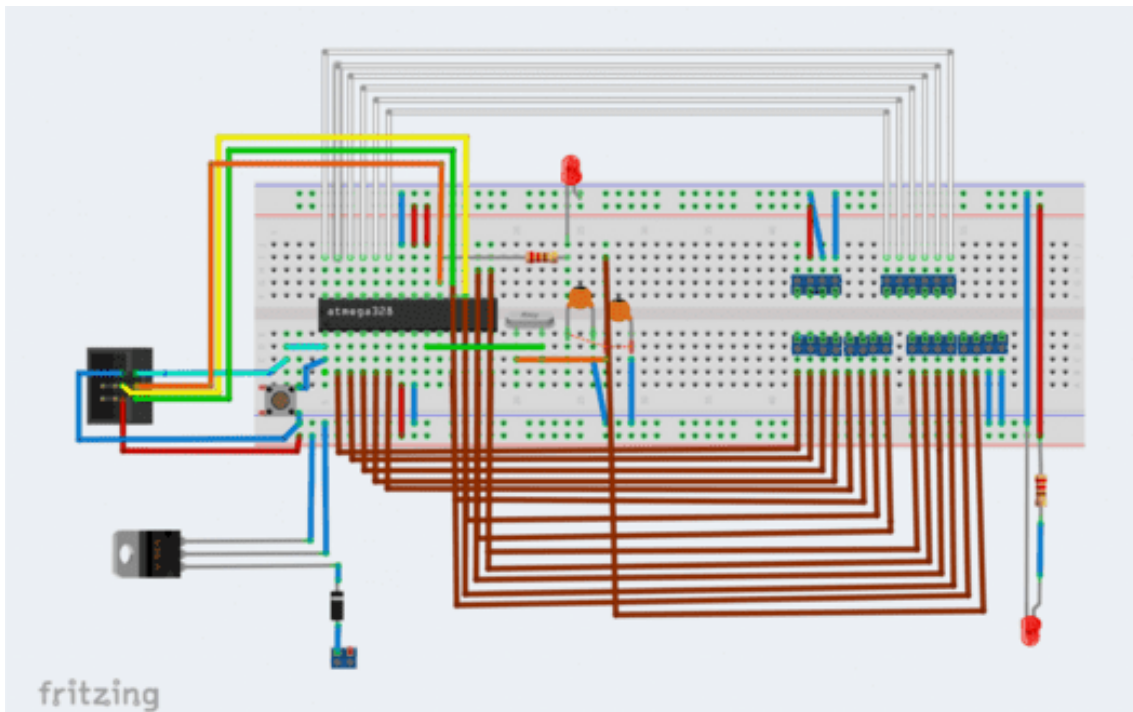

Figure (2) Breadboard Connection.

Figure 3 presents a schematic representation of the proposed microcontroller system, offering an in-depth view of its fundamental components and circuits. Each element plays a pivotal role in the system's functionality.

Figure 3 serves as a valuable resource for circuit design and troubleshooting, ensuring all components cooperate seamlessly to achieve the desired functionality and performance.

PCB Design

This section delves into the design of printed circuit boards (PCBs), specifically focusing on two critical aspects: power lines and PCB grounding.

PCB power lines play a critical role in

distributing electrical power from a voltage regulator to various components on the board. These lines are meticulously designed to meet specific application needs, considering factors like voltage drop, current-carrying capacity, and heat dissipation. Thicker power lines are employed for applications demanding high currents, offering lower resistance and efficient current carrying without overheating or voltage drops. Conversely, thinner lines are optimized for lower currents, conserving resources and space for low-power components. PCB grounding, achieved through the "common ground plane" method, ensures stable electrical connection

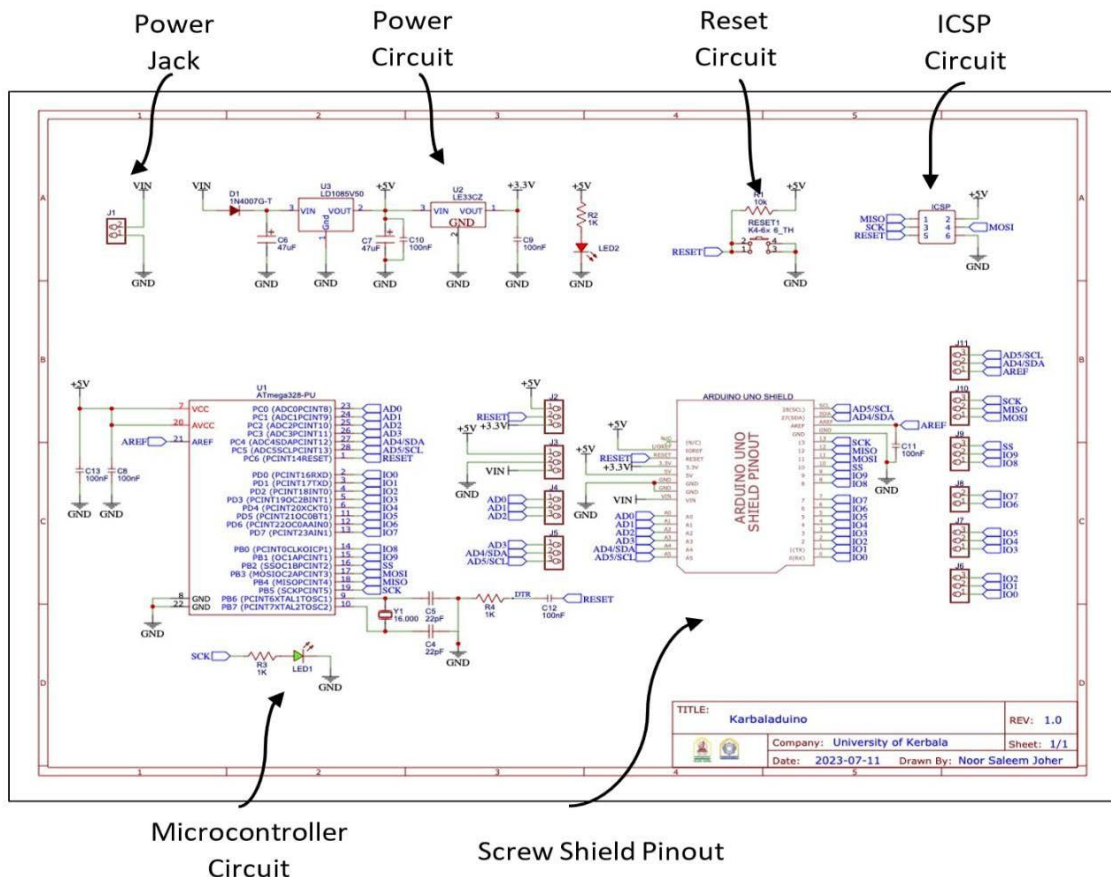

Figure (3) Schematic Design.

between various ground points on the board.

This approach simplifies connections, improves thermal characteristics, and reduces electromagnetic interference (EMI). Figure 4 visually illustrates the PCB design, showcasing the layout of power lines, ground planes, and components for a comprehensive understanding.

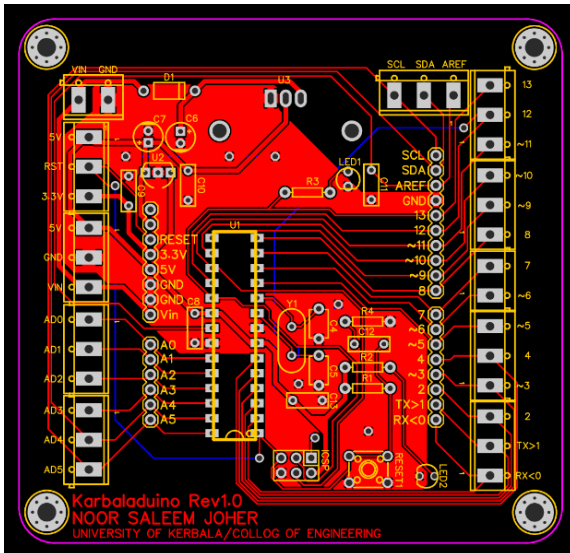

Figure (4) PCB Design

Innovative Protective Case for Kerduino Microcontroller Board

The case exhibits a two-piece injection-molded construction, enhancing durability and protective capabilities. Crafted from PLA+ material using Fusion360 3D design software, the case ensures durability, resistance to deformation, and customization tailored to the Kerduino microcontroller board's specifications. The 3D printing case design for Kerduino microcontroller is presenting in Figure 5.

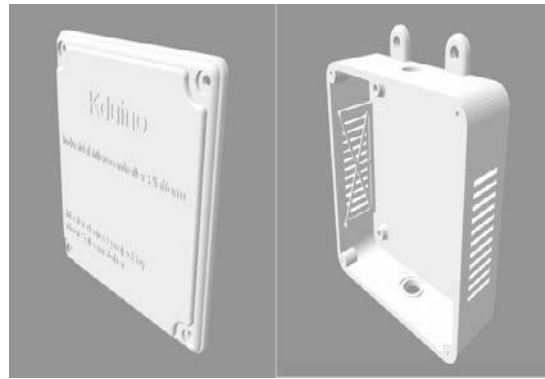

Figure (5) 3D Printing Case Design of Kerduino Microcontroller.

This scientifically-driven protective case provides a comprehensive solution that optimizes functionality, durability, and reliability for microcontroller-based projects.

Programming with STK500

Utilizing the STK500 programmer with ATmega microcontrollers offers advanced programming control, compatibility with various models, and flexibility across integrated development environments (IDEs) like AVR Studio or WINAVR(GCC), in addition to Arduino IDE. This external programmer provides advantages such as cost reduction, prevention of program tampering, increased memory space, and additional board space, eliminating the need for bootloader dependency. When paired with the Arduino IDE, the STK500 ensures robust and customized programming, streamlining development, offering debugging capabilities, and providing low-level access, essential for diverse hardware projects. The programming process involves burning the bootloader, selecting the port and board, configuring the programmer, and uploading with the programmer using specific commands within the Arduino IDE. These steps ensure seamless integration, confirming successful execution with the message "Done uploading" in the status bar.

Kerduino Prototype

The hardware implementation of the Kerduino prototype involves integrating a 28-pin ATmega328P microcontroller with a meticulously designed power supply. The power supply includes a diode for input protection, filtration for a stable 5-volt output, and strategically placed capacitors to smooth the current and prevent it from exceeding 3 amperes. A 16-megahertz crystal oscillator supports real-time processing, and three 1-kilohm resistors contribute to circuit protection. The board features a restart button and two LEDs: a red LED indicates power reception, and a green LED mirrors the functionality of an Arduino board for basic functionality verification. The development process included iterations with a breadboard for simulation, component selection through research and global market sourcing, and building the prototype on a zero PCB board. The PCB creation involved phases such as using a copper-clad laminate sheet with UV-curing paint solder mask, local execution with an FR-4 material and CNC machine, and the final phase of professional manufacturing outsourced to a Chinese workshop, ensuring efficient paints, superior materials, and precise

connection lines (as depicted in Figure 6).

Results and Discussion

The main results of the proposed microcontroller will be presenting as following:

Device Power

A crucial side of our examination centers on the LD1084V5 regulator's ability to manage an output power of up to 25W, which is higher than the one used in regular Arduino boards (i.e., SPX1117M3-L-5), which is limited to 4W.

The following formula was used to calculate the wattage.

$$\text{Electrical Power (Watts)} = \text{Voltage} \times \text{Current} \times \text{Power Factor (pf)}$$

with the power factor being equal to unity (pf = 1). The difference of powers and Amperes use shown in Figure 6.

Considering the voltage drop, in the case of the Arduino, there is a voltage drop of 1.3 volts when drawing a current of 0.8A.

However, in our prototype, voltage drop at the same current is 0.24 volts only. However, according to LD1084V5 datasheet, at maximum current (i.e., 5A) the voltage drop is 1.5 volts only.

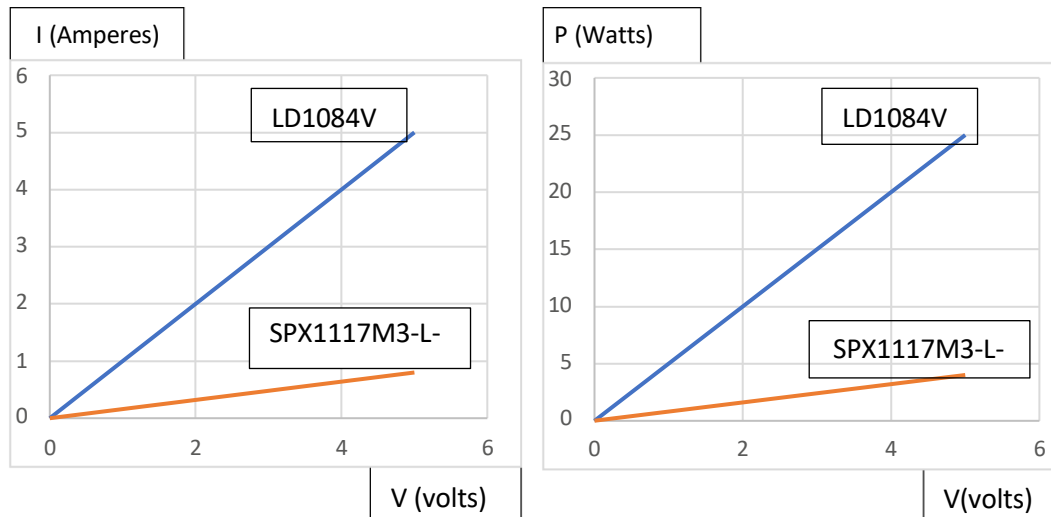

Figure (6) Difference of powers and Amperes between LD1084V5 and SPX1117M3-L-5.



Figure (7) Final Prototype for Kerduino

In terms of voltage tolerance, we also achieve a better solution. More specifically, most of the platforms that considered in the literature of this thesis, broke down at voltage exceeds 20V.

The Kerduino voltage tolerance reaches until 30V without any damage or burning in regulator or other chips as tested by applying input voltage more than 28 volts, which gives it the advantage over the most boards mentioned in the literature.

Note that the output power of the Kerduino is relay driven output, i.e., it is not the power provided by the board circuit but by a relay derived by the board. While in the Kerduino case, it is the power provided by the board itself.

Mechanical Evaluation of Kerduino Microcontroller

The mechanical evaluation of the Kerduino microcontroller is crucial for assessing its operational performance and durability. It comprises two key dimensions: System Wiring Evaluation and Anti-Vibration Mechanism.

a) System Wiring Evaluation

This dimension focuses on meticulous wiring inspection, essential for seamless microcontroller integration. Screw shield terminals are preferred by engineers for their robustness, simplicity, and compatibility with various wire sizes. These versatile, durable, and cost-effective terminals facilitate easy maintenance and adjustments, meeting engineering demands.

In lab tests, the Kerduino microcontroller outperformed its predecessor, demonstrating steady performance under conditions of vibration and power load stress. In contrast, the old microcontroller exhibited vulnerabilities, leading to degraded performance and unreliable outputs. This showcases Kerduino's

adaptability to challenging environments.

Figure 8 provides evidence of the effectiveness of using screw shield terminals to strengthen wiring robustness. In various experiments involving an LCD with 12 wires, such as testing vibration, temperature, and humidity, the Kerduino microcontroller consistently displayed accurate readings on the LCD screen with no errors, leaks, or missing connections.



Figure (8) Testing Wiring Mechanism strength.

b) Anti-Vibration Mechanism

In the industrial microcontroller field, achieving optimal solutions involves integrating various anti-vibration systems. This approach has rubber mounts for high-frequency vibrations effectively isolating vibrations. This modification optimizes vibration mitigation for specific industrial microcontroller platforms.

Comparing the proposed microcontroller with its predecessors reveals a significant difference. Former models lacked anti-vibration mounts, necessitating a detailed evaluation and selection of suitable mounts based on size and effectiveness.

The proposed microcontroller excels in maintaining wiring integrity even under shock and vibration, showcasing its robust design. In contrast, the older microcontroller's performance and

wiring system cannot withstand vibration conditions.

Table (2) Outputs of vibration sensor.

Status	Arduino	Kerduino
Status1	6.6 rms	1.37 rms
Status2	8.93 rms	2.72 rms
Status3	12.81 rms	2.9 rms
Status4	14.12 rms	2.9 rms
Status5	17.75 rms	3.86 rms

In the experiment, a Strong Vibration Motor with EVC Material 3-6V DC with frequency reaches to 200 Hz is used with vibration Meter (Fluke 805) to read the effect of vibration, with different statuses by increasing the velocity of motor. First status at the lower value of velocity, the root mean square (RMS) of vibration in (mm/s) measurements was 1.37 on Kerduino, while it reaches 6.6 on Arduino as shown in Table 1. The five statuses of experiment show the effectiveness of using the rubber mounts in decreasing vibration effect and the difference became obvious in Figure 9. During the experiment, one of the wires on Arduino board went out of the pin due to vibration effect. This aspect emphasizes the importance of anti-vibration mechanism as well as the screw shield robustness in industrial microcontroller platforms and highlights the exceptional ability of the proposed microcontroller to maintain operational integrity under adverse vibrational conditions.

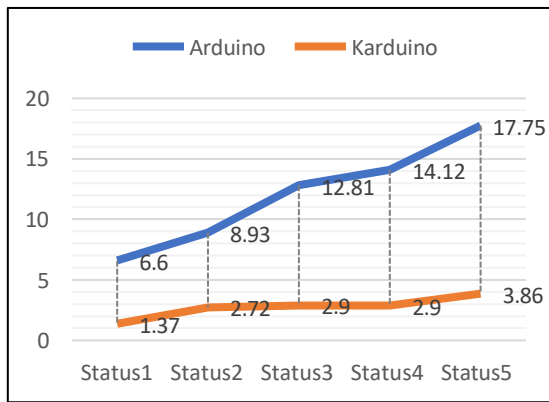

Figure (9) Vibration meter readings of Kerduino and Arduino.

c) Environmental Durability

For industrial applications, a device must exhibit consistent reliability over a broad temperature range. This typically involves soldering components onto the circuit board and using protective casings or racks, along with redundancy measures like multiple power supply options. In a side-by-side comparison, the proposed microcontroller surpasses its predecessor. The former microcontroller struggles in harsh environments without a protective enclosure, whereas the proposed one, explicitly designed for industrial settings, remains robust. In the experiment ran out, two sensor DHT22 used with LCD to compare the humidity inside Kerduino box, with it is environment, outside box. At the beginning they were at the same degree almost, after that when a source of moisture is exposed, the differences show up as in Table 3.

Table (3) Humidity Comparison between Inside Box and Outside.

Time	H (out box)	H (in box)
0 min	58%	56%
10 min	70.4%	62%
20 min	87%	66.6%
30 min	91.5%	73%
40 min	97.6%	80.6%

Notably, the proposed microcontroller not only maintains its operational

capabilities but excels in challenging conditions. In contrast, the former microcontroller experiences performance degradation and board damage when left unprotected, rendering it susceptible to dust, temperature fluctuations, and humidity. This assessment underscores the significance of a robust design, protective measures, and resilient components for microcontrollers in demanding industrial environments, confirming the suitability of the proposed microcontroller for such conditions.

Kerduino Benefits and contributions

The Kerduino microcontroller excels in industrial applications, offering several key advantages, including:

- 1. Wide Voltage Tolerance:** It operates efficiently within a versatile voltage range of 12-30 V, accommodating diverse industrial power supplies.
- 2. High Power Output:** With a remarkable 5A current capacity (25W), it drives demanding industrial equipment.
- 3. Durability in Harsh Environments:** Engineered to withstand tough conditions, including temperature fluctuations, vibration, dust, and humidity.
- 4. Compatibility and Customization:** It seamlessly works with various sensors, actuators, and shields, allowing customization for specific industrial needs.
- 5. Open Source:** Its open-source nature fosters collaboration, transparency, and user access to design, code, and documentation. All the sources and design files for the project can be found in the GitHub repository at the link: <https://github.com/NoorJoher/Kerduino>

These attributes collectively establish the Kerduino as a versatile, reliable, and resilient choice for industrial microcontroller applications.

Conclusions

In conclusion, the development of the Kerduino industrial microcontroller platform represents a pinnacle in efficient and systematic design methodology, emphasizing optimization and accelerated development. Studying former system impairments, defining precise specifications, and constructing a proof-of-concept prototype form a cohesive strategy that minimizes trial and error, thereby expediting time-to-market. The infusion of professional expertise ensures a continuous refinement of the design.

The Kerduino microcontroller's distinct advantages lie in its robust system design, incorporating advanced electrical concepts such as effective power regulation and voltage regulators using LD1084V5. Its mechanical resilience, demonstrated through meticulous system wiring and anti-vibration mechanisms utilizing screw shield terminals and rubber mounts, contributes to superior performance. The incorporation of a protective case, designed with Fusion360 3D software, adds insulation, efficient ventilation, and durability, further fortifying its suitability for demanding outdoor environments.

Comparative analysis highlights the Kerduino microcontroller's wide voltage tolerance and exceptional resilience in challenging conditions, positioning it as a standout choice. Its versatility, high power output (25W) without relay using, and durability in harsh environments set it apart from other designs. The Kerduino platform emerges as an innovative and reliable solution, offering a holistic package of

advanced features that address the evolving demands of industrial microcontroller technologies

References

aliyu, S.; Yusuf, A.; Abdullahi, U.; & Hafiz, M. (2017). Development of A Low-Cost Gsm-Bluetooth Home Automation System.

Alldatasheet.Com. (2024). "Electronic Components Datasheet Search." <https://www.alldatasheet.com/view.jsp?Searchword=Ld1084v5&Sfield=2>

Ammari, H. M.; Gomes, N.; Jacques, M.; Maxim, B.; & Yoon, D. (2015). A Survey of Sensor Network Applications and Architectural Components. *Adhoc & Sensor Wireless Networks*, 25.

Ananth, C. (2017). Cardiac Patients Monitoring at A Distance. Anchor Academic Publishing.

Boyer, K.; Brubaker, L.; Everly, K.; Herriman, R.; Houston, P.; Ruckle, S.; Scobie, R.; & Ulanday, I. (2017). A Distributed Sensor Network for An Off-Road Racing Vehicle.

Chintapalli, S. (2017). Communication Protocols on the Pic24ep and Arduino- A Tutorial for Undergraduate Students.

Digikey. (2024). Spx1117m3-L-5-0/Tr. <https://www.digikey.com/en/products/detail/maxlinear-inc/spx1117m3-l-5-0-tr/2472292>

Dukish, B. (2018). Coding the Arduino: Building Fun Programs, Games, and Electronic Projects. Apress.

Frenzel, L. E. (2017). Electronics Explained: Fundamentals for Engineers, Technicians, and Makers. Newnes.

Gupta, S.; Kohli, M.; Kumar, R.; & Bandral, S. (2021). Iot Based Underwater Robot for Water Quality

Monitoring. Iop Conference Series: Materials Science and Engineering,

Hanif, M.; Mohammad, N.; & Harun, B. (2019). An Effective Combination of Microcontroller and Plc for Home Automation System. 2019 1st International Conference on Advances In Science, Engineering and Robotics Technology (Icasert).

Ibrahim, D. (2006). Microcontroller Based Applied Digital Control. John Wiley.

Kalle, S.; Ameen, N.; Yoo, H.; & Ahmed, I. (2019). Klik on Plcs! Attacking Control Logic with Decompilation and Virtual Plc. Binary Analysis Research (Bar) Workshop, Network and Distributed System Security Symposium (Ndss).

Kunikowski, W.; Czerwiński, E.; Olejnik, P.; & Awrejcewicz, J. (2015). An Overview of Atmega Avr Microcontrollers Used in Scientific Research and Industrial Applications. *Pomiary Automatyka Robotyka*, 19(1), 15-19.

Luque Barrull, J. (2022). Disseny, Fabricació I Muntatge D'un Braç Robòtic De 4 Graus De Llibertat.

Nautiyal, S.; & Mehta, A. (2015). Autonomous Underwater Surveillance Robot. In *Journal of Electronics and Communication Engineering* (Vol. 10, Pp. 53-61).

Navarro, K. F.; Lawrence, E.; Hoang, D.; & Lim, Y. Y. (2010). A Distributed Network Management Approach to Wsn in Personal Healthcare Applications. *International Journal on Advances in Networks and Services* Volume 3, Number 1 & 2, 2010.

Olasunkanmi, O. G.; Olajide, M.; Alao, P.; & Jagun, Z. (2019). Design

and Development of Microcontroller-Based Ac Mains Monitor Circuit. *Applied Journal of Environmental Engineering Science*, 5(4), 5-4 (2019) 2370-2383.

Ramani, R.; Valarmathy, S.; Suthanthiravanitha, N.; Selvaraju, S.; Thirupathi, M.; & Thangam, R. (2013). Vehicle Tracking And Locking System Based on Gsm and Gps. *Ij Intelligent Systems And Applications*, 9, 86-93.

Stryczewska, H. D. (2020). Supply Systems of Non-Thermal Plasma Reactors. Construction Review with Examples of Applications. *Applied Sciences*, 10(9), 3242.

Udgata, S. K.; Suryadevara, N. K.; Udgata, S. K.; & Suryadevara, N. K. (2021). Advances in Sensor Technology and Iot Framework to Mitigate Covid-19 Challenges. *Internet of Things and Sensor Network for Covid-19*, 55-82.

Venkatesh, C.; Sekhar, C. C.; Venugopal, M.; & Kumar, M. P. (2013). A Robotic Colonizer System for Identifying and Estimation of Marine Habitats in Aqueous Environment. 2013 International Conference on Optical Imaging Sensor and Security (Icoss).

Watson, J. D.; Watson, N. R.; & Das, B. (2016). Effectiveness of Power Electronic Voltage Regulators in The Distribution Network. *Iet Generation, Transmission & Distribution*, 10(15), 3816-3823.

Weimer, A.; Kohlstedt, M.; Volke, D. C.; Nickel, P. I.; & Wittmann, C. (2020). Industrial Biotechnology of *Pseudomonas Putida*: Advances and Prospects. *Applied Microbiology and Biotechnology*, 104, 7745-7766.

Wong, K. K.; Samah, N. A. A.; Sahimi, M. S.; & Othman, W. (2019). Development of Reverse Vending

Machine Using Recycled Materials and Arduino Microcontroller. International Journal of Engineering Creativity and Innovation, 1(1), 7-16.